

***ARMY TM 9-6115-673-13&P AIR FORCE TO 35C2-3-512-1**

TECHNICAL MANUAL

**OPERATOR AND FIELD MAINTENANCE MANUAL
(INCLUDING REPAIR PARTS AND SPECIAL TOOLS LIST)**

FOR

2 kW MILITARY TACTICAL GENERATOR SETS

120 VAC, 60 Hz

MEP-531A (DEWEY)

(NSN: 6115-01-435-1565) (EIC: GE2)

120 VAC, 60 Hz

MECHRON

(NSN: 6115-21-912-0393) (EIC: VIB)

28 VDC

MEP-501A (DEWEY)

(NSN: 6115-01-435-1567) (EIC: LTJ)

28 VDC

MECHRON

(NSN: 6115-21-912-0392) (EIC: VBD)

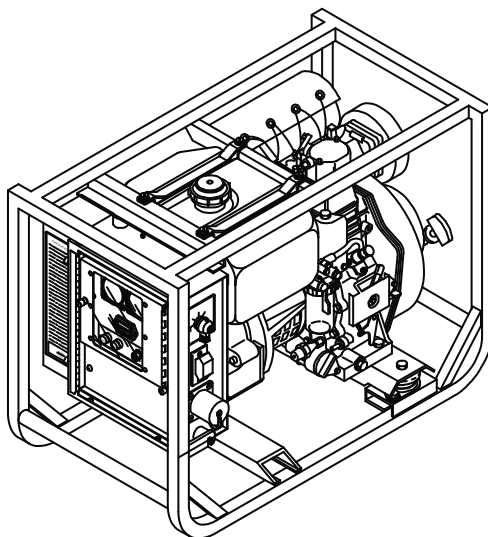

***SUPERSEDURE NOTICE** - This manual supersedes TM 9-6115-673-13&P, AND TO 35C2-3-512-1, dated 15 September 2002. Date of issue for the revised manual is: 30 June 2010.

DISTRIBUTION STATEMENT A - Approved for public release; distribution is unlimited.

HEADQUARTERS, DEPARTMENTS OF THE ARMY AND AIR FORCE

30 JUNE 2010

WARNING SUMMARY

FIRST AID

For First Aid information, refer to FM 4-25.11.



5

5 SAFETY STEPS TO FOLLOW IF SOMEONE IS THE VICTIM OF ELECTRICAL SHOCK

1

DO NOT TRY TO PULL OR GRAB THE INDIVIDUAL

2

IF POSSIBLE, TURN OFF THE ELECTRICAL POWER

3

IF YOU CANNOT TURN OFF THE ELECTRICAL POWER, PULL, PUSH OR LIFT THE PERSON TO SAFETY USING A DRY WOODEN POLE OR A DRY ROPE OR SOME OTHER INSULATING MATERIAL

4

SEND FOR HELP AS SOON AS POSSIBLE

5

AFTER THE INJURED PERSON IS FREE OF CONTACT WITH THE SOURCE OF ELECTRICAL SHOCK, MOVE THE PERSON A SHORT DISTANCE AWAY AND IMMEDIATELY START ARTIFICIAL RESUSCITATION

WARNING SUMMARY - Continued

WARNING AND CAUTION STATEMENTS

Warning and Caution statements have been strategically placed throughout this text prior to operating procedures, practices, or conditions considered essential to the protection of personnel (WARNING) or equipment and property (CAUTION).

A WARNING or CAUTION will apply each time the related step is repeated. Prior to starting any task the WARNINGS or CAUTIONS included in the text for that task must be reviewed and understood. Refer to the materials list at the beginning of the appropriate manual section for materials used during maintenance of this equipment. This warning summary contains the WARNINGS and CAUTIONS included in the manual. The detailed warnings for hazardous materials only are listed separately in the warning summary as the "Hazardous Materials Warnings" section.

WARNING

High voltage is produced when this generator set is in operation. Use care when working around an open control panel with the generator set operating. Improper operation and/or failure to follow this warning could result in personal injury or death by electrocution.

WARNING

Never attempt to start the generator set if it is not properly grounded. Failure to observe this warning could result in serious injury or death by electrocution.

WARNING

Never attempt to connect or disconnect load cables while the generator set is running. Failure to observe this warning could result in severe personal injury or death by electrocution.

WARNING

If 24 VDC battery source is connected to the North Atlantic Treaty Organization (NATO) slave receptacle, DC voltages are present at generator set electrical components even with generator set shut down. Avoid grounding self when touching any electrical components. Failure to observe this warning can result in personal injury.

WARNING

The fuels in this generator set are flammable. Do not smoke or use open flames when performing maintenance. Do not service or drain the fuel system while open flames are present. Flames and explosion could result in severe personal injury or death. Use a container or cloth to catch any excess fuel to prevent spilling over engine components. Be sure to properly dispose of diesel fuel and diesel fuel soaked cloths.

WARNING

Hot fueling of generator sets while they are operating presents a safety hazard and should not be attempted. Hot engine surfaces and sparks produced from the engine and generator circuitry are possible sources of ignition. Failure to observe this warning could result in severe personal injury or death.

WARNING

Exhaust discharge contains deadly gases. Do not operate generator set in enclosed area unless exhaust discharge is properly vented outside. Position as far away from personnel, shelters, and occupied vehicles as possible. Failure to observe this warning could result in severe personal injury or death due to carbon monoxide poisoning.

WARNING

High fuel pressure is generated as a result of operation of the generator set. High-pressure leaks could cause severe personal injury or death.

WARNING SUMMARY - Continued

WARNING

Avoid contacting metal items with bare skin in extreme cold weather. Failure to observe this warning can result in personal injury.

WARNING

Remove metal jewelry when working on electrical system/components. Failure to observe this warning could cause severe personnel injury from electric shock.

WARNING

The noise level of this generator set when operating could cause hearing damage. Hearing protective devices must be worn when operating or working within 13 feet of the generator set when it is running. Failure to observe this warning can result in personal injury.

WARNING

Cleaning solvents are flammable and toxic to eyes, skin, and respiratory tract. Skin/eye protection required. Avoid repeated/prolonged contact. Good general ventilation is normally adequate.

WARNING

When using compressed air, wear protective glasses and use clean, low-pressure air, 30 psi (206.8 kPa) maximum. Failure to follow these instructions could result in eye injury.

WARNING

Chemical Agent Resistant Coating (CARC) paint dust is a health hazard. Wear protective eyewear, mask, and gloves when sanding CARC painted surfaces. Failure to comply can cause personal injury.

WARNING

Adhesive is flammable and toxic. Vapors may ignite explosively. Avoid breathing in vapors. Provide adequate ventilation to prevent vapor concentrations in excess of permissible exposure levels. Keep away from heat, sparks, and open flame. Do not smoke. Extinguish all flames and turn off non-explosion-proof electrical equipment during use until vapors are dissipated. Close container tightly after use. Contains Methylethketone. Avoid swallowing.

WARNING

Be sure the load terminal retaining clip is closed to prevent contact with the lug cover as electrical shock could occur.

WARNING

Note the orientation of the load terminals before removing them. They must be installed in exactly the same way to preclude the possibility of accidental contact with the lug cover and the potential for electrical shock resulting from this contact.

WARNING

MEP-531A engine/alternator assembly weighs 100 lbs (45.4 kg). MEP-501A engine/alternator assembly weighs 80 lbs (36.2 kg). Use caution when removing assembly to prevent personal injury.

LIST OF EFFECTIVE PAGES / WORK PACKAGES

NOTE: This manual supersedes TM 9-6115-673-13&P, AND TO 35C2-3-512-1, dated 15 September 2002. Zero in the "Change No." column indicates an original page or work package.

Date of issue for the original manual is:

Original 30 JUNE 2010

TOTAL NUMBER OF PAGES FOR FRONT AND REAR MATTER IS 34 AND TOTAL NUMBER OF WORK PACKAGES IS 165, CONSISTING OF THE FOLLOWING:

Page / WP No.	Change No.	Page / WP No.	Change No.
Front Cover	0	WP 0025 (2 pgs)	0
Blank	0	WP 0026 (2 pgs)	0
Warning summary (4 pgs)	0	WP 0027 (4 pgs)	0
i - xxvii	0	WP 0028 (2 pgs)	0
xxviii-Blank	0	WP 0029 (4 pgs)	0
Chp 1 title page	0	WP 0030 (2 pgs)	0
Chp 1 Index	0	WP 0031 (4 pgs)	0
WP 0001 (4 pgs)	0	WP 0032 (4 pgs)	0
WP 0002 (6 pgs)	0	WP 0033 (2 pgs)	0
WP 0003 (14 pgs)	0	WP 0034 (2 pgs)	0
Chp 2 title page	0	WP 0035 (4 pgs)	0
Chp 2 Index	0	WP 0036 (2 pgs)	0
WP 0004 (6 pgs)	0	WP 0037 (4 pgs)	0
WP 0005 (14 pgs)	0	WP 0038 (4 pgs)	0
WP 0006 (4 pgs)	0	WP 0039 (2 pgs)	0
Chp 3 title page	0	WP 0040 (2 pgs)	0
Chp 3 Index	0	WP 0041 (4 pgs)	0
WP 0007 (2 pgs)	0	WP 0042 (2 pgs)	0
WP 0008 (8 pgs)	0	WP 0043 (2 pgs)	0
Chp 4 title page	0	WP 0044 (2 pgs)	0
Chp 4 Index	0	WP 0045 (2 pgs)	0
WP 0009 (4 pgs)	0	WP 0046 (2 pgs)	0
WP 0010 (6 pgs)	0	WP 0047 (2 pgs)	0
WP 0011 (2 pgs)	0	WP 0048 (2 pgs)	0
Chp 5 title page	0	WP 0049 (2 pgs)	0
Chp 5 Index	0	WP 0050 (4 pgs)	0
WP 0012 (2 pgs)	0	WP 0051 (2 pgs)	0
WP 0013 (30 pgs)	0	WP 0052 (2 pgs)	0
Chp 6 title page	0	WP 0053 (4 pgs)	0
Chp 6 Index	0	WP 0054 (2 pgs)	0
WP 0014 (4 pgs)	0	WP 0055 (4 pgs)	0
WP 0015 (4 pgs)	0	WP 0056 (4 pgs)	0
WP 0016 (4 pgs)	0	WP 0057 (2 pgs)	0
WP 0017 (2 pgs)	0	WP 0058 (2 pgs)	0
WP 0018 (2 pgs)	0	WP 0059 (4 pgs)	0
WP 0019 (2 pgs)	0	WP 0060 (2 pgs)	0
WP 0020 (2 pgs)	0	WP 0061 (4 pgs)	0
WP 0021 (2 pgs)	0	WP 0062 (4 pgs)	0
WP 0022 (2 pgs)	0	WP 0063 (4 pgs)	0
WP 0023 (2 pgs)	0	WP 0064 (4 pgs)	0
WP 0024 (2 pgs)	0		

LIST OF EFFECTIVE PAGES / WORK PACKAGES - CONTINUED

Page / WP No.	Change No.	Page / WP No.	Change No.
WP 0065 (2 pgs)	0	WP 0114 (2 pgs)	0
WP 0066 (2 pgs)	0	WP 0115 (2 pgs)	0
WP 0067 (4 pgs)	0	Chp 7 title page	0
WP 0068 (2 pgs)	0	Chp 7 Index	0
WP 0069 (2 pgs)	0	WP 0116 (6 pgs)	0
WP 0070 (4 pgs)	0	WP 0117 (4 pgs)	0
WP 0071 (4 pgs)	0	WP 0118 (4 pgs)	0
WP 0072 (2 pgs)	0	WP 0119 (4 pgs)	0
WP 0073 (2 pgs)	0	WP 0120 (4 pgs)	0
WP 0074 (4 pgs)	0	WP 0121 (4 pgs)	0
WP 0075 (4 pgs)	0	WP 0122 (4 pgs)	0
WP 0076 (2 pgs)	0	WP 0123 (4 pgs)	0
WP 0077 (2 pgs)	0	WP 0124 (4 pgs)	0
WP 0078 (4 pgs)	0	WP 0125 (4 pgs)	0
WP 0079 (2 pgs)	0	WP 0126 (4 pgs)	0
WP 0080 (2 pgs)	0	WP 0127 (4 pgs)	0
WP 0081 (2 pgs)	0	WP 0128 (4 pgs)	0
WP 0082 (4 pgs)	0	WP 0129 (4 pgs)	0
WP 0083 (4 pgs)	0	WP 0130 (4 pgs)	0
WP 0084 (6 pgs)	0	WP 0131 (4 pgs)	0
WP 0085 (4 pgs)	0	WP 0132 (4 pgs)	0
WP 0086 (2 pgs)	0	WP 0133 (4 pgs)	0
WP 0087 (2 pgs)	0	WP 0134 (4 pgs)	0
WP 0088 (4 pgs)	0	WP 0135 (4 pgs)	0
WP 0089 (6 pgs)	0	WP 0136 (4 pgs)	0
WP 0090 (2 pgs)	0	WP 0137 (8 pgs)	0
WP 0091 (8 pgs)	0	WP 0138 (6 pgs)	0
WP 0092 (2 pgs)	0	WP 0139 (4 pgs)	0
WP 0093 (4 pgs)	0	WP 0140 (4 pgs)	0
WP 0094 (4 pgs)	0	WP 0141 (4 pgs)	0
WP 0095 (4 pgs)	0	WP 0142 (4 pgs)	0
WP 0096 (8 pgs)	0	WP 0143 (4 pgs)	0
WP 0097 (4 pgs)	0	WP 0144 (4 pgs)	0
WP 0098 (2 pgs)	0	WP 0145 (10 pgs)	0
WP 0099 (2 pgs)	0	WP 0146 (10 pgs)	0
WP 0100 (2 pgs)	0	WP 0147 (4 pgs)	0
WP 0101 (2 pgs)	0	WP 0148 (4 pgs)	0
WP 0102 (2 pgs)	0	WP 0149 (4 pgs)	0
WP 0103 (2 pgs)	0	WP 0150 (4 pgs)	0
WP 0104 (2 pgs)	0	WP 0151 (4 pgs)	0
WP 0105 (2 pgs)	0	WP 0152 (4 pgs)	0
WP 0106 (2 pgs)	0	WP 0153 (2 pgs)	0
WP 0107 (2 pgs)	0	WP 0154 (4 pgs)	0
WP 0108 (4 pgs)	0	WP 0155 (6 pgs)	0
WP 0109 (2 pgs)	0	WP 0156 (12 pgs)	0
WP 0110 (2 pgs)	0	Chp 8 title page	0
WP 0111 (2 pgs)	0	Chp 8 Index	0
WP 0112 (2 pgs)	0	WP 0157 (2 pgs)	0
WP 0113 (2 pgs)	0	WP 0158 (4 pgs)	0

LIST OF EFFECTIVE PAGES / WORK PACKAGES - CONTINUED

Page / WP No.	Change No.	Page / WP No.	Change No.
WP 0159 (6 pgs)	0		
WP 0160 (4 pgs)	0		
WP 0161 (2 pgs)	0		
WP 0162 (2 pgs)	0		
WP 0163 (2 pgs)	0		
WP 0164 (4 pgs)	0		
WP 0165 (12 pgs)	0		
INDEX-1 - INDEX-6	0		
FP-1	0		
FP-2 Blank	0		
FP-3	0		
FP-4 Blank	0		
FP-5	0		
FP-6 Blank	0		
FP-7	0		
FP-8 Blank	0		
FP-9	0		
FP-10 Blank	0		
FP-11	0		
FP-12 Blank	0		
Inside back cover	0		
Back cover	0		

**HEADQUARTERS
DEPARTMENTS OF THE ARMY AND AIR FORCE
WASHINGTON, D.C., 30 JUNE 2010**

**TECHNICAL MANUAL
OPERATOR AND FIELD MAINTENANCE MANUAL
(INCLUDING REPAIR PARTS AND SPECIAL TOOLS LIST)
FOR
2kW MILITARY TACTICAL GENERATOR SETS
120 VAC, 60 Hz,
MEP-531A (DEWEY)
(NSN: 6115-01-435-1565) (EIC:GE2)
120 VAC, 60 Hz,
MECHRON
(NSN: 6115-21-912-0393) (EIC:VIB)
28 VDC,
MEP-501A(DEWEY)
(NSN: 6115-01-435-1567) (EIC:LTJ)
28 VDC,
MECHRON
(NSN: 6115-21-912-0392) (EIC:VBD)**

REPORTING ERRORS AND RECOMMENDING IMPROVEMENTS

You can help improve this manual. If you find any mistakes or if you know of a way to improve the procedures, please let us know. Reports, as applicable by the requiring Service, should be submitted as follows:

- (a) (A) Army - Mail your letter or DA Form 2028 (Recommended Changes to Publications and Blank Forms) located in the back of this manual, directly to: Commander, U.S. Army CECOM Life Cycle Management Command (LCMC) Fort Monmouth, ATTN: AMSEL-LC-LEO-E-CM, Fort Monmouth, NJ 07703-5006. You may also send in your recommended changes via electronic mail or by fax. Our fax number is 732-532-1556, DSN 992-1556. Our e-mail address is MONM-AMSELLEOPUBSCHG@conus.army.mil. Our online web address for entering and submitting DA Form 2028 is <http://edm.monmouth.army.mil/pubs/2028.html>.
- (b) (F) Air Force - By Air Force AFTO Form 22 (Technical Manual (TM) Change Recommendation and Reply) in accordance with TO 00-5-1.
A reply will be furnished to you.

***SUPERSEDURE NOTICE** - This manual supersedes TM 9-6115-673-13&P, AND TO 35C2-3-512-1, dated 15 September 2002. Date of issue for the revised manual is: 30 June 2010.

DISTRIBUTION STATEMENT A - Approved for public release; distribution is unlimited.

TABLE OF CONTENTS

	Page No.
	<u>WP Sequence No.</u>
How to Use This Manual	
Chapter 1 - General Information, Equipment Description and Theory of Operation	
General Information	WP 0001
Type of Manual.....	0001-1
Table 1. Model Numbers and Equipment Names.....	0001-1
Purpose of Equipment.....	0001-1
Figure 1. Military Tactical Generator (MTG) Set - 2 kW	0001-2
Maintenance Forms, Records, and Reports.....	0001-3
Reporting Equipment Improvement Recommendation (EIR)	0001-3
Corrosion Prevention and Control (CPC)	0001-3
Destruction of Army Materiel to Prevent Enemy Use	0001-3
Preparation for Storage or Shipment.....	0001-3
Warranty Information	0001-3
List of Abbreviations/Acronyms	0001-4
Supporting Information for Repair Parts, Special Tools, TMDE and Support Equipment	0001-4
Equipment Description and Data	WP 0002
Equipment Description	0002-1
Figure 1. Location of Major Generator Set Components.....	0002-1
Equipment Differences	0002-2
Equipment Data.....	0002-3
Table 1. Leading Particulars.....	0002-3
Theory of Operation	WP 0003
Fuel System.....	0003-1
Figure 1. Generator Set Fuel System.....	0003-2
Engine Air Intake and Exhaust System	0003-2
Figure 2. Engine Air Intake and Exhaust System	0003-3
Speed Control System.....	0003-3
Figure 3. Diesel Engine Governor	0003-4
Diesel Engine Electrical Starting System	0003-5
Figure 4. Diesel Engine Electrical Starting System	0003-6
Generator Voltage Regulation and Output Supply (MEP-531A)	0003-6
Figure 5. Generator Voltage Regulation System (MEP-531A).....	0003-7
Figure 6. Generator Output Supply System (MEP-531A).....	0003-8
Generator Voltage Regulation and Output Supply (MEP-501A)	0003-8
Figure 7. Generator Voltage Regulation System (MEP-501A).....	0003-10
Figure 8. Generator Output Supply System (MEP-501A).....	0003-11
Generator Control Circuit.....	0003-11
Figure 9. Generator Control Circuit	0003-12
Low Oil Pressure Protection	0003-13
Figure 10. Low Engine Oil Pressure Protection System.....	0003-13
Chapter 2 - Operator Instructions	
Description and Use of Operator Controls and Indicators	WP 0004
Figure 1. Operator Controls and Indicators (Sheet 1 of 4).	0004-1

TABLE OF CONTENTS - Continued

	<u>Page No.</u>
	<u>WP Sequence No.</u>
Figure 1. Operator Controls and Indicators (Sheet 2 of 4)	0004-2
Figure 1. Operator Controls and Indicators (Sheet 3 of 4)	0004-3
Figure 1. Operator Controls and Indicators (Sheet 4 of 4)	0004-4
Operator Controls and Indicators	0004-4
Operation Under Usual Conditions	WP 0005
General	0005-1
Installation of Ground Rods	0005-1
Figure 1. Grounding Connections (Typical Installation).....	0005-2
Installation of Load Cables	0005-2
Figure 2. Installation of Load Cables	0005-3
Priming and Bleeding the Fuel System	0005-3
Figure 3. Fuel Filter Bleed Screws	0005-4
Operating Procedures	0005-4
Manual Starting [23°F (-5°C) to 122°F (50°C)]	0005-5
Figure 4. Air Intake Cover, Normal Operation	0005-6
Electric Starting [23°F (-5°C) to 122°F (50°C)]	0005-6
Electric Starting [23°F (-5°C) to -5°F (-21°C)]	0005-7
Figure 5. Engine RUN and STOP Controls	0005-8
Electric Starting [Between -5°F (-21°C) to -25°F (-32°C)]	0005-9
Figure 6. Air Intake Cover, Cold Operation	0005-9
Figure 7. Adding Oil - Cylinder Head Cover Opening.....	0005-10
Stopping Procedure.....	0005-10
Identification and Instruction Plates.....	0005-11
Figure 8. Decals and Instruction Plates (Sheet 1 of 2).....	0005-12
Figure 8. Decals and Instruction Plates (Sheet 2 of 2).....	0005-13
Preparation for Movement.....	0005-13
Operation Under Unusual Conditions	WP 0006
Operation in Extreme Cold [23°F (-5°C) to -51°F (-46°C)].	0006-1
Operation in Extreme Heat [Above 120°F (49°C)].	0006-2
Operation in Dusty or Sandy Areas.....	0006-2
Operation in Rainy or Humid Conditions	0006-2
Operation in Salt Water Areas.....	0006-2
Operation at High Altitudes.....	0006-3
Operating Generator Set Output for High Altitudes and Temperatures.....	0006-3
Table 1. Altitude and Temperature Derating Calculation.....	0006-3
Chapter 3 - Operator Troubleshooting Procedures	
Operator Troubleshooting Index	WP 0007
Purpose of Logic Tree Table	0007-1
Operator Troubleshooting Procedures.....	WP 0008
Figure 1. Diesel Engine Will Not Start (Manual Starting).....	0008-2
Figure 2. Diesel Engine Will Not Start (Electric Starting).....	0008-3
Figure 3. Diesel Engine Runs Rough	0008-3
Figure 4. Voltage Output Drops.....	0008-4

TABLE OF CONTENTS - Continued

	Page No.
	<u>WP Sequence No.</u>
Figure 5. Generator Set Vibrating/Bouncing Excessively	0008-4
Figure 6. No Voltage Indication on VOLTS Meter (M2)	0008-5
Figure 7. Voltage Indication on VOLTS Meter (M2) is High, Low, or Fluctuating	0008-5
Figure 8. No Indication on % LOAD Meter (M1) With Load Applied.....	0008-6
Figure 9. No Indication on HERTZ Frequency Meter (M4) (MEP-531A)	0008-6
Figure 10. HOURS Meter (M3) Not Operating	0008-7
Figure 11. Excessive Voltage Drop When Applying Load	0008-7
Chapter 4 - Operator Maintenance Instructions	
Operator PMCS Introduction.....	WP 0009
Introduction to Operator PMCS Table	0009-1
Warnings and Cautions	0009-1
Operator PMCS	0009-1
Explanation of Table Entries.....	0009-1
Other Table Entries	0009-2
Reporting and Correcting Deficiencies	0009-2
PMCS, BEFORE Operations.....	0009-2
PMCS, DURING Operations	0009-2
After You Operate.....	0009-2
Order In Which PMCS Will be Done.....	0009-2
Fluid Leakage.....	0009-3
Table 1. Leakage Definitions.....	0009-4
Operator PMCS, Including Lubrication Instructions	WP 0010
Operator Lubrication Instructions	0010-1
Table 1. Operator Preventive Maintenance Checks and Services for MEP-501A/MEP-531A.....	0010-1
Mandatory Replacement Parts List	0010-5
Instrument Fuse (F1): Removal, Inspection, Installation.....	WP 0011
Removal	0011-1
Inspection	0011-1
Installation	0011-1
Figure 1. Fuse (F1) Replacement.....	0011-2
Chapter 5 - Field Troubleshooting Procedures	
Field Troubleshooting Index.....	WP 0012
Field Troubleshooting	0012-1
Field Troubleshooting Procedures	WP 0013
Figure 1. Diesel Engine Will Not Start (Manual Starting).....	0013-2
Figure 2. Diesel Engine Will Not Start (Electric Starting) (Sheet 1 of 2).....	0013-3
Figure 2. Diesel Engine Will Not Start (Electric Starting) (Sheet 2 of 2).....	0013-4
Figure 3. Diesel Engine Hard To Start.....	0013-5
Figure 4. Diesel Engine Starts but Fails to Keep Running	0013-6
Figure 5. Diesel Engine Runs Erratic (Sheet 1 of 2).....	0013-7
Figure 5. Diesel Engine Runs Erratic (Sheet 2 of 2).....	0013-8
Figure 6. Diesel Engine Runs Rough	0013-8

TABLE OF CONTENTS - Continued

	<u>Page No.</u>
	<u>WP Sequence No.</u>
Figure 7. Unexpected Reverse Rotation at Startup.....	0013-9
Figure 8. Diesel Engine Races Exceeding Governed Speed.....	0013-10
Figure 9. Diesel Engine Runs Unevenly (Surges).....	0013-10
Figure 10. Diesel Engine Seizes During Operation.....	0013-11
Figure 11. Diesel Engine Stops During Operation (Sheet 1 of 2).....	0013-12
Figure 11. Diesel Engine Stops During Operation (Sheet 2 of 2).....	0013-13
Figure 12. Diesel Engine Exhausts Black Smoke.....	0013-14
Figure 13. Diesel Engine Exhausts Blue-White Smoke.....	0013-15
Figure 14. Recoil Start Rope Hard to Pull.....	0013-16
Figure 15. Voltage Output Drops (MEP-531A).....	0013-17
Figure 16. Voltage Output Drops (MEP-501A).....	0013-18
Figure 17. No Output Voltage (MEP-531A).....	0013-19
Figure 18. No Output Voltage (MEP-501A).....	0013-19
Figure 19. Generator Set Vibrating/Bouncing Excessively.....	0013-20
Figure 20. No Voltage Indication on VOLTS Meter (M2).....	0013-21
Figure 21. No Indication on % LOAD Meter (M1) (MEP-531A).....	0013-22
Figure 22. No Indication on % LOAD Meter (M1) (MEP-501A).....	0013-23
Figure 23. No Indication on HERTZ Frequency Meter (M4) (MEP-531A).....	0013-24
Figure 24. No Indication on HOURS Meter (M3).....	0013-25
Figure 25. No Output from Alternator (MEP-531A).....	0013-26
Figure 26. No Output from Alternator (MEP-501A).....	0013-27
Figure 27. Air Intake Preheaters Do Not Operate.....	0013-28
Figure 28. Cannot Adjust Alternator Output With VOLTAGE ADJ. Potentiometer.....	0013-29
Chapter 6 - Field Maintenance Instructions	
Service Upon Receipt.....	WP 0014
Figure 1. Oil Level.....	0014-3
Field PMCS Introduction.....	WP 0015
Introduction to Field PMCS Table.....	0015-1
Warnings and Cautions.....	0015-1
Field PMCS.....	0015-1
Explanation of Table Entries.....	0015-1
Other Table Entries.....	0015-2
Reporting and Correcting Deficiencies.....	0015-2
Monthly.....	0015-2
Quarterly.....	0015-2
Semi-annually.....	0015-2
Bi-annually.....	0015-2
Hourly.....	0015-3
Order In Which PMCS Will be Done.....	0015-3
Fluid Leakage.....	0015-4
Table 1. Leakage Definitions.....	0015-4
Field PMCS, Including Lubrication Instructions.....	WP 0016
Field Lubrication Instructions.....	0016-1

TABLE OF CONTENTS - Continued

	Page No.
	<u>WP Sequence No.</u>
Table 1. Field Preventive Maintenance Checks and Services for MEP-501A/MEP-531A.	0016-1
Mandatory Replacement Parts List	0016-4
Fuel Filter Element Replacement: Removal, Installation	WP 0017
Removal	0017-1
Installation	0017-1
Figure 1. Fuel Filter Element Replacement	0017-2
Air Filter Element Replacement: Removal, Cleaning, Installation.....	WP 0018
Removal	0018-1
Cleaning	0018-1
Figure 1. Air Filter Elements	0018-2
Installation	0018-2
Fuel Injector Replacement: Removal, Inspection, Installation	WP 0019
Removal	0019-1
Inspection	0019-1
Figure 1. Fuel Injector Replacement	0019-2
Installation	0019-2
Alternator Brushes Inspection (MEP-531A): Removal, Inspection, Installation	WP 0020
Removal	0020-1
Figure 1. AC Alternator Brushes.....	0020-1
Inspection	0020-2
Installation	0020-2
Alternator Flexible Coupling Inspection (MEP-501A): Removal, Inspection, Installation.....	WP 0021
Removal	0021-1
Inspection	0021-1
Installation	0021-1
Figure 1. Alternator Flexible Coupling (MEP-501A)	0021-2
Engine Resilient Mounts Replacement: Removal, Installation.....	WP 0022
Removal	0022-1
Installation	0022-1
Alternator Resilient Mount Replacement (MEP-531A): Removal, Installation	WP 0023
Removal	0023-1
Installation	0023-1
Figure 1. Resilient Mounts.....	0023-2
Alternator Resilient Mount Replacement (MEP-501A): Removal, Installation	WP 0024
Removal	0024-1
Installation	0024-1
Figure 1. Alternator Resilient Mount (MEP-501A)	0024-2
Cylinder Head Nuts Tightening: Adjustment	WP 0025
Adjustment.....	0025-1
Figure 1. Torquing Cylinder Head Nuts	0025-2
Fuel Lines, Clamps, Fittings, Etc.: Removal, Installation	WP 0026

TABLE OF CONTENTS - Continued

	Page No.
	<u>WP Sequence No.</u>
Removal	0026-1
Figure 1. Fuel Lines, Clamps, Fittings (Typical)	0026-1
Installation	0026-2
Fuel Filter Assembly: Removal, Inspection, Installation.....	WP 0027
Removal	0027-1
Figure 1. Fuel Filter Assembly.....	0027-2
Inspection	0027-2
Installation	0027-2
Fuel Drain Cock: Removal, Installation.....	WP 0028
Removal	0028-1
Figure 1. Fuel Drain Cock.....	0028-1
Installation	0028-2
Fuel Tank Assembly: Removal, Disassembly, Inspection, Assembly, Installation.....	WP 0029
Removal	0029-1
Disassembly	0029-2
Inspection	0029-2
Figure 1. Fuel Tank Assembly.....	0029-3
Assembly	0029-4
Installation	0029-4
Air Intake System Components: Removal, Inspection, Installation.....	WP 0030
Removal	0030-1
Figure 1. Air Intake System Components.....	0030-1
Inspection	0030-1
Installation	0030-2
Exhaust System Components: Removal, Cleaning, Installation	WP 0031
Removal	0031-1
Cleaning	0031-1
Figure 1. Exhaust System Components	0031-2
Installation	0031-2
Figure 2. Spark Arrester Clamp Positioning	0031-3
Control Panel Assembly: Inspection, Removal, Repair, Installation	WP 0032
Inspection	0032-1
Removal	0032-1
Repair	0032-2
Installation	0032-2
Figure 1. Control Panel Assembly	0032-2
Instruction Plate(s): Removal, Installation.....	WP 0033
Removal	0033-1
Installation	0033-1
Figure 1. Instruction Plate(s)	0033-2
Instrument Cover: Inspection, Removal, Repair, Installation	WP 0034

TABLE OF CONTENTS - Continued

	Page No.
	<u>WP Sequence No.</u>
Inspection	0034-1
Removal	0034-1
Repair	0034-1
Installation	0034-2
Figure 1. Instrument Cover	0034-2
Instrument Panel: Inspection, Removal, Repair, Installation	WP 0035
Inspection	0035-1
Removal	0035-1
Figure 1. Instrument Panel	0035-2
Repair	0035-2
Installation	0035-2
Hertz Frequency Meter (MEP-531A): Inspection, Testing, Removal, Installation	WP 0036
Inspection	0036-1
Testing	0036-1
Removal	0036-1
Figure 1. HERTZ Frequency Meter (MEP-531A)	0036-2
Installation	0036-2
Volts Meter: Inspection, Testing, Removal, Installation	WP 0037
Inspection	0037-1
Testing	0037-1
Removal	0037-2
Figure 1. VOLTS Meter	0037-3
Installation	0037-3
% Load Meter: Inspection, Testing, Removal, Installation	WP 0038
Inspection	0038-1
Testing	0038-1
Removal	0038-3
Figure 1. % LOAD Meter	0038-3
Installation	0038-3
HOURS Meter: Inspection, Testing, Removal, Installation	WP 0039
Inspection	0039-1
Testing	0039-1
Removal	0039-2
Installation	0039-2
Figure 1. HOURS Meter	0039-2
VOLTAGE ADJ. Potentiometer: Inspection, Testing, Removal	WP 0040
Inspection	0040-1
Testing	0040-1
Removal	0040-1
Repair	0040-2
Installation	0040-2
Figure 1. VOLTAGE ADJ. Potentiometer	0040-2

TABLE OF CONTENTS - Continued

	Page No.
	<u>WP Sequence No.</u>
Instrument Shunt (MEP-501A): Inspection, Removal, Testing, Installation	WP 0041
Inspection	0041-1
Removal	0041-1
Figure 1. Instrument Shunt (MEP-501A)	0041-2
Testing.....	0041-2
Installation	0041-2
Capacitor (MEP-501A): Inspection, Removal, Testing, Repair, Installation.....	WP 0042
Inspection	0042-1
Removal	0042-1
Testing.....	0042-1
Figure 1. Capacitor (MEP-501A)	0042-2
Repair	0042-2
Installation	0042-2
Transient Suppressor Assembly (MEP-501A): Inspection, Removal, Testing, Repair, Installation	WP 0043
Inspection	0043-1
Removal	0043-1
Testing.....	0043-1
Figure 1. Transient Suppressor Assembly (MEP-501A).....	0043-2
Repair	0043-2
Installation	0043-2
Fuseholder(s): Inspection, Removal, Installation	WP 0044
Inspection	0044-1
Removal	0044-1
Installation	0044-1
Figure 1. Fuseholder(s)	0044-2
Ground Strap(s): Inspection, Removal, Installation	WP 0045
Inspection	0045-1
Removal	0045-1
Installation	0045-1
Figure 1. Ground Strap(s).....	0045-2
GFCI Receptacle and Receptacle Cover (MEP-531A): Inspection, Testing, Removal, Installation	WP 0046
Inspection	0046-1
Testing.....	0046-1
Removal	0046-1
Figure 1. GFCI Receptacle and Receptacle Cover (MEP-531A)	0046-2
Installation	0046-2
START-PREHEAT/PREHEAT/OFF/START Rotary Switch: Inspection, Testing, Removal, Installation.....	WP 0047
Inspection	0047-1
Testing.....	0047-1
Removal	0047-1
Installation	0047-2

TABLE OF CONTENTS - Continued

	Page No.
	<u>WP Sequence No.</u>
Figure 1. START-PREHEAT/PREHEAT/OFF/START Rotary Switch	0047-2
Discharge Varistor: Inspection, Testing, Removal, Installation.....	WP 0048
Inspection	0048-1
Testing.....	0048-1
Removal	0048-1
Installation	0048-1
Figure 1. Discharge Varistor.....	0048-2
NATO Slave Receptacle: Inspection, Removal, Installation	WP 0049
Inspection	0049-1
Removal	0049-1
Figure 1. NATO Slave Receptacle	0049-2
Installation	0049-2
Load Terminal(s) (MEP-501A and Mechron Sets): Inspection, Removal, Installation	WP 0050
Inspection	0050-1
Removal	0050-1
Figure 1. Load Terminal(s) (MEP-501A and Mechron Sets)	0050-2
Installation	0050-2
Terminal Board: Inspection, Removal, Testing, Installation.....	WP 0051
Inspection	0051-1
Removal	0051-1
Testing.....	0051-1
Figure 1. Terminal Board.....	0051-2
Installation	0051-2
Load Terminal Board (MEP-501A and Mechron Sets): Inspection, Removal, Installation.....	WP 0052
Inspection	0052-1
Removal	0052-1
Installation	0052-1
Figure 1. Load Terminal Board (MEP-501A and Mechron Sets).....	0052-2
ON-OFF Load Circuit Breaker Assembly and Boot: Inspection, Testing, Removal, Installation	WP 0053
Inspection	0053-1
Testing MEP-531A	0053-1
Testing MEP-501A	0053-2
Removal	0053-2
Installation	0053-2
Figure 1. ON-OFF Load Circuit Breaker Assembly and Boot.....	0053-3
Flywheel Diode Assembly: Inspection, Testing, Removal, Repair, Installation.....	WP 0054
Inspection	0054-1
Testing.....	0054-1
Removal	0054-1
Repair.....	0054-2
Figure 1. Flywheel Diode Assembly	0054-2
Installation	0054-2

TABLE OF CONTENTS - Continued

	<u>Page No.</u> <u>WP Sequence No.</u>
Diesel Engine Wiring Harness and Gasket, Control Panel: Inspection, Testing, Removal, Repair, Installation	WP 0055
Inspection	0055-1
Testing	0055-1
Removal	0055-2
Repair	0055-2
Figure 1. Diesel Engine Wiring Harness and Gasket, Control Panel	0055-2
Installation	0055-2
Alternator Wiring Harness and Gasket, Control Panel: Inspection, Testing, Removal, Repair, Installation	WP 0056
Inspection	0056-1
Testing	0056-1
Removal	0056-1
Figure 1. Alternator Wiring Harness and Gasket, Control Panel	0056-2
Repair	0056-2
Installation	0056-2
Electrical Lead Wire(s) (Typical): Inspection, Testing, Removal, Installation	WP 0057
Inspection	0057-1
Testing	0057-1
Removal	0057-1
Installation	0057-2
Figure 1. Electrical Lead Wire(s) (Typical)	0057-2
Load Terminal Board Cover (Lug Cover): Inspection, Removal, Repair, Installation	WP 0058
Figure 1. Load Terminal Board Cover (Lug Cover)	0058-1
Inspection	0058-1
Removal	0058-2
Repair	0058-2
Installation	0058-2
Electromagnetic Interference (EMI) Filter (MEP-531A): Inspection, Removal, Testing, Installation	WP 0059
Inspection	0059-1
Removal	0059-1
Figure 1. EMI Filter (MEP-531A)	0059-2
Testing	0059-2
Installation	0059-3
Low Oil Pressure (LOP) Switch: Testing, Removal, Installation	WP 0060
Testing	0060-1
Figure 1. Low Oil Pressure (LOP) Switch	0060-1
Removal	0060-2
Installation	0060-2
Low Oil Pressure (LOP) Solenoid Assembly: Testing, Removal, Cleaning and Inspection, Repair, Installation	WP 0061
Testing	0061-1

TABLE OF CONTENTS - Continued

	Page No.
	<u>WP Sequence No.</u>
Removal	0061-1
Cleaning	0061-2
Figure 1. Low Oil Pressure (LOP) Solenoid Assembly	0061-2
Repair	0061-3
Installation	0061-3
Low Oil Pressure (LOP) Engine Shutdown Cable: Inspection, Removal, Installation, Adjustment.....	WP 0062
Figure 1. Low Oil Pressure (LOP) Engine Shutdown Cable	0062-1
Inspection	0062-1
Removal	0062-2
Installation	0062-2
Adjustment.....	0062-2
Figure 2. LOP Engine Shutdown Cable Adjustment.....	0062-3
Air Intake Heating Elements and Pipe: Removal, Inspection, Testing, Installation.....	WP 0063
Removal	0063-1
Inspection	0063-1
Figure 1. Air Intake Heating Elements and Pipe.....	0063-2
Testing.....	0063-2
Installation	0063-2
Governor Regulator Bracket: Removal, Inspection, Repair, Installation.....	WP 0064
Removal	0064-1
Inspection	0064-1
Repair	0064-1
Installation	0064-1
Figure 1. Governor Regulator Bracket.....	0064-2
Figure 2. Governor Spring Positioning	0064-3
Cooling Fan Cover: Inspection, Removal, Repair, Installation.....	WP 0065
Inspection	0065-1
Removal	0065-1
Repair	0065-1
Figure 1. Cooling Fan Cover	0065-2
Installation	0065-2
Recoil Starter Assembly: Inspection, Removal, Installation.....	WP 0066
Inspection	0066-1
Removal	0066-1
Figure 1. Recoil Starter Assembly	0066-2
Installation	0066-2
Engine Oil Strainer: Removal, Cleaning, Installation	WP 0067
Removal	0067-1
Figure 1. Engine Oil Strainer	0067-2
Cleaning	0067-2
Installation	0067-2

TABLE OF CONTENTS - Continued

	Page No.
	<u>WP Sequence No.</u>
Valve Cover: Removal, Inspection, Installation.....	WP 0068
Removal	0068-1
Inspection	0068-1
Installation	0068-1
Figure 1. Valve Cover.....	0068-2
Starter Assembly (MEP-501A): Removal, Installation	WP 0069
Removal	0069-1
Installation	0069-1
Figure 1. Starter Assembly	0069-2
Engine Wiring Harness: Inspection, Removal, Disassembly, Repair, Installation	WP 0070
Inspection	0070-1
Removal	0070-1
Disassembly	0070-1
Figure 1. Engine Wiring Harness.....	0070-2
Repair	0070-2
Installation	0070-3
Alternator Wiring Harness (MEP-501A): Inspection, Testing, Removal, Repair, Installation.....	WP 0071
Inspection	0071-1
Testing.....	0071-1
Figure 1. Alternator Wiring Harness	0071-2
Removal	0071-2
Repair	0071-2
Installation	0071-3
Preheater Lead: Inspection, Testing, Removal, Repair, Installation	WP 0072
Inspection	0072-1
Testing.....	0072-1
Removal	0072-1
Repair	0072-1
Figure 1. Preheater Lead.....	0072-2
Installation	0072-2
Ground Stud Terminal: Inspection, Removal, Installation.....	WP 0073
Inspection	0073-1
Removal	0073-1
Installation	0073-1
Figure 1. Ground Stud Terminal.....	0073-2
Generator Control Unit: Inspection, Testing, Removal, Installation	WP 0074
Inspection	0074-1
Testing MEP-531A	0074-1
Testing MEP-501A	0074-2
Removal	0074-3
Installation	0074-3
Figure 1. Generator Control Unit (MEP-531A)	0074-4

TABLE OF CONTENTS - Continued

	Page No.
	<u>WP Sequence No.</u>
Voltage Regulator Assembly: Inspection, Testing, Removal, Installation	WP 0075
Inspection	0075-1
Testing MEP-531A	0075-1
Testing MEP-501A	0075-2
Removal	0075-2
Figure 1. Voltage Regulator Assembly (MEP-531A)	0075-3
Installation	0075-3
Diesel Engine Wiring Harness, Control Panel: Testing, Repair	WP 0076
Testing	0076-1
Repair	0076-1
Alternator Wiring Harness, Control Panel: Testing, Repair	WP 0077
Testing	0077-1
Repair	0077-1
Engine/Alternator Assembly: Removal, Installation	WP 0078
Removal	0078-1
Figure 1. Engine/Alternator Assembly	0078-2
Installation	0078-3
Diesel Engine: Installation, Removal	WP 0079
Removal	0079-1
Installation	0079-1
Starter (MEP-531A): Removal, Installation	WP 0080
Removal	0080-1
Figure 1. Starter (MEP-531A)	0080-1
Installation	0080-2
Rocker Arms and Push Rods: Removal, Inspection, Installation	WP 0081
Removal	0081-1
Inspection	0081-1
Installation	0081-1
Figure 1. Rocker Arms and Push Rods Assembly	0081-2
Cylinder Head Assembly: Removal, Inspection, Installation	WP 0082
Removal	0082-1
Figure 1. Cylinder Head Assembly	0082-2
Inspection	0082-2
Installation	0082-2
Intake and Exhaust Valves: Removal, Inspection, Installation, Adjustment	WP 0083
Removal	0083-1
Figure 1. Intake and Exhaust Valves	0083-1
Inspection	0083-2
Figure 2. Valve Seat Measurements	0083-2
Figure 3. Measuring Valve Sinkage	0083-2
Installation	0083-3

TABLE OF CONTENTS - Continued

	Page No.
	<u>WP Sequence No.</u>
Adjustment.....	0083-3
Figure 4. T Position Mark	0083-3
Figure 5. Valve Adjustment	0083-4
Fuel Injection Pump: Removal, Inspection, Installation, Adjustment	WP 0084
Removal	0084-1
Figure 1. Fuel Injection Pump Removal	0084-2
Inspection	0084-2
Installation	0084-2
Figure 2. Governor Linkage Setting.....	0084-3
Figure 3. Fuel Injection Limitation Setting	0084-3
Adjustment.....	0084-3
Figure 4. T Position Mark	0084-4
Crankcase Cover: Removal, Inspection, Installation	WP 0085
Removal	0085-1
Inspection	0085-1
Installation	0085-2
Figure 1. Crankcase Cover.....	0085-
Oil Pump Assembly: Removal, Inspection, Installation.....	WP 0086
Removal	0086-1
Figure 1. Oil Pump Assembly	0086-1
Inspection	0086-2
Installation	0086-2
Flywheel: Removal, Inspection, Installation	WP 0087
Removal	0087-1
Figure 1. Flywheel Locking Handle	0087-1
Figure 2. Flywheel	0087-2
Inspection	0087-2
Installation	0087-2
Dynamo: Testing, Removal, Inspection, Installation	WP 0088
Testing.....	0088-1
Removal	0088-1
Figure 1. Aligning Timing Marks	0088-2
Inspection	0088-2
Installation	0088-2
Figure 2. Dynamo	0088-3
AC Alternator Assembly (MEP-531A): Removal, Disassembly, Assembly, Inspection, Testing, Installation.....	WP 0089
Removal	0089-1
Figure 1. AC Alternator Assembly (MEP-531A) (Sheet 1 of 2).....	0089-2
Figure 1. AC Alternator Assembly (MEP-531A) (Sheet 2 of 2).....	0089-3
Disassembly	0089-3
Assembly	0089-4

TABLE OF CONTENTS - Continued

	Page No.
	<u>WP Sequence No.</u>
Table 1. Power Harness Connector Plug Connections	0089-4
Inspection	0089-4
Testing (alternator Installed)	0089-5
Installation	0089-5
AC Alternator Bearing (MEP-531A): Removal, Installation	WP 0090
Removal	0090-1
Figure 1. AC Alternator Bearing	0090-1
Installation	0090-2
DC Alternator Assembly (MEP-501A): Removal, Disassembly, Inspection, Testing, Assembly, Installation	WP 0091
Removal	0091-1
Figure 1. DC Alternator Installation (MEP-501A)	0091-2
Disassembly	0091-2
Figure 2. DC Alternator Assembly	0091-3
Figure 3. Heatsink Tie Point Locations	0091-4
Inspection	0091-4
Testing	0091-4
Figure 4. Brush Assembly Test	0091-5
Figure 5. Stator Test	0091-6
Figure 6. Rotor Test	0091-6
Assembly	0091-7
Installation	0091-7
DC Alternator Bearings (MEP-501A): Inspection, Removal, Installation	WP 0092
Inspection	0092-1
Removal	0092-1
Figure 1. Alternator Bearing Replacement	0092-2
Installation	0092-2
DC Alternator Diodes and Capacitors (MEP-501A): Removal, Testing, Installation	WP 0093
Removal	0093-1
Figure 1. Diodes and Capacitor Replacement	0093-2
Testing	0093-2
Installation	0093-3
Frame: Inspection, Removal, Repair, Installation	WP 0094
Inspection	0094-1
Figure 1. Frame	0094-2
Removal	0094-2
Repair	0094-2
Installation	0094-3
2 kW Deprocessing Checklist	WP 0095
Dewey/Mechron Cross-Reference List	WP 0096
Table 1. MEP-531A Cross-Reference List for Component Identifiers	0096-1
Table 2. MEP-531A Cross-Reference List for Wiring Identifiers	0096-2

TABLE OF CONTENTS - Continued

	Page No.
	<u>WP Sequence No.</u>
Table 3. MEP-501A Cross-Reference List for Component Identifiers	0096-4
Table 4. MEP-501A Cross-Reference List for Wiring Identifiers.	0096-5
Electrical Lead Fabrication for Control Panel.....	WP 0097
Table 1. Electrical Lead Fabrication for Control Panel (MEP-531A).	0097-1
Table 2. Electrical Lead Fabrication for Control Panel (MEP-501A).	0097-2
Illustrated List of Manufactured Items Introduction	WP 0098
Potentiometer, VOLTAGE ADJ. (P/N: 95-8077)	WP 0099
Figure 1. Potentiometer, VOLTAGE ADJ. (P/N: 95-8077) (Sheet 1 of 2).....	0099-1
Figure 1. Potentiometer, VOLTAGE ADJ. (P/N: 95-8077) (Sheet 2 of 2).....	0099-2
Potentiometer, VOLTAGE ADJ. (P/N: 95-8014)	WP 0100
Figure 1. Potentiometer, VOLTAGE ADJ. (P/N: 95-8014) (Sheet 1 of 2).....	0100-1
Figure 1. Potentiometer, VOLTAGE ADJ. (P/N: 95-8014) (Sheet 2 of 2).....	0100-2
Flywheel Diode Assembly (P/N: 95-8050)	WP 0101
Figure 1. Flywheel Diode Assembly (P/N: 95-8050).....	0101-1
Capacitor Assembly (P/N: 95-8017)	WP 0102
Figure 1. Capacitor Assembly (P/N: 95-8017).....	0102-1
LOP Solenoid Valve Assembly (P/N: 95-8019).....	WP 0103
Figure 1. LOP Solenoid Valve Assembly (P/N: 95-8019).....	0103-1
Wiring Harness, Control Panel (P/N: 95-8084)	WP 0104
Figure 1. Wiring Harness, Control Panel (P/N: 95-8084) (Sheet 1 of 2).....	0104-1
Figure 1. Wiring Harness, Control Panel (P/N: 95-8084) (Sheet 2 of 2).....	0104-2
Wiring Harness, Control Panel (P/N: 95-8023)	WP 0105
Figure 1. Wiring Harness, Control Panel (P/N: 95-8023) (Sheet 1 of 2).....	0105-1
Figure 1. Wiring Harness, Control Panel (P/N: 95-8023) (Sheet 2 of 2).....	0105-2
Wiring Harness, Control Panel (P/N: 95-8075)	WP 0106
Figure 1. Wiring Harness, Control Panel (P/N: 95-8075) (Sheet 1 of 2).....	0106-1
Figure 1. Wiring Harness, Control Panel (P/N: 95-8075) (Sheet 2 of 2).....	0106-2
Wiring Harness, Control Panel (P/N: 95-8022)	WP 0107
Figure 1. Wiring Harness, Control Panel (P/N: 95-8022) (Sheet 1 of 2).....	0107-1
Figure 1. Wiring Harness, Control Panel (P/N: 95-8022) (Sheet 2 of 2).....	0107-2
Wiring Harness, Engine (P/N: 95-8029).....	WP 0108
Figure 1. Wiring Harness, Engine (P/N: 95-8029) (Sheet 1 of 3).	0108-2
Figure 1. Wiring Harness, Engine (P/N: 95-8029) (Sheet 2 of 3).	0108-3
Figure 1. Wiring Harness, Engine (P/N: 95-8029) (Sheet 3 of 3).	0108-4
LOP Shutdown Cable (P/N: 95-8082).....	WP 0109
Figure 1. LOP Shutdown Cable (P/N: 95-8082)	0109-1
Preheater Lead, Electrical (P/N: 95-8141)	WP 0110
Figure 1. Preheater Lead, Electrical (P/N: 95-8141) (Sheet 1 of 2).....	0110-1
Figure 1. Preheater Lead, Electrical (P/N: 95-8141) (Sheet 2 of 2).....	0110-2

TABLE OF CONTENTS - Continued

	Page No.
	<u>WP Sequence No.</u>
Wiring Harness, Alternator (P/N: 95-8028)	WP 0111
Figure 1. Wiring Harness, Alternator (P/N: 95-8028) (Sheet 1 of 2).....	0111-1
Figure 1. Wiring Harness, Alternator (P/N: 95-8028) (Sheet 2 of 2).....	0111-2
Transient Suppressor (P/N: 95-8025)	WP 0112
Figure 1. Transient Suppressor (P/N: 95-8025)	0112-1
Flywheel Locking Handle (P/N: 114250-92101)	WP 0113
Figure 1. Flywheel Locking Handle (P/N: 114250-92101).....	0113-1
Flywheel Extractor (P/N: 114250-92130).....	WP 0114
Figure 1. Flywheel Extractor (P/N: 114250-92130)	0114-1
Torque Limits	WP 0115
How to Use the Torque Tables.....	0115-1
Table 1. Torque Limits for Steel Fasteners.	0115-2
Table 2. Torque Limits for Brass Fasteners.	0115-2
Table 3. Torque Limits for Metric Fasteners into Steel.....	0115-2
Chapter 7 - Parts Information	
Introduction	WP 0116
Table 1. SMR Code Explanation.	0116-1
GROUP 00 Generator Set Assembly, 2 kW (MEP-531A/501A)	WP 0117
Figure 1. Generator Set Assembly, 2 kW (MEP-531A/501A) (Sheet 1 of 2).....	0117-1
Figure 1. Generator Set Assembly, 2 kW (MEP-531A/501A) (Sheet 2 of 2).....	0117-2
GROUP 01 Frame Assembly (MEP-531A/501A).....	WP 0118
Figure 2. Frame Assembly (MEP-531A/501A)	0118-2
GROUP 02 Fuel System Assembly (MEP-531A/501A)	WP 0119
Figure 3. Fuel System Assembly (MEP-531A/501A).....	0119-2
GROUP 0201 Fuel Tank Assembly	WP 0120
Figure 4. Fuel Tank Assembly.....	0120-2
GROUP 0202 Fuel Filter Assembly	WP 0121
Figure 5. Fuel Filter Assembly.....	0121-2
GROUP 03 Engine Alternator Assembly (MEP-531A).....	WP 0122
Figure 6. Engine Alternator Assembly (MEP-531A) (Sheet 1 of 2).	0122-1
Figure 6. Engine Alternator Assembly (MEP-531A) (Sheet 2 of 2).	0122-2
GROUP 03 Engine Alternator Assembly (MEP-501A).....	WP 0123
Figure 7. Engine Alternator Assembly (MEP-501A)	0123-2
GROUP 0301 Diesel Engine Modified	WP 0124
Figure 8. Diesel Engine Modified.....	0124-2
GROUP 030101 Diesel Engine Assembly	WP 0125
Figure 9. Diesel Engine Assembly.....	0125-2
GROUP 03010101 Cylinder Block Installation.....	WP 0126
Figure 10. Cylinder Block Installation	0126-2

TABLE OF CONTENTS - Continued

	Page No.
	<u>WP Sequence No.</u>
GROUP 03010102 Cylinder Head Installation.....	WP 0127
Figure 11. Cylinder Head Installation	0127-2
GROUP 03010103 Air Intake Pipe and Muffler	WP 0128
Figure 12. Air Intake Pipe and Muffler	0128-2
GROUP 03010104 Cam/Crankshaft/Balancer Installation	WP 0129
Figure 13. Cam/Crankshaft/Balancer Installation	0129-2
GROUP 03010105 Piston and Rod Assembly.....	WP 0130
Figure 14. Piston and Rod Assembly	0130-2
GROUP 03010106 Lube Oil Pump and Governor	WP 0131
Figure 15. Lube Oil Pump and Governor.....	0131-2
GROUP 03010107 Cooling/Starting Installation	WP 0132
Figure 16. Cooling/Starting Installation.....	0132-2
GROUP 03010108 Fuel Injection Pump/Injector Installation	WP 0133
Figure 17. Fuel Injection Pump/Injector Installation.....	0133-2
GROUP 03010109 Starting Motor and Dynamo Installation.....	WP 0134
Figure 18. Starting Motor and Dynamo Installation	0134-2
GROUP 0302 AC Alternator Assembly (MEP-531A).....	WP 0135
Figure 19. AC Alternator Assembly (MEP-531A)	0135-2
GROUP 0303 DC Alternator Assembly (MEP-501A).....	WP 0136
Figure 20. DC Alternator Assembly (MEP-501A) (Sheet 1 of 2).	0136-1
Figure 20. DC Alternator Assembly (MEP-501A) (Sheet 2 of 2).	0136-2
GROUP 04 Control Panel Assembly (MEP-531A).....	WP 0137
Figure 21. Control Panel Assembly (MEP-531A) (Sheet 1 of 3).	0137-2
Figure 21. Control Panel Assembly (MEP-531A) (Sheet 2 of 3).	0137-3
Figure 21. Control Panel Assembly (MEP-531A) (Sheet 3 of 3).	0137-4
GROUP 04 Control Panel Assembly (MEP-501A).....	WP 0138
Figure 22. Control Panel Assembly (MEP-501A) (Sheet 1 of 3).	0138-2
Figure 22. Control Panel Assembly (MEP-501A) (Sheet 2 of 3).	0138-3
Figure 22. Control Panel Assembly (MEP-501A) (Sheet 3 of 3).	0138-4
GROUP 0401 Control Panel Constructions (MEP-531A/501A).....	WP 0139
Figure 23. Control Panel Constructions (MEP-531A/501A)	0139-2
GROUP 0402 Voltage Adjust Potentiometer	WP 0140
Figure 24. Voltage Adjust Potentiometer.....	0140-2
GROUP 0407 LOP Shutdown Solenoid Assembly	WP 0141
Figure 25. LOP Shutdown Solenoid Assembly.....	0141-2
GROUP 0408 Control Panel Engine Wiring Harnesses (MEP-531A/501A)	WP 0142
Figure 26. Control Panel Engine Wiring Harnesses (MEP-531A/501A).....	0142-2
GROUP 0409 Control Panel Alternator Wiring Harnesses (MEP-531A/501A).....	WP 0143

TABLE OF CONTENTS - Continued

	Page No.
	<u>WP Sequence No.</u>
Figure 27. Control Panel Alternator Wiring Harnesses (MEP-531A/501A)	0143-2
GROUP 0411 Flywheel Diode Assembly	WP 0144
Figure 28. Flywheel Diode Assembly	0144-2
GROUP 0412 Control Panel Electrical Leads (MEP-531A)	WP 0145
Figure 29. Control Panel Electrical Leads (MEP-531A) (Sheet 1 of 5).....	0145-2
Figure 29. Control Panel Electrical Leads (MEP-531A) (Sheet 2 of 5).....	0145-3
Figure 29. Control Panel Electrical Leads (MEP-531A) (Sheet 3 of 5).....	0145-4
Figure 29. Control Panel Electrical Leads (MEP-531A) (Sheet 4 of 5).....	0145-5
Figure 29. Control Panel Electrical Leads (MEP-531A) (Sheet 5 of 5).....	0145-6
GROUP 0412 Control Panel Electrical Leads (MEP-501A)	WP 0146
Figure 30. Control Panel Electrical Leads (MEP-501A) (Sheet 1 of 6).....	0146-1
Figure 30. Control Panel Electrical Leads (MEP-501A) (Sheet 2 of 6).....	0146-2
Figure 30. Control Panel Electrical Leads (MEP-501A) (Sheet 3 of 6).....	0146-3
Figure 30. Control Panel Electrical Leads (MEP-501A) (Sheet 4 of 6).....	0146-4
Figure 30. Control Panel Electrical Leads (MEP-501A) (Sheet 5 of 6).....	0146-5
Figure 30. Control Panel Electrical Leads (MEP-501A) (Sheet 6 of 6).....	0146-6
GROUP 0413 Capacitor Assembly (MEP-501A)	WP 0147
Figure 31. Capacitor Assembly (MEP-501A).....	0147-2
GROUP 0414 Transient Suppressor Assembly (MEP-501A)	WP 0148
Figure 32. Transient Suppressor Assembly (MEP-501A).....	0148-2
GROUP 05 Engine Wiring Harness (MEP-531A/501A)	WP 0149
Figure 33. Engine Wiring Harness (MEP-531A/501A)	0149-2
GROUP 06 LOP Engine Shutdown Cable Assembly (MEP-531A/501A)	WP 0150
Figure 34. LOP Engine Shutdown Cable Assembly (MEP-531A/501A).....	0150-2
GROUP 07 Preheater Lead Assembly (MEP-531A/501A)	WP 0151
Figure 35. Preheater Lead Assembly (MEP-531A/501A).....	0151-2
GROUP 08 Alternator Wiring Harness (MEP-501A)	WP 0152
Figure 36. Alternator Wiring Harness (MEP-501A)	0152-2
Bulk Items	WP 0153
Special Tools List.....	WP 0154
Figure 1. Special Tools for Field Maintenance (Diesel Engine).....	0154-2
NSN Index.....	WP 0155
Table 1. NSN Index.	0155-1
P/N Index	WP 0156
Table 1. Part Number Index.	0156-1
Chapter 8 - Supporting Information	
References.....	WP 0157
Introduction for Standard Two-Level Maintenance MAC	WP 0158
The Army Maintenance System MAC	0158-1

TABLE OF CONTENTS - Continued

	Page No.
	<u>WP Sequence No.</u>
Explanation of Columns in the MAC.....	0158-3
Explanation of Columns In the Tools and Test Equipment Requirements	0158-3
Explanation of Columns In the Remarks	0158-4
MAC	WP 0159
Table 1. MAC for 2 kW Military Tactical Generator Sets.....	0159-1
Table 2. Tools and Test Equipment Requirements for 2 kW Military Tactical Generator Sets.....	0159-4
Table 3. Remarks for 2 kW Military Tactical Generator Sets.....	0159-5
Components of End Item (COEI) and Basic Issue Items (BII) Lists.....	WP 0160
Table 1. Components of End Item List.....	0160-1
Figure 1. Technical Manual TM 9-6115-673-13&P and Ground Rod Electrical Equipment	0160-2
Table 2. Basic Issue Items List.....	0160-2
Additional Authorization List (AAL)	WP 0161
Table 1. Additional Authorization List.....	0161-1
Expendable and Durable Items List.....	WP 0162
Table 1. Expendable and Durable Items List.....	0162-1
Mandatory Replacement Parts List.....	WP 0163
Table 1. Mandatory Replacement Parts List.....	0163-1
Special Packaging Instructions	WP 0164
Figure 1. Special Packaging Instructions, MEP-531A (Sheet 1 of 2).....	0164-1
Figure 1. Special Packaging Instructions, MEP-531A (Sheet 2 of 2).....	0164-2
Figure 2. Special Packaging Instructions, MEP-501A (Sheet 1 of 2).....	0164-3
Figure 2. Special Packaging Instructions, MEP-501A (Sheet 2 of 2).....	0164-4
Components and Instructions for Auxiliary Fuel System	WP 0165
Scope	0165-1
General.....	0165-1
Item Description.....	0165-1
Explanation of Columns - Figure 1	0165-1
Auxiliary Fuel System Instructions.....	0165-2
Fabrication Instructions	0165-2
Tools Required for Pre-assembly, Assembly, and Disassembly	0165-2
Pre-assembly Instructions	0165-2
Disassembly Instructions.....	0165-4
Figure 1. Auxiliary Fuel System (Sheet 1 of 2).....	0165-5
Figure 1. Auxiliary Fuel System (Sheet 2 of 2).....	0165-6
Table 1. Auxiliary Fuel System Components.....	0165-7
Figure 2. Three Way Valve Bracket.....	0165-8
Figure 3. Auxiliary Fuel Tank Bracket.....	0165-9
Figure 4. 2 kW Set with Auxiliary Fuel System Installed	0165-10
Figure 5. Fuel Can Bracket Shown in the Stowed Position	0165-11
Index	
Foldout Figures	
FO 1.	FP-1

TABLE OF CONTENTS - Continued

	Page No.
	<u>WP Sequence No.</u>
FO 2.	FP-3
FO 3.	FP-5
FO 4.	FP-7
FO 5.	FP-9
FO 6.	FP-11

How to Use This Manual

This manual contains operator and field maintenance instructions for the 2 kW Military Tactical Generator Sets.

NOTE

Throughout the family of manuals, directional orientation in relation to the equipment is described from the point of view of the operator facing the operator's controls looking out over the equipment. From this perspective, the end of the equipment containing the operator's controls will be referred to as the rear.

This manual provides operating procedures, troubleshooting, maintenance, and supporting information required to operate and maintain the generator sets. Listed below are some of the features included in this TM to help locate and use the provided information.

WORK PACKAGES

This TM has been organized using the WP format. Each chapter contains a series of WPs rather than sections and paragraphs. Each WP is designed to stand alone as a complete information module; if the user keeps the section(s) of this TM in a loose-leaf binder, the user will be able to remove just the WP needed to complete a specific task. Here are some WP features of which the user should be aware.

Each WP is numbered using a four-digit number beginning with WP 0001. WPs are numbered sequentially throughout the TM (ex. WP 0016. WP 0020. etc.). The Table of Contents lists each chapter and WP title as well as all figures and tables contained within each. Figures and tables are numbered sequentially for each WP.

The WP number is located at the top right of each page. It is also located at the bottom of the page with the WP page number included (0001-1 would be page 1 of the General Information WP (WP 0001, General Information)).

Each WP starts on a right-hand page. This is done so the user can remove a single WP from the paper TM if needed for a task. Blank pages are assigned a number, but it appears on the preceding or following page. For example, if page 0001-10 of a WP is blank, page 0001-9 will have the number 0001-9/10 blank; or if page 0001-1 of a WP is blank, page 0001-2 will have the number 0001-1 blank/2.

Each WP containing step-by-step maintenance or troubleshooting procedures will end with the words END OF TASK, and each WP ends with the statement END OF WORK PACKAGE. Think of each WP as a small, standalone TM.

Typographical conventions are as follows:

[Unload] indicates a soft key or a switch.

[Previous] + [Next] indicates two simultaneous key presses. [+] [-] indicates two sequential key presses.

References to equipment Data and Description Plates are printed as they appear on the equipment whenever possible.

Warnings, Cautions and Notes Definitions

Warnings, cautions, notes, chapter titles, and paragraph headings are printed in bold type. Icons related to warnings are shown directly above the warning text.

The following definitions apply to WARNINGS, CAUTIONS and NOTES found throughout this publication. Warning, cautions and notes provide supplemental information. Personnel must understand and apply these Warnings, Cautions and Notes during many phases of operation and maintenance to ensure personnel safety and health and the protection of property. Portions of this information may be repeated in certain chapters of this publication for emphasis.

WARNING

A warning identifies a clear danger to the person doing that procedure.

CAUTION

A caution identifies risk of damage to the equipment.

NOTE

A note highlights essential procedures, conditions, or statements or conveys important instructional data to the user.

CHAPTER OVERVIEW

Chapter 1 - General Information, Equipment Description and Theory of Operation

Chapter 1 provides an introduction to the generator sets. It is divided into three work packages, as follows:

General Information. This work package provides general information about this manual and the related forms and records. Instructions are provided for making equipment improvement recommendations. Coverage includes a reference to the TM that contains instructions on destruction of materiel to prevent enemy use. Also, a list of abbreviations and acronyms is provided. Also, a nomenclature cross-reference list is provided as well as a list of abbreviations and acronyms.

Equipment Description and Data. This work package describes capabilities, characteristics, and features. It provides basic equipment data and shows the locations of major components. Descriptions of the major components are also provided.

Theory of Operation. This work package provides functional descriptions of the equipment.

Chapter 2 - Operator Instructions

Chapter 2 provides instructions for operating the generator sets. The chapter is divided into three work packages, as follows:

Description and Use of Operator Controls and Indicators. This work package provides references to the applicable generator set technical manuals and trailer technical manuals. Those references contain information on operator controls and indicators for the equipment.

Operation Under Usual Conditions. This work package contains instructions for preparing the equipment for use and operation under normal conditions. Coverage includes connection instructions and preparation instructions for movement to a new worksite.

Operation Under Unusual Conditions. This work package provides unusual operating procedures or references to the applicable accompanying technical manuals.

Chapter 3 - Operator Troubleshooting Procedures

Chapter 3 covers troubleshooting procedures of the generator sets to be performed by the operator. The chapter is divided as follows:

Operator Troubleshooting Index. This work package provides a troubleshooting introduction and malfunction/symptom index to direct you to the appropriate troubleshooting procedure at the operator level.

Operator Troubleshooting Procedures. This work package provides troubleshooting procedures and corrective actions that are to be performed by the operator. It also provides references to the applicable technical manuals.

Chapter 4 - Operator Maintenance Instructions

Chapter 4 covers maintenance procedures for the generator sets to be performed by the operator. Its purpose is to provide you with the information that you need to keep the equipment in good operating condition. The chapter is divided as follows:

Operator Preventive Maintenance Checks and Services (PMCS) Introduction. This work package provides a detailed explanation of each table entry in the PMCS table along with applicable warnings, cautions and notes prior to starting on the PMCS procedures.

Operator Preventive Maintenance Checks and Services (PMCS), Including Lubrication Instructions. This work package contains detailed instructions that the operator must perform before, during, and after preventive maintenance checks and services. Coverage includes all operator PMCS for the equipment. It also provides references to the applicable lubrication instructions.

Operator Maintenance Procedures. These work packages refer the operator to the preventive maintenance checks and services required by WP 0010.

Chapter 5 - Field Troubleshooting Procedures

Chapter 5 covers troubleshooting procedures of the generator sets to be performed by field level maintenance. The chapter is divided as follows:

Field Troubleshooting Index. This work package provides a troubleshooting introduction and malfunction/symptom index to direct you to the appropriate troubleshooting procedure at the field maintenance level.

Field Troubleshooting Procedures. This work package covers troubleshooting procedures and corrective actions that are to be performed at the field maintenance level.

Chapter 6 - Field Maintenance

Chapter 6 provides instructions covering the generator sets maintenance that must be performed at field level. The chapter is divided as follows:

Service Upon Receipt. This work package contains instructions for inspecting and servicing the equipment when it is received. It includes instructions for unpacking the equipment when it is received. The instructions also include unpacking and stowing the basic issue items that accompany the generator sets. Also included are instructions on positioning the equipment for operation and connecting an external fuel source.

Field Preventive Maintenance Checks and Services (PMCS) Introduction. This work package provides a detailed explanation of each table entry in the PMCS table along with applicable warnings, cautions and notes prior to starting on the PMCS procedures.

Field Preventive Maintenance Checks and Services (PMCS). This work package contains instructions covering the PMCS that must be performed at the field maintenance level. A table provides information on maintenance intervals and actions required. References to the applicable lubrication instructions are also provided.

Field Maintenance Procedures. These work packages list the applicable references that cover field maintenance of the equipment.

Illustrated List of Manufactured Items. These work packages provide instructions for making the items authorized to be manufactured or fabricated at the field maintenance level.

Torque Limits. This work package lists standard torque values for bolts and screws used in maintaining the equipment.

Chapter 7 - Parts Information

This chapter contains Repair Parts and Special Tools Lists (RPSTL) needed to perform operator and field maintenance of the equipment. The chapter is divided as follows:

Repair Parts List. These work packages contain illustrations and lists. The illustrations aid in identifying the parts. The lists include information that tells which maintenance levels are authorized to use the part, the part number that identifies the part, the name of the part, and the quantity used.

Special Tools List. This work package lists special tools, special TMDE, and special support equipment authorized by the RPSTL.

National Stock Number (NSN) Index. This work package lists all of the parts contained in Repair Parts Lists. The NSN index is in National Item Identification Number (NIIN) sequence.

Part Number Index. These work packages lists all of the parts contained in Repair Parts Lists. The part number index is in alphanumeric part number sequence.

Chapter 8 - Supporting Information

The chapter is divided as follows:

References. This work package lists all publications referenced in the various chapters of the technical manual. The listing includes the title and document number of each publication.

Maintenance Allocation Chart (MAC) Introduction. This work package explains what is covered in the maintenance allocation chart.

Maintenance Allocation Chart (MAC). This work package has three sections, as follows:

Maintenance Allocation Chart (MAC). Table 1 contains a tabular listing that assigns maintenance functions to specific maintenance levels. It lists the work time needed to perform each maintenance function at the assigned level. It also contains a column that has entries keyed to the tools and equipment listed in Table 2.

Another column has entries keyed to the remarks in Table 3.

Tool and Test Equipment Requirements. Table 2 contains complete identification information for the items referenced in the tools and equipment column of Table 1.

Remarks. Table 3 provides additional information for each entry in the remarks column of Table 2.

Components of End Item (COEI) and Basic Issue Items (BI) Lists. This work package lists the items usually packaged separately but needed for installation and operation of the equipment. The work package has three sections, as follows:

Introduction. This section explains the entries in Tables 1 and 2.

Components of End Item. The equipment is normally shipped fully assembled, so this section is not applicable.

Basic Issue Items. This section contains a list of the accessories needed for installation and operation of the equipment.

Additional Authorization List (AAL). This work package lists additional items you are authorized for support of the equipment. This work package contains two sections, as follows:

Introduction. This section explains the entries in Tables 1.

Additional Authorized Items List. This table lists the Additional Authorized Items.

Expendable and Durable Items List. This work package lists expendable/durable supplies and materials needed to operate and maintain your equipment. The work package contains two sections, as follows:

Introduction. This section explains the entries in Tables 1.

Expendable and Durable Items List. The list indicates the maintenance level that needs each item and identifies the items by National Stock Number (NSN), description, and unit of measure.

Rear Matter

Alphabetical Index. An alphabetical index at the back of this technical manual provides a listing of subjects covered, cross-referenced to the applicable work packages.

HOW TO FIX AN EQUIPMENT MALFUNCTION

Determining the Cause

Finding the cause of a malfunction, troubleshooting, is the first step in fixing your equipment and returning it to operation. Follow these simple steps to determine the root of the problem:

1. Turn to the Table of Contents in this manual.
2. Locate "Troubleshooting" under the chapter that covers your level of maintenance. Turn to the page indicated.
3. For operator troubleshooting, follow the instructions in the references listed in Chapter 3.
4. For troubleshooting at the field level, find the malfunction listing in Chapter 5. Follow the instructions provided as indicated by the symptom index.

Preparing for a Task

Be sure that you understand the entire maintenance procedure before beginning any maintenance task. Make sure that all parts, materials, and tools are handy. Read all steps before beginning.

Prepare to do the task as follows:

1. Carefully read the entire task before starting. It tells you what you will need and what you have to know to start the task. **DO NOT START THE TASK UNTIL:**
 - a. You know what is needed
 - b. You have everything you need

- c. You understand what to do
2. If parts are listed, they can be drawn from technical supply. Before you start the task, check to make sure you can get the needed parts. National stock numbers (NSNs) and part numbers for generator set parts are listed in the Repair Parts and Special Tools List (RPSTL).
3. If expendable/durable supplies or materials are needed, get them before starting the task. Refer to WP 0162 for the correct nomenclature and NSN.

How to Do the Task

Before starting, read the entire task. Be sure that you understand the entire procedure before you begin the task. As you read, remember the following:

1. **PAY ATTENTION TO WARNINGS, CAUTIONS, AND NOTES.**
2. Use the List of Abbreviations/Acronyms if you do not understand the special abbreviations or unusual terms used in this manual.
3. The following are standard maintenance practices. Instructions about these practices are usually not included in task steps. When standard maintenance practices do not apply, the task steps will tell you.
 - a. Tag electrical wiring before disconnecting it.
 - b. Discard used preformed packing, retainers, gaskets, cotter pins, lockwashers, and similar items. Install new parts to replace the discarded items.
 - c. Coat packing before installation, in accordance with the task instructions.
 - d. Disassembly procedures describe the disassembly needed for total authorized repair. You may not need to disassemble an item as far as described in the task. Follow the Disassembly steps only as far as needed to repair/replace worn or damaged parts.
 - e. Clean the assembly, subassembly, or part before inspecting it..
 - f. Before installing components having mating surfaces, inspect the mating surfaces to make sure they are in serviceable condition.
 - g. Hold the bolt (or screw) head with a wrench (or screwdriver) while tightening or loosening a nut on the bolt (or screw).
 - h. Torque to the special torque cited when the task instructions include the words "torque to." Use standard torques at all other times.
 - i. When a cotter pin is required, align the cotter pin holes within the allowable torque range.
 - j. Inspect for foreign objects after performing maintenance.

CHAPTER 1

**OPERATOR AND FIELD GENERAL INFORMATION,
EQUIPMENT DESCRIPTION AND THEORY OF
OPERATION**

FOR

2 kW MILITARY TACTICAL GENERATOR SETS
MEP-531A
MEP-501A

CHAPTER 1

GENERAL INFORMATION, EQUIPMENT DESCRIPTION AND THEORY OF OPERATION

WORK PACKAGE INDEX

<u>Title</u>	<u>WP Sequence No.</u>
General Information.....	0001
Equipment Description and Data.....	0002
Theory of Operation.....	0003

OPERATOR AND FIELD MAINTENANCE
2 kW MEP-501A/531A MILITARY TACTICAL GENERATOR SETS
GENERAL INFORMATION

SCOPE**Type of Manual**

This manual contains operator procedures, field maintenance instructions for the Military Tactical Generator (MTG) Sets 2 kW 120 VAC 60 Hz and 28 VDC, and the Mechron 120 VAC and 28 VDC sets (Figure 1), herein referred to as generator set. Also included are descriptions of major components and their functions in relation to other components. See Table 1 for a list of model numbers and equipment names for the generator sets.

Table 1. Model Numbers and Equipment Names.

<u>Model Number</u>	<u>Equipment Name</u>
MEP-531A	Generator Set, Military Tactical, Diesel Powered, 2 kW 120 VAC Dewey Set, 120 VAC
MEP-531A	Generator Set, Military Tactical, Diesel Powered, 2 kW 120 VAC Mechron Set, 120 VAC
MEP-501A	Generator Set, Military Tactical, Diesel Powered, 2 kW 28 VDC Dewey Set, 28 VDC
MEP-501A	Generator Set, Military Tactical, Diesel Powered, 2 kW 28 VDC Mechron Set, 28 VDC

Purpose of Equipment

The generator set provides either 120 VAC, 60 Hertz or 28 VDC power. The generator set is easily transported, operated and maintained.

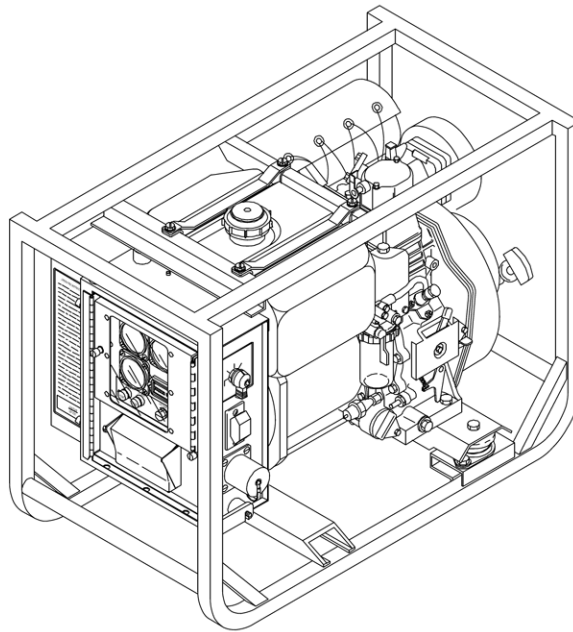

MEP-531A

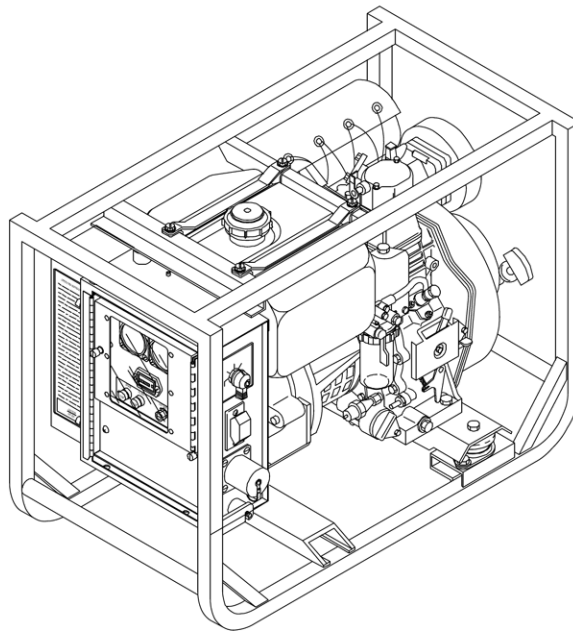

MEP-501A

Figure 1. Military Tactical Generator (MTG) Set - 2 kW.

MAINTENANCE FORMS, RECORDS, AND REPORTS

- (1) (A) Department of the Army forms and procedures used for equipment maintenance will be those prescribed by (as applicable) DA PAM 750-8, The Army Maintenance Management System (TAMMS) Users Manual; DA PAM 738-751, Functional Users Manual for the Army Maintenance Management Systems - Aviation (TAMMS-A); or AR 700-138, Army Logistics Readiness and Sustainability.
- (2) (F) Maintenance forms and records used by Air Force personnel are prescribed in AFI 21-101 and the applicable TO 00-20 Series Technical Orders.

REPORTING EQUIPMENT IMPROVEMENT RECOMMENDATION (EIR)

(A) If your generator set needs improvement, let us know. Send us an EIR. You, the user, are the only one who can tell us what you don't like about your equipment. Let us know why you don't like the design or performance. If you have Internet access, the easiest and fastest way to report problems or suggestions is to go to <https://aeps.ria.army.mil/aepspublic.cfm> (scroll down and choose the "Submit Quality Deficiency Report" bar). The Internet form lets you choose to submit an Equipment Improvement Recommendation (EIR), a Product Quality Deficiency Report (PQDR or a Warranty Claim Action (WCA). You may also submit your information using an SF 368 (Product Quality Deficiency Report). You can send your SF 368 via e-mail, regular mail, or facsimile using the addresses/facsimile numbers specified in DA PAM 750-8, The Army Maintenance Management System (TAMMS) Users Manual. We will send you a reply.

(F) USAF Deficiency Reporting and Investigating System, TO00-35D-54, Appendix A procedures will be used for electronic submission. Submit mailed SF368 forms to:

Robins AFB WRALC/LGMTC 375 Perry Street Robins AFB, GA 31098-1865

CORROSION PREVENTION AND CONTROL (CPC)

Corrosion Prevention and Control (CPC) of Army materiel is a continuing concern. It is important that any corrosion problems with this item be reported so that the problem can be corrected and improvements can be made to prevent the problem in future items.

Corrosion specifically occurs with metals. It is an electrochemical process that causes the degradation of metals. It is commonly caused by exposure to moisture, acids, bases, or salts. An example is the rusting of iron. Corrosion damage in metals can be seen, depending on the metal, as tarnishing, pitting, fogging, surface residue, and/or cracking.

Plastics, composites, and rubbers can also degrade. Degradation is caused by thermal (heat), oxidation (oxygen), solvation (solvents), or photolytic (light, typically UV) processes. The most common exposures are excessive heat or light. Damage from these processes will appear as cracking, softening, swelling, and/or breaking.

SF Form 368, Product Quality Deficiency Report should be submitted to the address specified in DA PAM 750-8, The Army Maintenance Management System (TAMMS) Users Manual.

DESTRUCTION OF ARMY MATERIEL TO PREVENT ENEMY USE

Destruction of the generator set to prevent enemy use shall be in accordance with TM 750-244-3.

PREPARATION FOR STORAGE OR SHIPMENT

Refer to TB 740-97-2/TO 35-1-4 for procedures to place the generator set into storage. Refer to ASTM D 3951-98 for procedures on preparing the generator set for shipment.

WARRANTY INFORMATION

The generator set is warranted by Dewey Electronics Corporation for a period of 12 months or 1200 operating hours, whichever occurs first. The warranty starts on the date found in block 23, DA Form 2408-9, in the logbook. Report all defects in material or workmanship to your supervisor, who will take appropriate action through your Field Maintenance Shop.

NOTE

This warranty does not apply to sets built by Mechron.

LIST OF ABBREVIATIONS/ACRONYMS

The following list of abbreviations consists of those special or unique abbreviations that are not contained in ASME-Y14.38M and do not conflict with those in ASME-Y14.38M.

<u>Abbreviation/Acronym</u>	<u>Name</u>
KPA	Kilopascal
KVA	Kilovolt-ampere
kW	Kilowatt
CTA	Common Table of Allowance
MTOE	Modified Table of Organization and Equipment
NATO	North Atlantic Treaty Organization
TDA	Table of Distribution and Allowance
JTA	Joint Table of Allowances
GFCI	Ground Fault Circuit Interrupter

SAFETY, CARE, AND HANDLING

Refer to the Warning Summary for a list of general safety precautions to be followed when operating and when performing maintenance on the generator set.

Critical Safety Items List

The following is a list of critical safety items for operating and maintaining the generator sets.

1. Ensure that the generator set is properly grounded. Refer to WP 0005, Installation of Ground Rods.
2. Ensure that the load cables are properly installed. Refer to WP 0005, Installation of Load Cables.
3. Diesel engine exhaust and some of its constituents are known in the State of California to cause cancer, birth defects, and other reproductive harm.

SUPPORTING INFORMATION FOR REPAIR PARTS, SPECIAL TOOLS, TMDE AND SUPPORT EQUIPMENT**Common Tools and Equipment**

For authorized common tools and equipment, refer to the Modified Table of Organization and Equipment (MTOE), CTA 50-970, or CTA 8-100, as applicable to your unit.

Special Tools, TMDE, and Support Equipment

There are no special tools or equipment required to perform field level maintenance on the generator set.

Repair Parts

Repair parts and equipment are listed and illustrated in the Parts Information (Chapter 6) covering field maintenance for this equipment.

END OF WORK PACKAGE

OPERATOR AND FIELD MAINTENANCE
2 kW MEP-501A/531A MILITARY TACTICAL GENERATOR SETS
EQUIPMENT DESCRIPTION AND DATA

EQUIPMENT CHARACTERISTICS, CAPABILITIES, AND FEATURES

General

The 2 kW generator sets, models MEP-501A and MEP-531A, (see WP 0001, Figure 1), are self-contained, skid mounted, portable units. They are equipped with controls, instruments and accessories necessary for operation as single units. The generator sets consist of a diesel engine, direct drive AC alternator, speed governing system, fuel system, 24 VDC auxiliary cold weather starting system, and generator control system. The generator sets are portable and require a four-person lift. The generator sets can also be stacked three high while in storage.

NOTE

For all locations referenced in procedures in this technical manual face the control panel at the rear of the generator set.

NOTE

This generator set can operate on DL- 1, DL- 2 & JP-8. No adjustments are necessary to run these alternate fuels.

LOCATION AND DESCRIPTION OF MAJOR COMPONENTS

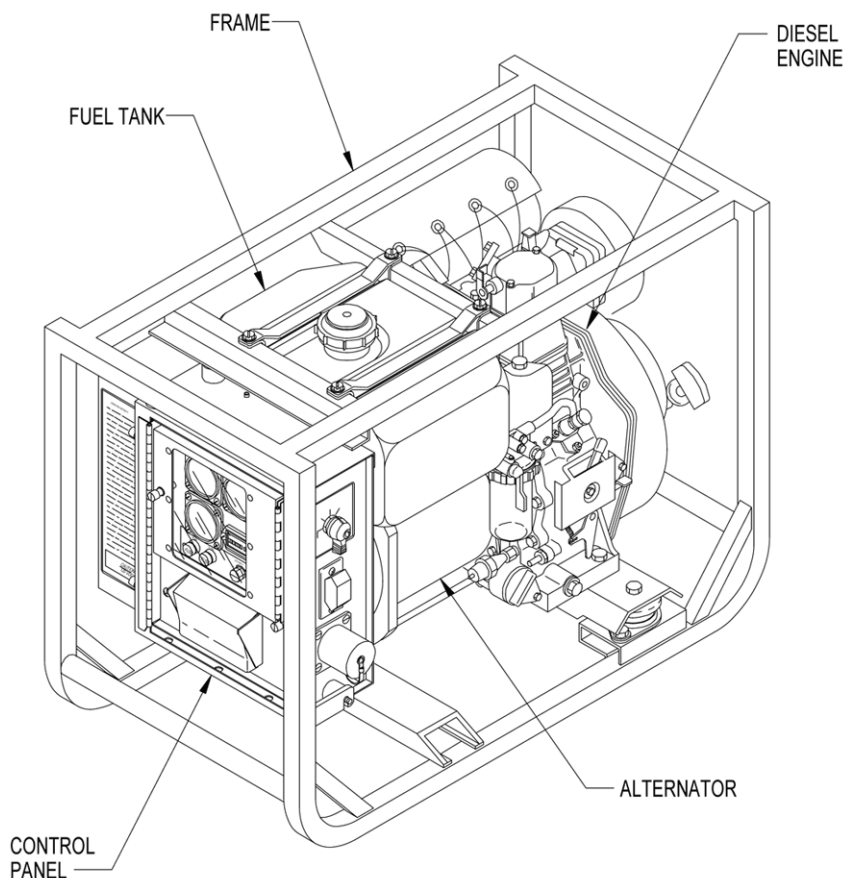

Figure 1. Location of Major Generator Set Components.

Diesel Engine

The generator set is powered by a one cylinder, four cycle, fuel injected, naturally-aspirated, air-cooled diesel engine which occupies the front half of the generator set. The engine is also equipped with a fuel filter, lubricating oil strainer, and a foam covered, dry-paper air filter. A safety device automatically stops the diesel engine during conditions of low engine oil pressure.

Alternator

The AC alternator is a single-bearing, drip-proof, synchronous, single phase, air-cooled generator. The DC alternator is a two-pole, revolving field-type AC alternator rectified to DC. Each alternator/generator is coupled directly to the diesel engine crankshaft.

Control Panel Assembly

The generator set control panel assembly is located at the rear of the generator set and contains controls and instruments for operating the engine and the alternator.

Fuel Tank

The 1.6 gallon (6.1 liters) fuel tank is located on top of the generator set just behind the diesel engine. The tank includes a removable strainer element designed to prevent large contaminants from entering the tank through the fill opening. The fuel tank has sufficient capacity to enable the generator set to operate for at least 4.8 hours without refueling while operating at 100% load.

Skid Base

The skid base supports the generator set.

Safety Devices

1. The generator set features a Low Oil Pressure (LOP) shutoff switch and solenoid which are designed to shut down the generator set if the diesel engine loses oil pressure. The LOP switch is located in the engine block (right-rear corner). The solenoid is located in the main control panel.
2. The convenience receptacle on the MEP-531A features a Ground Fault Circuit Interrupter (GFCI) which protects the generator set components from inductive current in the ground circuit originating from the load connected to the convenience receptacle. The convenience receptacle is located on the main control panel.
3. The ON-OFF load circuit breaker is designed to take the generator set off line in an overload condition. The circuit breaker is located on the right side of the main control panel. A circuit interrupter, internal to the circuit breaker, is connected between the alternator output and the generator set output terminals to disconnect the generator output from the load and also to protect the generator from a short circuit. The circuit interrupter is operated from a current sensor internal to the circuit breaker.
4. Transient suppressors (MEP-501A) protect the load circuit from potential damage caused by cross connecting the + and - output terminals of the alternator. The transient suppressors are located in the main control panel.

DIFFERENCES BETWEEN MODELS

The differences between models of the generator sets covered in this manual are as follows. Refer to Table 1.

1. Model MEP-531A is equipped with a 120 VAC, 60 Hz alternator.
2. Model MEP-501A is equipped with a 28 VAC alternator rectified for DC output.

This manual is written primarily for the Dewey configuration of generator sets. The differences between (MEP-531A and MEP-501A) models of generator sets and those built by Mechron are as follows:

Fuel Tank

Mechron sets do not include a fuel drain cock.

Fuel Filter Assembly

Air Force Mechron sets have a different fuel filter head with shutoff valve and bleed screws facing the engine. Army Mechron sets were issued a replacement which matches the Dewey configuration.

Low Oil Pressure Switch

Air Force Mechron 28 VDC sets do not include a coupler on this switch. Army Mechron 120 VAC sets have a new standard-to-metric coupler.

Convenience Receptacle

Mechron 120 VAC sets were issued without a Ground Fault Circuit Interrupter feature on the receptacle. This receptacle should be discarded and replaced.

Component and Wire Labeling

Labeling differences do exist. Cross-reference tables for components and wiring identifiers are provided in WP 0096 for the Mechron sets. Schematic and wiring diagrams are provided for both MEP-531A/501A and Mechron sets in Figures FO-1 through FO-6.

Part Numbers

The RPSTL should be used for ordering replacement parts for both configurations, Dewey and Mechron.

Electromagnetic Interference (EMI) Filter

The MEP-531A generator set features an EMI filter with integral load terminals in place of the load terminal boards found on the MEP-501A and Mechron sets.

EQUIPMENT DATA

Leading Particulars.

Table 1. Leading Particulars.

Item	Characteristic
1. Generator Set:	
Model Numbers:	
2 kW 120 VAC Military Tactical Generator Set	MEP-531A
2 kW 28 VDC Military Tactical Generator Set	MEP-501A
National Stock Numbers:	
MEP-531A	NSN 6115-01-435-1565
MEP-501A	NSN 6115-01-435-1567
Overall Length:	
MEP-531A	29.5 in. (750 mm)
MEP 501A	29.5 in. (750 mm)
Overall Width:	
MEP-531A	16 in. (406 mm)
MEP-501A	16 in. (406 mm)
Overall Height:	
MEP-531A	21.7 in. (550 mm)
MEP-501A	21.7 in. (550 mm)
Dry Weights:	
MEP-531A	143.1 lb (64.9 kg)
MEP-501A	123.5 lb (56.0 kg)

Table 1. Leading Particulars. - Continued

Item	Characteristic
2. Operating Environment:	
Temperature Range	-51 to 122 °F (-46 to 50 °C)
Incline Angle	15° max.
3. Diesel Engine:	
Manufacturer	Yanmar
Model	L48AE-DEG
Type	Single cylinder, four cycle, naturally-aspirated diesel
Stroke	2.2 in. (55 mm)
Displacement	12.88 cu in. (0.211 liters)
Compression Ratio	19.9:1
Rating	4.2 HP @ 3,600 RPM
Engine Operating Speed - No Load	3,750 RPM
Engine Operating Speed - Full Load (±30 RPM)	3,600 RPM
Altitude Degradation, 4,000 to 8,000 ft	1.3% per 328 feet (100 m)
Cold Weather Starting System Use	When temperature is 23 °F (-5 °C) or below
4. Diesel Engine Cooling System:	
Type	Air cooled by fan integral with flywheel
5. Diesel Engine Lubricating System:	
Type	Full flow, circulating pressure
Capacity	0.85 qt (0.80 liters)
Oil Pump Type	Gerotor
Normal Operating Pressure	25-60 psi
Filter Type	Reusable strainer
Pressure Indicating System	None
6. Fuel System:	
Type of Fuel	DL-1, DL-2, or JP8
Fuel Tank Capacity	1.6 gal. (6.1 liters)
Fuel Consumption Rate	0.333 gal./hr (1.26 liters/hr) @ 100% load
Full Tank Consumption	4.8 Hours @ 100% load
7. Diesel Engine Starting System:	
Manual	Recoil mechanism
Electric (Power supplied via NATO slave receptacle)	Starting motor
Manufacturer	Yanmar
Model	S114-414A
Rating	24 VDC
8. Alternator:	
MEP-531A:	
Manufacturer	Dewey Electronics Corporation
Type	Rotating field synchronous

NOTE

This generator set can operate on DL-1, DL-2, & JP-8. No adjustments are necessary to run these alternative fuels.

Table 1. Leading Particulars. - Continued

Item	Characteristic
Load Capacity	2 kW
Voltage Output	120 VAC single phase 2 wire and ground (bonded to frame)
Power Factor	1.0
Load Recovery Time (Voltage):	
NL to FL	3.0 seconds
FL to NL	3.0 seconds
Load Recovery Time (Frequency):	
NL to FL	4.0 seconds
FL to NL	5.0 seconds
Cooling	Forced air
Lubrication Requirements	None
Drive Type	Direct coupling
Duty Classification	Continuous
MEP-501A:	
Manufacturer	Balmar Products Inc.
Type	Brush AC rectified to DC
Load Capacity	2 kW
Voltage Output	28 VDC
Load Recovery Time (Voltage):	
NL to FL	1.0 seconds
FL to NL	0.5 seconds
Cooling	Forced air
Lubrication Requirements	None
Drive Type	Direct coupling
Duty Classification	Continuous
9. Safety Devices:	
Low Engine Oil Pressure:	
Trip Pressure (Range)	12-18 psi
Voltage Rating	24 VDC
Current Rating	5 amps
Method	Electrically-operated solenoid with mechanical link to fuel governor

END OF WORK PACKAGE

OPERATOR AND FIELD MAINTENANCE
2 kW MEP-501A/531A MILITARY TACTICAL GENERATOR SETS
THEORY OF OPERATION

INTRODUCTION

This work package contains functional descriptions of the generator set and explains how the controls and indicators interact with the system.

FUEL SYSTEM

NOTE

This generator set can operate on DL- 1, DL- 2 & JP-8.
No adjustments are necessary to run W-K-H-V-H alternative fuels.

The Generator Set Fuel System (Figure 1) provides filtered and pressurized diesel fuel to the diesel engine. It consists of a fuel tank with removable fuel fill strainer, fuel lines, fuel filter, fuel injection pump, and a fuel injector.

The diesel fuel is stored in a fuel tank. The tank features a plastic mesh strainer in the fill neck opening and a fuel tank drain valve. The fuel tank supplies fuel via a flexible tube to the fuel filter. The fuel filter removes impurities and water from the diesel fuel before it reaches the diesel engine. The fuel filter is made up of a clear bowl and filter head with a throw-away paper filter. The fuel filter also includes a fuel shutoff valve and two bleed screws for removing air trapped in the fuel system. Another flexible tube connects the fuel filter and the fuel injection pump (part of the diesel engine).

With the engine cranking or running, the fuel flow is controlled by a mechanical governor (part of the diesel engine) and the fuel injection pump. The fuel injection pump pressurizes the fuel and transfers it to the fuel injector (part of the diesel engine). Fuel is sprayed by the injector into the engine combustion chamber where it is mixed with air and ignited. The fuel that is not burned by the engine is returned to the generator set fuel tank via an excess fuel return line.

The diesel engine is shut down by depressing the engine STOP lever which places the fuel injection pump control back in the no fuel position.

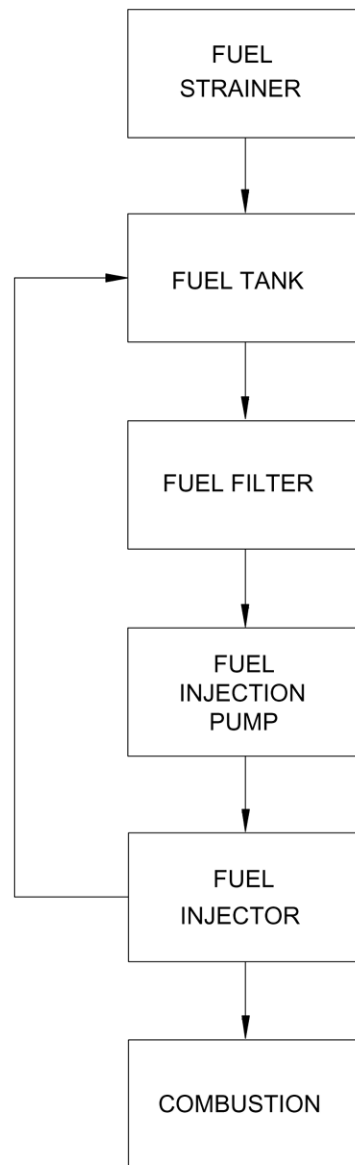

Figure 1. Generator Set Fuel System.

ENGINE AIR INTAKE AND EXHAUST SYSTEM

The Engine Air Intake and Exhaust System (Figure 2) provides filtered air to the diesel engine and an outlet for exhaust gas produced by air/diesel fuel combustion. The system consists of an air intake filter, air intake manifold, exhaust manifold, and muffler with spark arrester.

The air intake cleaner features a foam pre-filter and a disposable paper filter element. Air is drawn through the pre-filter and the filter element. Airborne dirt is trapped in the pre-filter and air intake filter element. Filtered air passes through the filter, air intake manifold, and open intake valve into the engine combustion chamber where it mixes with pressurized diesel fuel and is combusted.

Immediately following combustion, hot gases are forced out of the combustion chamber (through the open exhaust valve), and into the exhaust manifold. The exhaust manifold passes the gases into the muffler which deadens the sound created by the combustion process. The gases then pass through the muffler and out of the spark arrester which diffuses the gas. A muffler shroud and blanket (wrapped around the muffler), offer some protection to personnel who may inadvertently touch the muffler while the diesel engine is running.

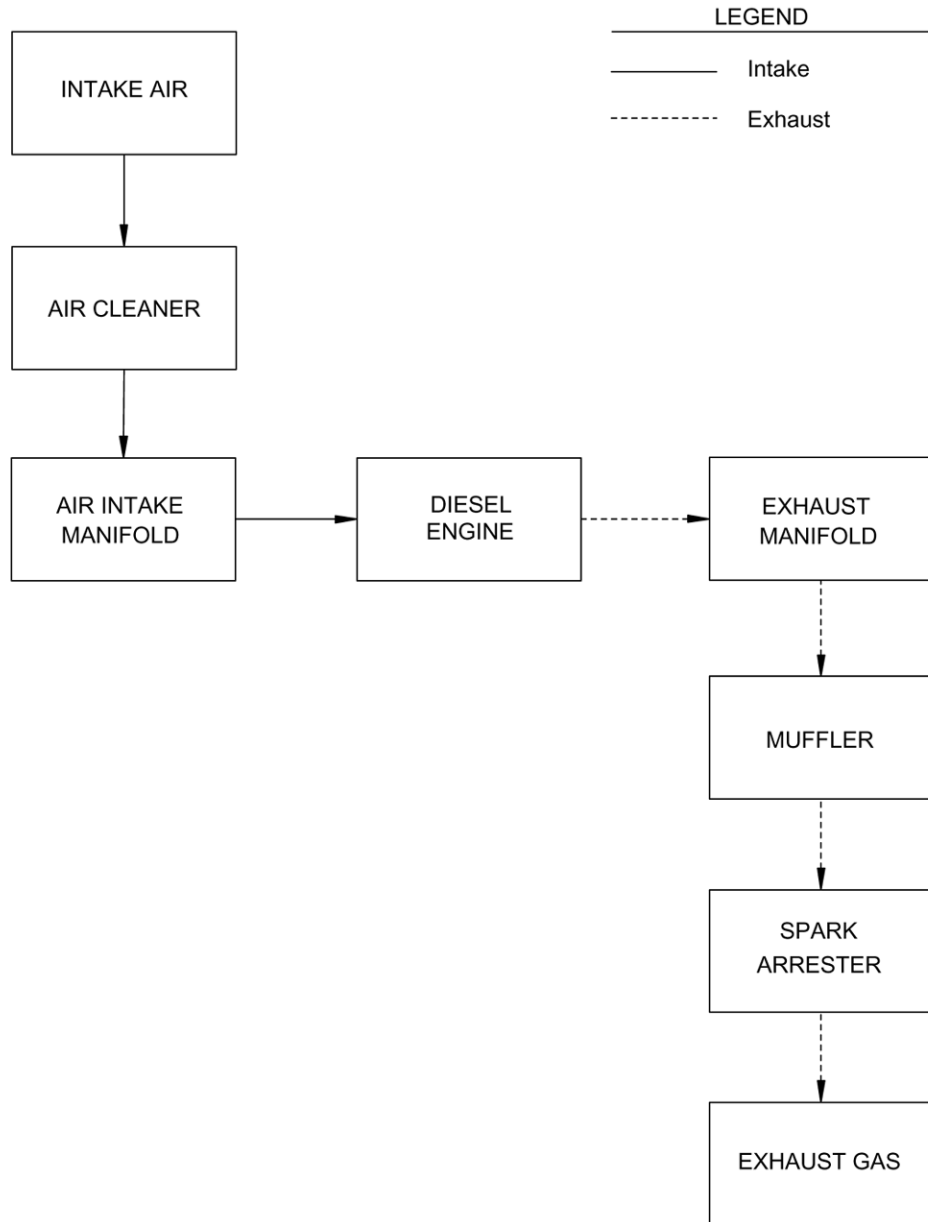

Figure 2. Engine Air Intake and Exhaust System.

SPEED CONTROL SYSTEM

Diesel engine speed is maintained by the speed control system (Figure 3) which includes the mechanical governor, governor lever, RUN lever, and STOP lever. The system is designed to maintain engine speed under load at a constant rate of between 3,570 and 3,630 rpm (no load speed of 3,750 rpm).

The governor is the flyweight-type, with the weights mounted on a gear driven by the engine camshaft gear. The force of the flyweights is transferred through a thrust sleeve and collar to the governor lever which is balanced against the tension of the governor spring. The spring is stretched between the governor lever and the engine RUN lever. When the engine speed drops below the governed speed, the resulting decrease in governor flyweight/camshaft rotation places tension on the governor spring. The tension repositions the fuel injection pump rack and increases the stroke of the plunger in the fuel injection pump allowing more fuel to flow to the pump delivery valve. The increase in fuel flow causes the diesel engine to speed up. As the diesel engine recovers to the governed speed, the governor flyweight/camshaft rotation stabilizes and the tension on the governor spring relaxes. This changes the position of the fuel injection pump rack and shortens the stroke of the plunger allowing less fuel to flow to the fuel injectors maintaining the engine speed at 3,600 RPM.

The governor control mechanism features two operator controlled levers. The black diesel engine RUN lever places tension on a spring attached to the governor lever. The tension places the governor lever in a position to allow fuel flow to the fuel injector for diesel engine start up and to allow the diesel engine to continue running after startup. The red diesel engine shut down or STOP lever is operated by either depressing the red STOP lever or by the low oil pressure shutdown system. When depressed, the lever trips the RUN lever releasing the tension on the governor spring which places the governor lever in a no fuel or stop position. This action shuts off fuel flow to the fuel injector stopping the combustion process and shutting down the diesel engine.

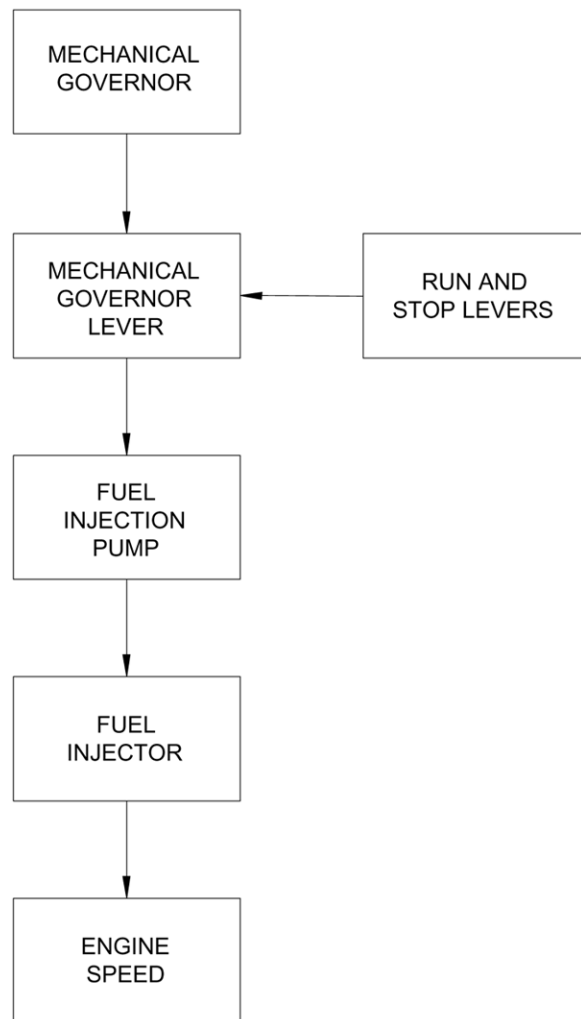

Figure 3. Diesel Engine Governor.

DIESEL ENGINE ELECTRICAL STARTING SYSTEM

Electrical Starting

The diesel engine electrical starting system (Figure 4) can be used to start the diesel engine whenever there is an external 24 VDC power source connected to the NATO slave receptacle. The electrical starting system will be required when starting the diesel engine in extremely cold weather or as a backup to the manual starting system (recoil mechanism failure). The electrical system also provides a means for warming diesel engine intake air which also helps to start the engine in cold weather. The system consists of a NATO slave receptacle (SR1), START-PREHEAT/PREHEAT/OFF/START switch (S2), diode (CR1), an engine-mounted starter motor (B1) with solenoid (L5), and two resistance heater elements (HTR1 and HTR2).

When connected to a 24 VDC power source via a power cable, the NATO slave receptacle (SR1) provides power to the START-PREHEAT/PREHEAT/OFF/START switch (S2) at pin B and to the starter solenoid (L5) at pin S. When the operator places switch (S2) in the START position, power is applied through the switch at pin S to the starter solenoid (L5) pin C. This energizes the coil in solenoid (L5) which pulls in the solenoid plunger and pushes the starter drive pinion attached to the plunger toward the engine flywheel. This movement engages the starter pinion drive with the ring gear teeth on the diesel engine flywheel. As the solenoid plunger pulls in, the power available at solenoid pin S is applied via a jumper to the starter motor (B1) which rotates the starter pinion drive (part of the starter motor) and turns over the flywheel engaged with the pinion drive to start the diesel engine. Immediately after the diesel engine starts, the generator set operator releases the START-PREHEAT/PREHEAT/OFF/START switch (S2). This opens the solenoid-starter circuit causing the solenoid plunger to release the starter pinion drive disengaging it from the engine flywheel ring gear. At the same time, the starter motor (B1) is de-energized. The starter pinion will return to its normal position as the starter motor (B1) slows to a stop.

Diode (CR1) protects the diesel engine electrical starting circuit. It prevents any inductive surges in the grounded side of the circuit from damaging the contacts of START-PREHEAT/PREHEAT/OFF/START switch (S2) and the starter solenoid (L5).

Preheat Circuit

The diesel engine features two 12-VDC resistance-type heaters (HTR1 and HTR2) wired in series and located in the engine air intake piping between the intake manifold and the air cleaner. The heaters warm the air intake piping and manifold in order to warm up the intake air during attempted cold weather starts.

With an external power cable connected to the NATO slave receptacle and the START-PREHEAT/PREHEAT/OFF/START switch (S2) in the PREHEAT position, power exiting switch S2 at pin H energizes the two resistance-type heaters (HTR1 and HTR2). Normally, the heaters are allowed to remain energized for several minutes to warm up the air intake piping and manifold in preparation for starting the engine. The heaters are then deenergized just prior to the engine startup sequence. However, during periods of extreme cold, it may be necessary to leave heaters HTR1 and HTR2 on during the start sequence. This is accomplished by placing switch S2 in the PREHEAT-START position so that heaters HTR1 and HTR2 remain energized during the engine startup sequence.

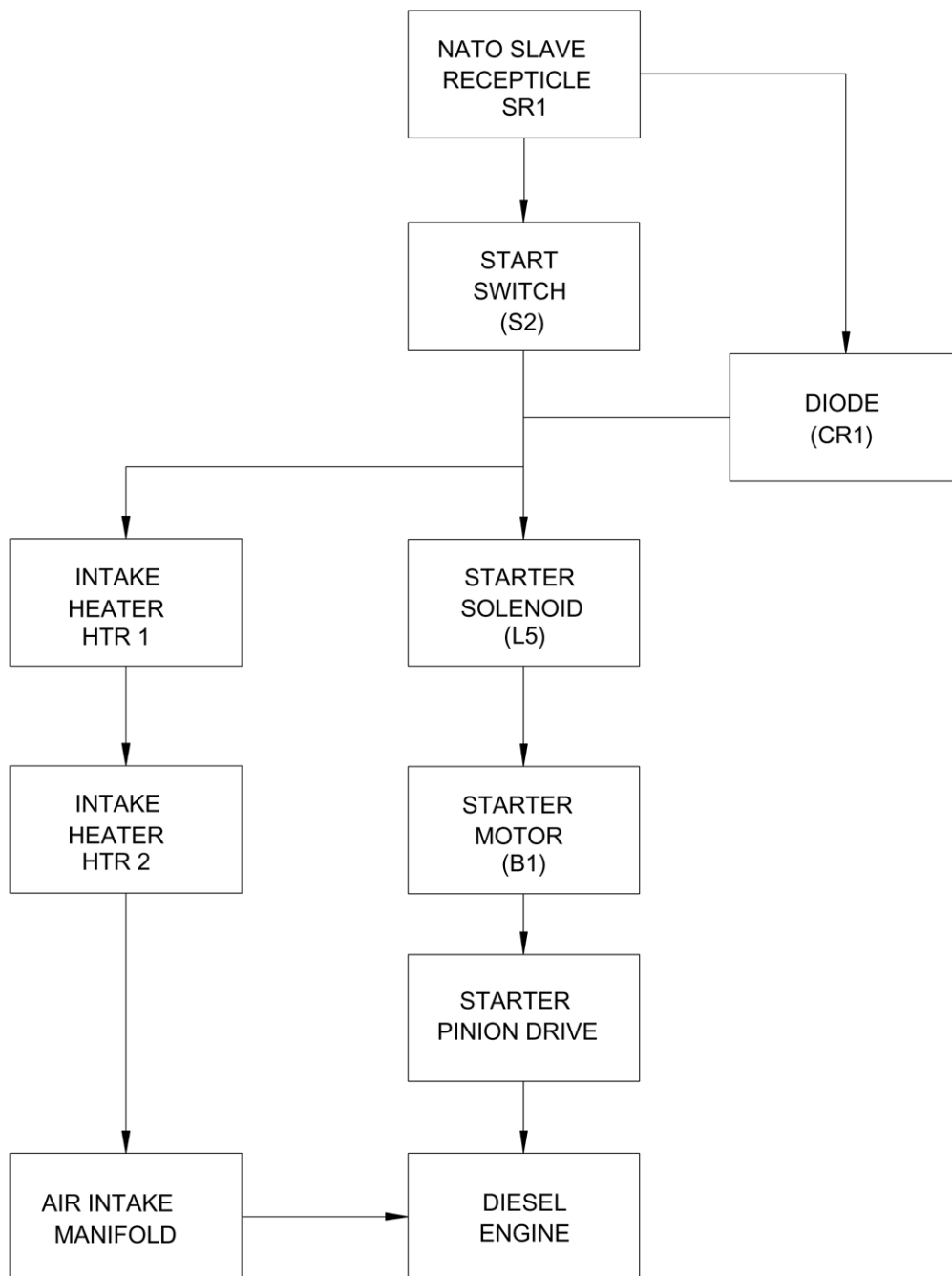

Figure 4. Diesel Engine Electrical Starting System.

GENERATOR VOLTAGE REGULATION AND OUTPUT SUPPLY (MEP-531A)

The generator voltage regulation and output supply system (Figures 5 and 6) senses the load being drawn at the load terminals and adjusts the alternator output accordingly. The system also monitors and adjusts generator set performance and provides power to a GFCI convenience receptacle.

The system consists of the AC alternator (G2), voltage regulator (A1), ON-OFF load circuit breaker (CB1), output load terminals (L and N), GFCI convenience receptacle (J3), AC VOLTS meter (M2), % LOAD meter (M1), HERTZ frequency meter (M4), VOLTAGE ADJ. potentiometer (R2), and fuse (F1). Power produced by the AC alternator is supplied to load terminals on the load terminal board and the GFCI convenience receptacle.

Voltage Regulation (Figure 5)

The generator set output voltage is controlled by the voltage regulator (A1). The voltage regulator continuously senses the alternator (G2) output voltage. The voltage regulator (A1) reacts to voltage variations by manipulating the alternator field current to maintain the output voltage. The field current controlled by the voltage regulator is supplied by the alternator excitation windings. The voltage regulator (A1) performs this function using three interactive sub circuits: power input, load sensing, and DC output. The power input circuit draws current from the AC generator (G2) exciter windings through the positive (+) field brushes at A1 pin 3. The load sensing circuit monitors the current being drawn by the load at A1 pin E1. As demand increases, the DC output circuit draws current from the power input circuit, rectifies it to direct current, and reapplies it to the AC alternator (G2) field via A1 pins F+ and F-.

Starting the diesel engine automatically field flashes the AC alternator (G2) with residual magnetism stored in the rotor. The residual magnetism induces voltage in the power excitation windings at AC alternator (G2) pins + and 2. As the diesel engine speed begins to increase toward its governed no load speed of 3750 rpm, the induced voltage in the power excitation windings increases. The voltage regulator (A1) power input circuit receives current from the power excitation windings via the positive (+) field brushes at A1 pin 3. Whenever the voltage in the load sensing circuit matches the set point, the current entering the voltage regulator (A1) at pin 3 is allowed to pass through the power input circuit. Whenever the voltage entering the sensing circuit is lower than the set point (indicating a load increase) the DC output circuit reacts by drawing current from the power input circuit. This current is rectified to DC and reapplied via A1 pins F+ and F- to the AC alternator rotor brushes at G2 pins + and -. The application of direct current to the rotor increases the field magnetism between the AC alternator stator and rotor which in turn, increases the current measured across the alternator power windings. The current measured at both the excitation and power windings will increase until the voltage entering the voltage regulator (A1) load sensing circuit matches the set point at which point, the alternator output stabilizes and the A1 DC output circuit stops drawing current from the power input circuit.

The voltage regulator (A1) set point can be changed by adjusting the VOLTAGE ADJ. potentiometer (R1). The set point can be changed from 114 to 126 VAC by loosening the locknut and turning the adjustment screw counterclockwise to lower the set point or clockwise to increase the set point. The set point adjustment can be checked with the diesel engine running by observing the needle on VOLTS AC meter (M2).

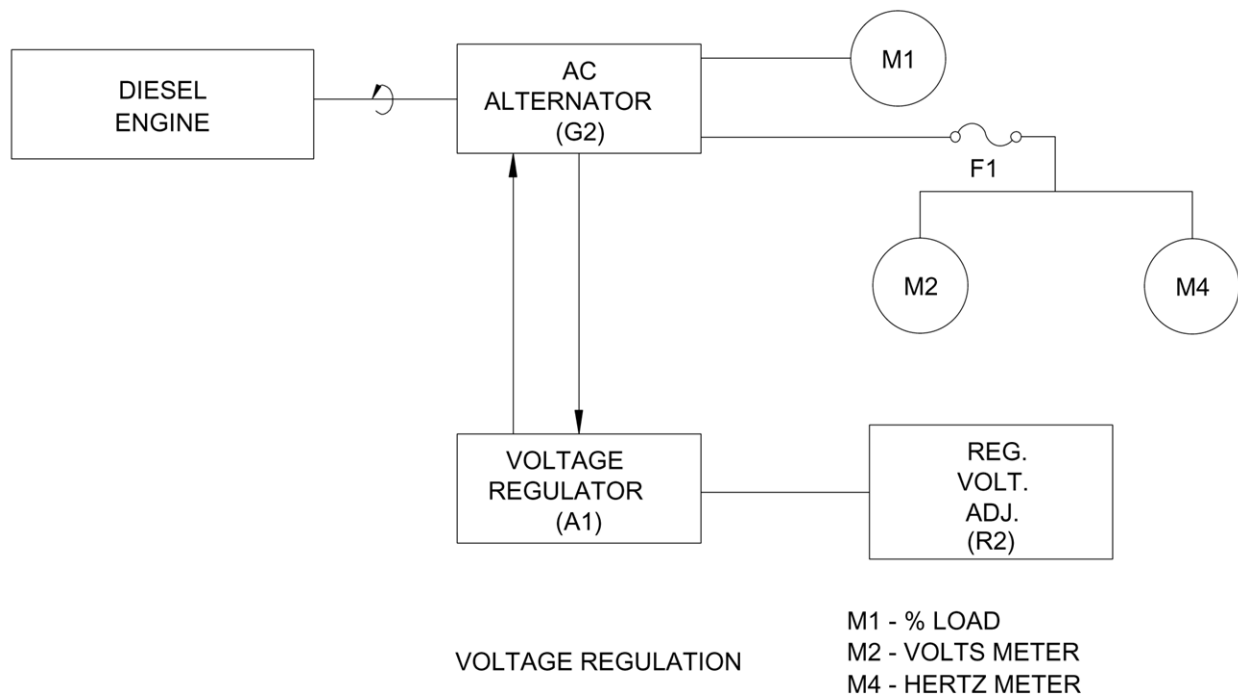

Figure 5. Generator Voltage Regulation System (MEP-531A).

The generator set performance can be monitored by observing the % LOAD meter (M1), VOLTS AC meter (M2), and HERTZ frequency meter (M4). The % LOAD meter (M1) measures the current being drawn by the load at the load terminals (L and N) and displays the value as a percent (0 to 125) of generator set capacity. The VOLTS AC meter (M2) measures the voltage across the power windings of the AC alternator (G2) and displays the value in VAC from 0 to 150. The HERTZ frequency meter (M4) measures frequency across the power windings in Hz from 55 to 65. Line fuse (F1) protects the VOLTS AC and HERTZ frequency meters from a potential over current condition.

Output Supply (Figure 6)

The generator set is brought on line by placing the ON-OFF load circuit breaker (CB1) in the ON position. The circuit breaker is a single pole, shunt trip switch with momentary contacts that return it to the neutral, or center position when the toggle switch is released. An Electromagnetic Interference (EMI) filter (MEP-531A) or load terminals L and N (Mechron 120 VAC set) are energized by this momentary contact to bring the generator set on line. The GFCI convenience receptacle (J3) is also energized by ON-OFF load circuit breaker (CB1). The GFCI convenience receptacle (J3) features a ground fault interrupter which protects the generator set components from inductive current in the ground circuit originating from the load connected to the GFCI receptacle (J3).

Placing the ON-OFF load circuit breaker (CB1) momentarily in the OFF position opens the line to the load terminals and takes the generator set off line. The ON-OFF load circuit breaker features a diode (CR2) which protects the generator set components by allowing current to flow in only one direction.

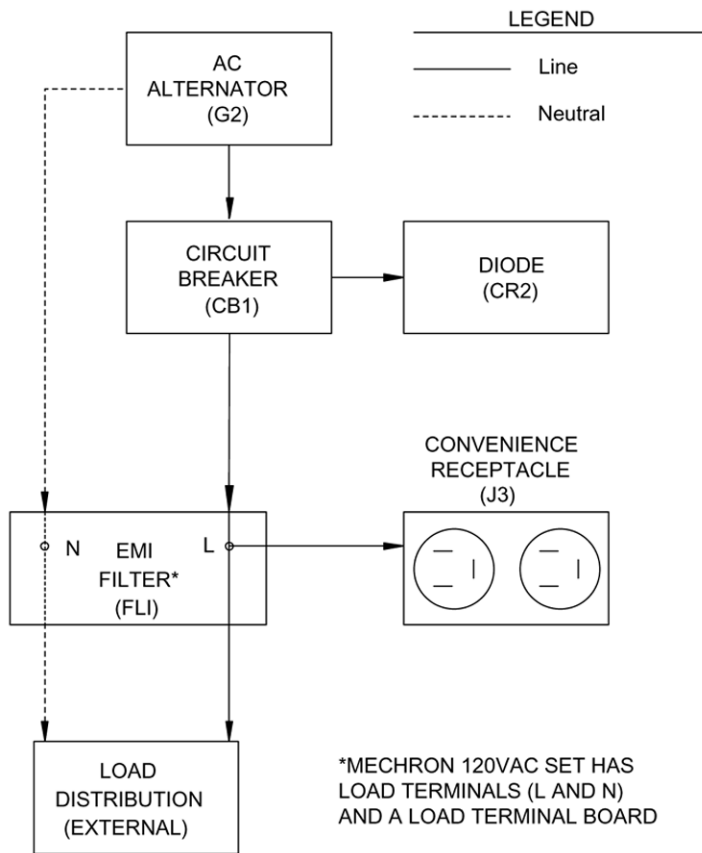

Figure 6. Generator Output Supply System (MEP-531A).

GENERATOR VOLTAGE REGULATION AND OUTPUT SUPPLY (MEP-501A)

The generator voltage regulation and output supply system (Figures 7 and 8) senses the load being drawn at the load terminals and adjusts the alternator output accordingly. The system also monitors and adjusts generator set performance.

The system consists of the alternator (G2), voltage regulator (A1), ON-OFF load circuit breaker (CB1), output load terminals (+ and -), DC VOLTS meter (M2), % LOAD meter (M1), and VOLTAGE ADJ. potentiometer (R2). Power produced by the alternator supplies load terminals on the load terminal board.

Voltage Regulation (Figure 7)

The generator set output voltage is controlled by the voltage regulator (A1). The voltage regulator continuously senses the alternator (G2) output voltage. The voltage regulator (A1) reacts to voltage variations by manipulating the alternator field current to maintain the output voltage. The field current controlled by the voltage regulator is supplied by the alternator excitation windings. The voltage regulator (A1) performs this function using three interactive sub circuits: power input, load sensing, and DC output. The power input circuit draws current from the generator (G2) exciter windings through the positive (+) field brushes at A1 pin F. The load sensing circuit monitors the current being drawn by the load across A1 pins S and A. As demand increases, the DC output circuit draws current from the power input circuit, rectifies it to direct current, and reapplies it to the AC alternator (G2) field via A1 pins F and L.

Starting the diesel engine provides the current necessary to field flash the alternator (G2). This current is supplied from the dynamo (G1) to the generator control unit (A2) where it is rectified to direct current. The direct current exits A2 at pin F and is applied to the alternator (G2) field windings. As soon as the generator control unit (A2) detects current at pin VINDC, it disables the flow of current exiting A2 at pin F.

The initial field flash current induces voltage in the power excitation windings at alternator (G2). As the diesel engine speed begins to increase toward its governed no load speed of 3750 rpm, the induced voltage in the power excitation windings increases. The voltage regulator (A1) power input circuit receives current from the power excitation windings via the positive (+) field brushes at A1 pin F. When the voltage in the load sensing matches the set point, the current entering the voltage regulator (A1) at pin F is allowed to pass through the power input circuit. When the voltage entering the sensing circuit is lower than the set point (indicating a load increase) the DC output circuit reacts by drawing current from the power input circuit. This current is rectified to DC and reapplied via A1 pins F and L to the alternator rotor brushes. The application of direct current to the rotor increases the field magnetism between the alternator stator and rotor which in turn, increases the current measured across the alternator power windings. The current measured at both the excitation and power windings will increase until the voltage entering the voltage regulator (A1) load sensing circuit at A1 pins S and A match the set point at which point, the alternator output stabilizes and the A1 DC output circuit stops drawing current from the alternator excitation windings.

The voltage regulator (A1) set point can be changed by adjusting the VOLTAGE ADJ. potentiometer (R1). The set point can be changed from 26.6 to 32.2 VDC by loosening the locknut and turning the adjustment screw counterclockwise to lower the set point or clockwise to increase the set point. The set point adjustment can be checked with the diesel engine running by observing the needle on VOLTS DC meter (M2).

The generator set performance can be monitored by observing the % LOAD meter (M1) and the VOLTS DC meter (M2). The % LOAD meter (M1) measures the current being drawn by the load at the load terminals (+ and -) and displays the value as a percent (0 to 125) of generator set capacity. The % LOAD meter (M1) operates on current provided by shunt resistor (R3). The VOLTS DC meter (M2) measures the voltage across the power windings of the alternator (G2) and displays the value in VDC from 0 to 40. Line fuse (F1) protects the VOLTS DC meter from a possible over current condition.

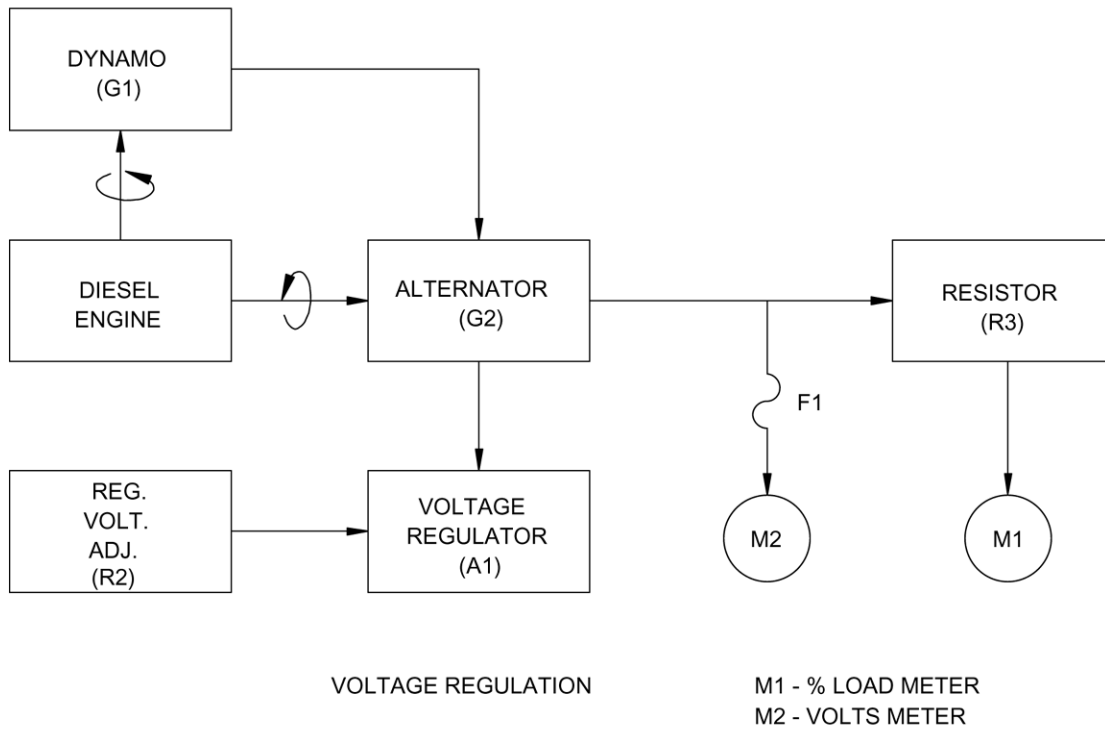

Figure 7. Generator Voltage Regulation System (MEP-501A).

Output Supply (Figure 8)

The generator set is brought on line by placing the ON-OFF load circuit breaker (CB1) in the ON position. The circuit breaker is a single pole, shunt trip switch with momentary contacts that return it to the neutral, or center position when the toggle switch is released. Load terminals L and N are energized by this momentary contact to bring the generator set on line.

Placing the ON-OFF load circuit breaker (CB1) momentarily in the OFF position opens the line to the load terminals and takes the generator set off line.

There is a transient suppression diode assembly consisting of two diodes (CR2 and CR3) at the load terminals (+ and -) on MEP-501A. These diodes protect the load circuit from potential damage resulting from cross connecting the + and - output terminals on the alternator (G2). The diodes prevent damage by only allowing the current to flow in the generator circuit in one direction.

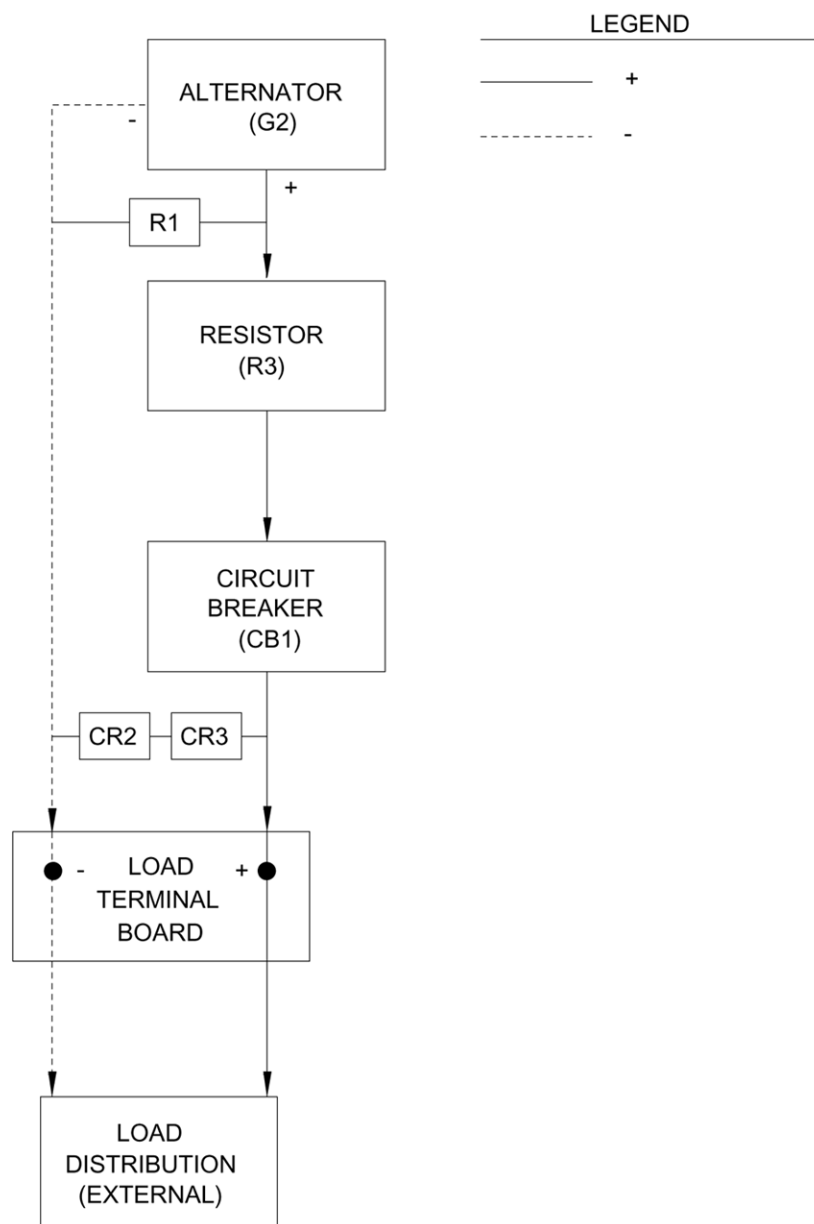

Figure 8. Generator Output Supply System (MEP-501A).

GENERATOR CONTROL CIRCUIT

The generator control circuit (Figure 9) consists of a dynamo (G1), the generator control unit (A2), discharge varistor (V1), HOURS meter (M3), and diode (CR2).

The dynamo (G1) generates power for the generator control circuit. The dynamo consists of a stator mounted to the diesel engine block and a dynamo wheel mounted to the engine flywheel. While the diesel engine is running, magnets mounted on the inside surface of the dynamo wheel provide the field magnetism necessary to generate current flow in the stator. The dynamo (G1) generates AC current which is connected via the engine wiring harness to the generator control unit (A2) at A2 pins VMAG1 and VMAG2.

The generator control unit (A2) rectifies the dynamo alternating current to direct current which exits at A2 pin VMAG+. This direct current is used to power the HOURS meter (M3), which maintains the cumulative time for generator set operation (e.g., the total time that the diesel engine dynamo generates power). The current is also used to energize the low oil pressure solenoid (L4) at L4 pin Y.

The generator control unit (A2) also detects a short circuit fault condition and trips the load circuit breaker (CB1). Under normal operating conditions, rectified DC current exits A2 at pin VMAG+ and provides current to the load circuit breaker (CB1) trip coil via an auxiliary shunt (part of CB1). Whenever CB1 is closed (connecting the generator set with the load), the auxiliary shunt closes enabling current to flow to the trip coil. The trip coil will not energize however since the circuit terminates at the generator control unit (A2) pin STC which is not grounded. While the generator set is operating, generator control unit (A2) continually monitors the current flow at A2 pin VINAC (or VINDC for MEP-501A). When a short circuit occurs (or when the generator set is shut down), the input at VINAC (or VINDC) drops or goes low. The generator control unit (A2) reacts by grounding the CB1 trip coil circuit at A2 pin STC. When the coil is energized, it opens the load circuit breaker (CB1) to isolate the generator set from the load.

Discharge varistor (V1) is connected across the dynamo wires leading to generator control unit (A2) pins VMAG1 and VMAG2. It protects the generator control unit (A2) from inductive voltage surges generated by the dynamo. It accomplishes this by limiting the peak discharge voltage to a safe value.

Diode (CR2), in MEP-531A, protects generator control unit (A2) by suppressing any spikes generated by the trip coil in circuit breaker (CB1).

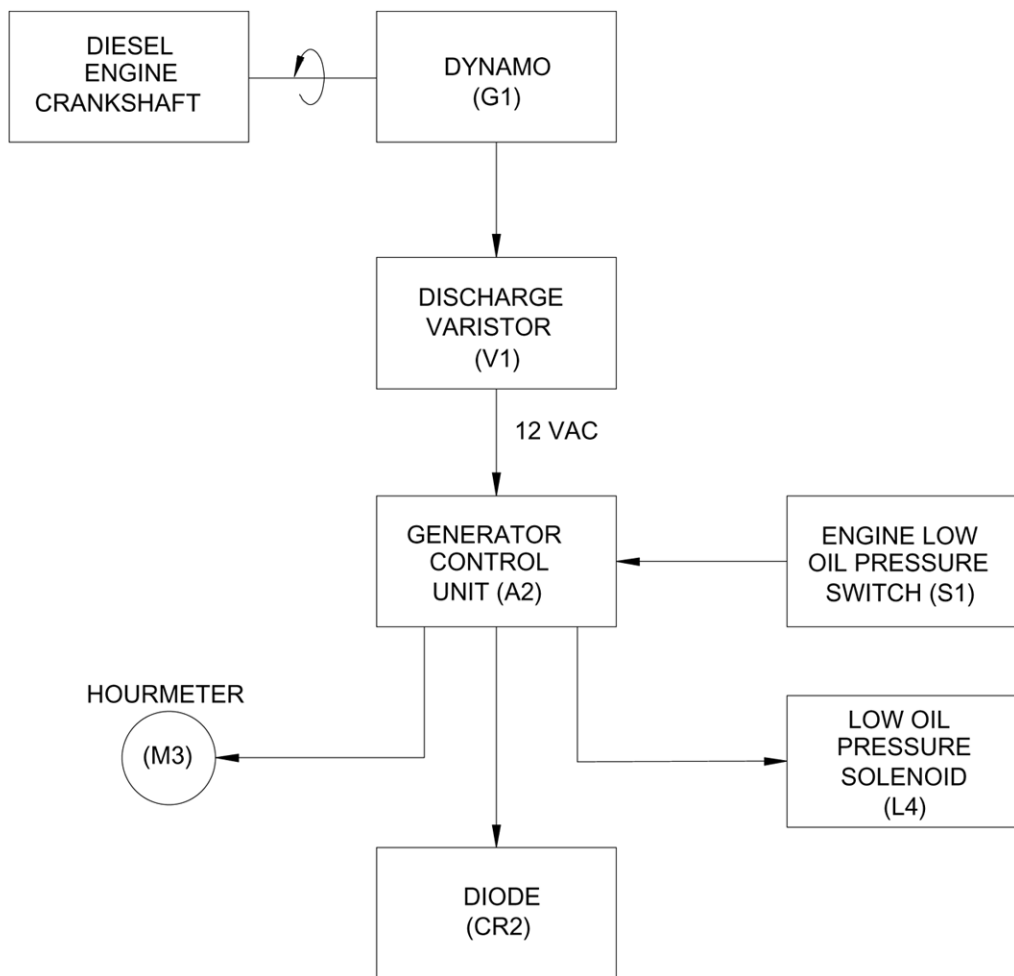

Figure 9. Generator Control Circuit.

LOW OIL PRESSURE PROTECTION

The low oil pressure protection system (Figure 10) shuts down the diesel engine in the event of low oil pressure in order to protect the engine from further damage. The system consists of a low oil pressure switch (S1) located in the engine block above the oil strainer, a low oil pressure solenoid (L4) mounted in the control panel, and a cable connecting the low oil pressure solenoid to the diesel engine STOP lever.

The generator control unit (A2) rectifies the alternating current supplied by the dynamo (G1) and provides direct current via A2 pin VMAG+ to the low oil pressure solenoid (L4) at pin Y. The circuit is completed at A2 pin LOP SOL which, after a short time delay, is allowed to pass through and exit A2 at pin LOP SW.

Under normal startup conditions, the low oil pressure switch (S1) opens at 12 to 18 psi (82.7 to 124.1 kPa) and stays open as long as the engine oil pressure stays above 15 psi (103.4 kPa). If a malfunction occurs in the lubrication system causing the oil pressure to drop below the low oil pressure set point, the low oil pressure switch (S1) closes. The low oil pressure solenoid (L4) circuit terminating at A2 pin LOP SW becomes grounded when S1 closes. This energizes the low oil pressure solenoid (L4) coil which momentarily pulls-in the solenoid' s plunger. The plunger is connected by a push-pull cable to the engine STOP lever. The cable trips the engine STOP lever placing the governor control lever and the fuel injection pump rack in the "no fuel" position to cut off fuel to the diesel engine to shut down the generator set.

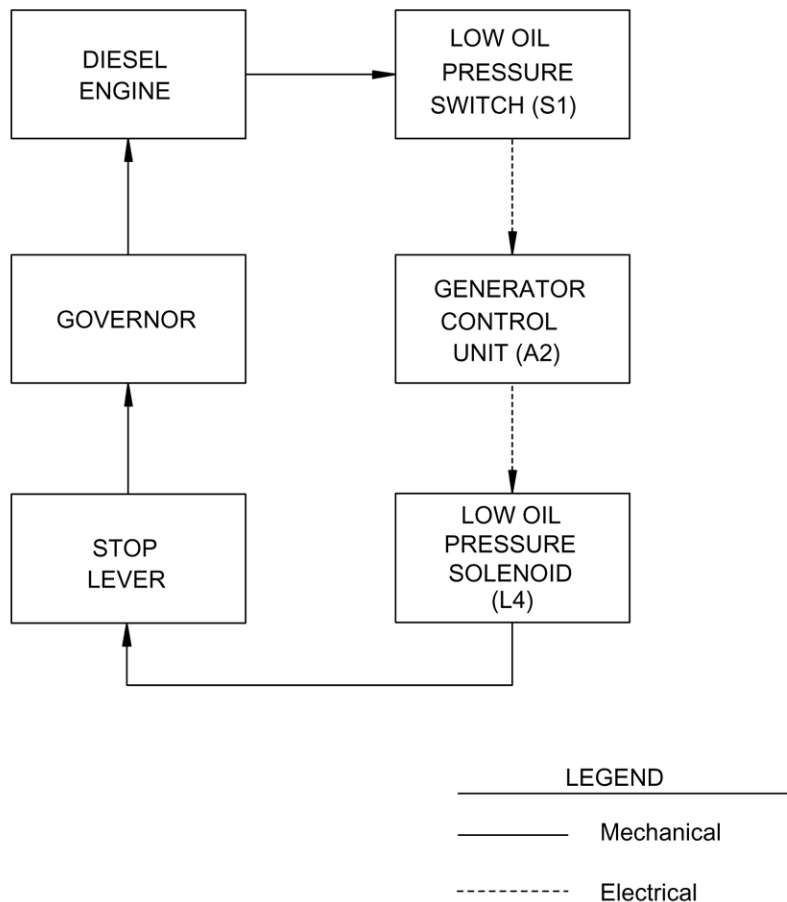

Figure 10. Low Engine Oil Pressure Protection System.

END OF WORK PACKAGE

CHAPTER 2
OPERATOR INSTRUCTIONS
FOR
2 kW MILITARY TACTICAL GENERATOR SETS
MEP-531A
MEP-501A

CHAPTER 2
OPERATOR INSTRUCTIONS

WORK PACKAGE INDEX

<u>Title</u>	<u>WP Sequence No.</u>
Description and Use of Operator Controls and Indicators	0004
Operation Under Usual Conditions.....	0005
Operation Under Unusual Conditions.....	0006

OPERATOR MAINTENANCE

**2 kW MEP-501A/531A MILITARY TACTICAL GENERATOR SETS
DESCRIPTION AND USE OF OPERATOR CONTROLS AND INDICATORS**

SCOPE

This work package describes operator controls and indicators for the generator set.

CONTROLS AND INDICATORS

The operator controls and indicators are identified in Figure 1 and Table 1.

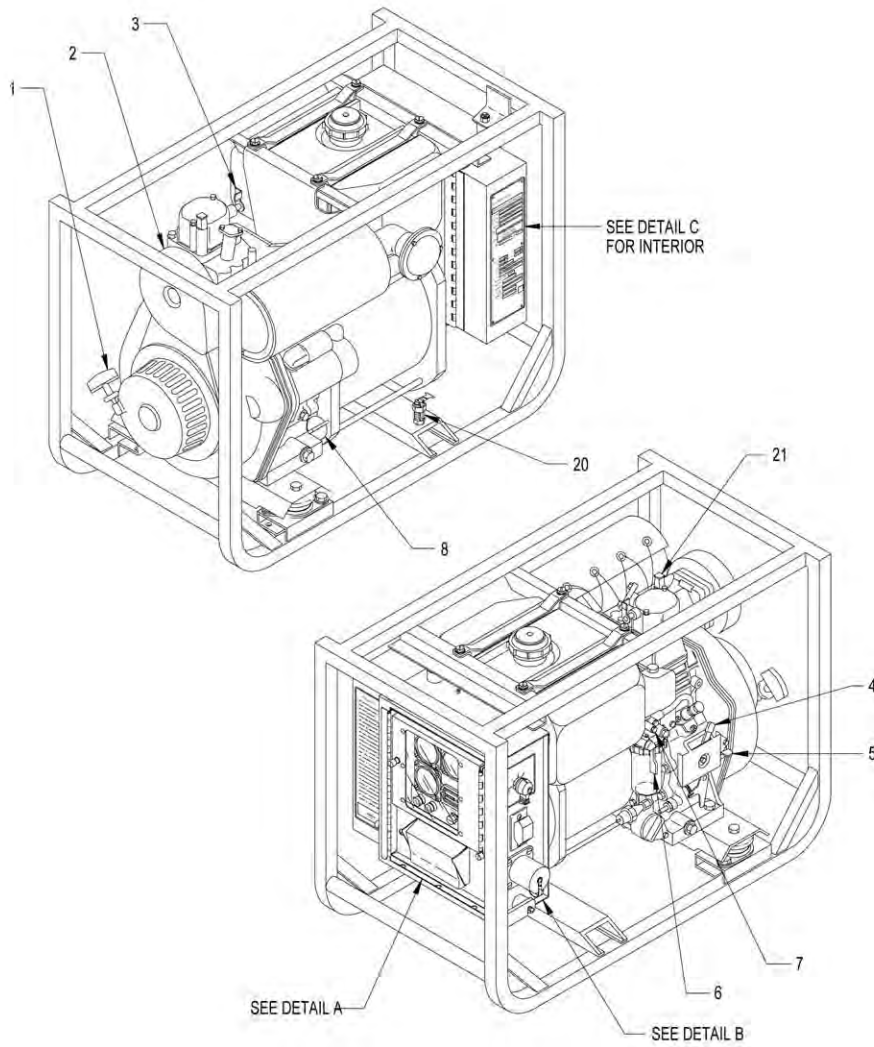
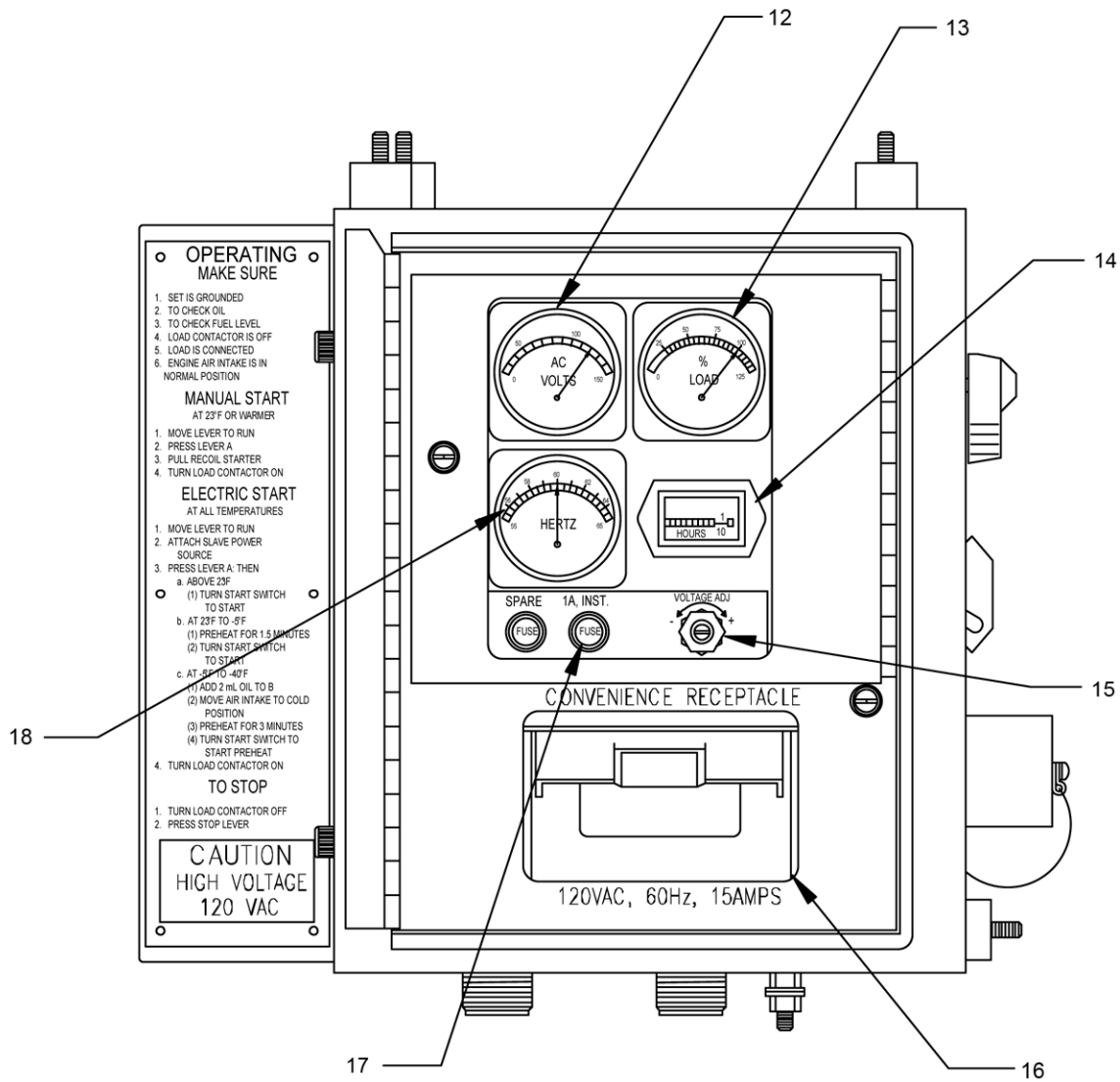
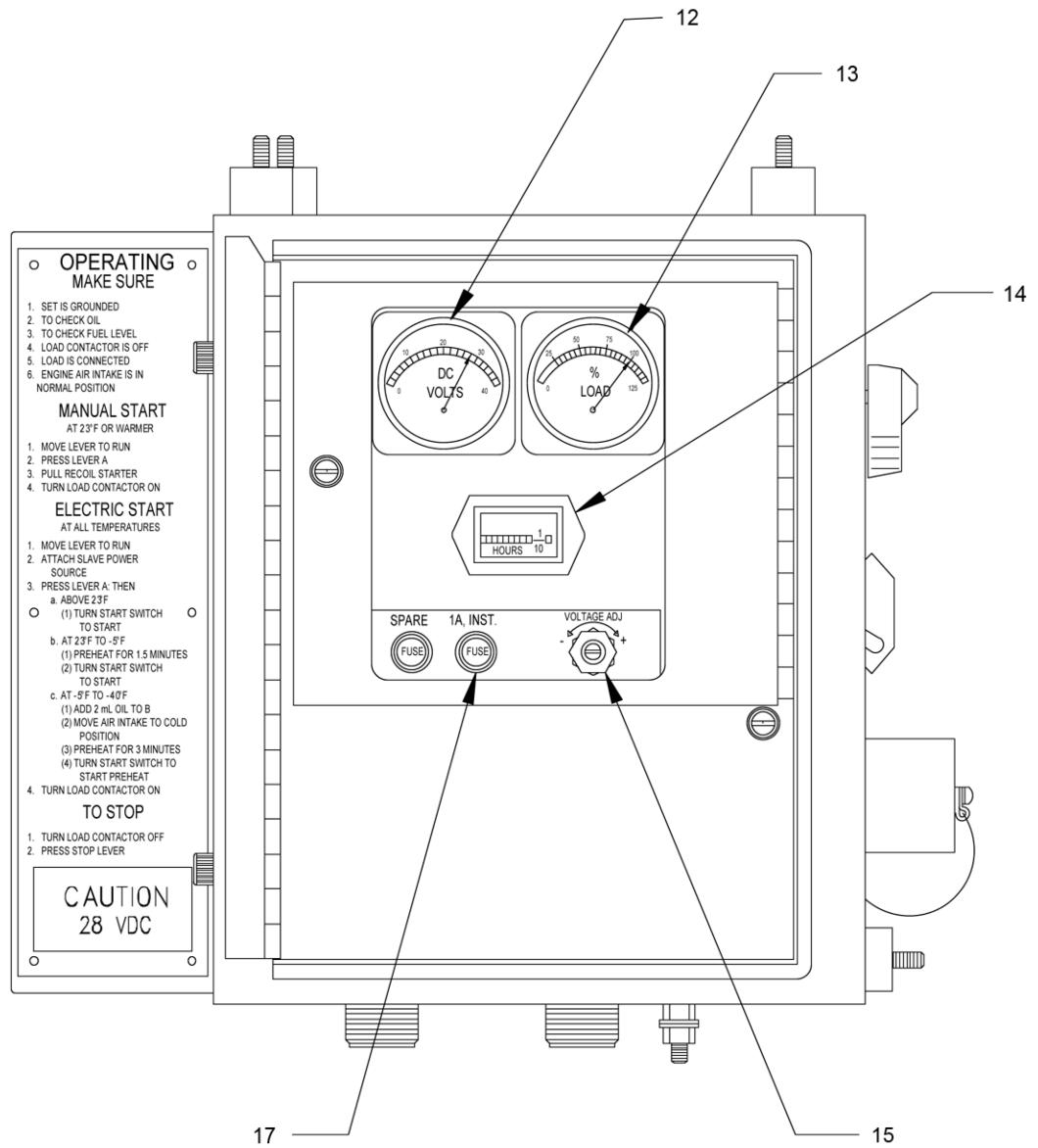

Figure 1. Operator Controls and Indicators (Sheet 1 of 4).



DETAIL A
MEP-531A

Figure 1. Operator Controls and Indicators (Sheet 2 of 4).



DETAIL A
MEP-501A

Figure 1. Operator Controls and Indicators (Sheet 3 of 4).

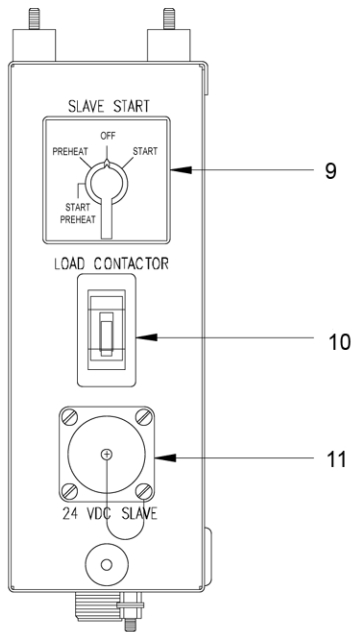

DETAIL B
MEP-531A

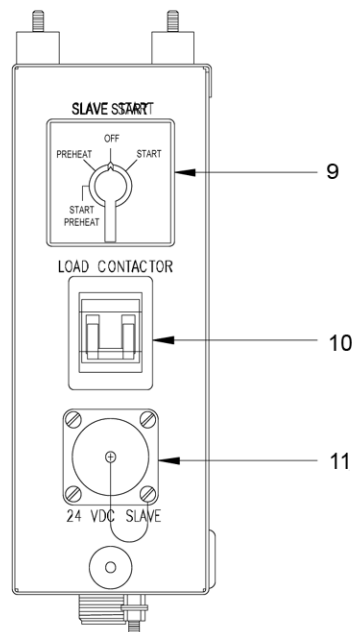

DETAIL B
MEP-501A

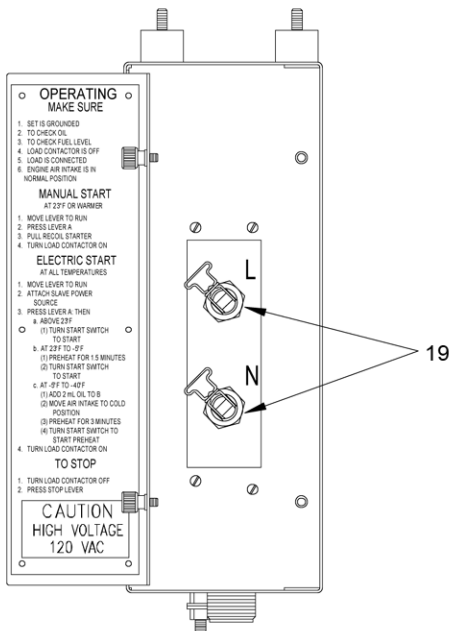

DETAIL C
MEP-531A

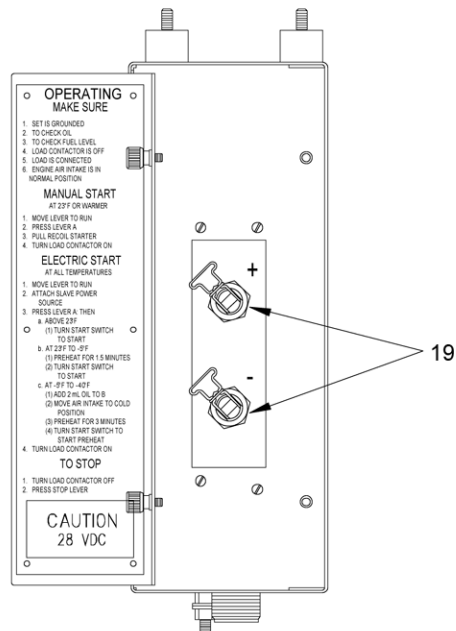

DETAIL C
MEP-501A

Figure 1. Operator Controls and Indicators (Sheet 4 of 4).

Table 1. Operator Controls and Indicators.

Key	Control/Indicator	Function
1.	Recoil Starter	When pulled, turns-over engine flywheel/crankshaft to start diesel engine.
2.	Air Intake Cover	Directs airflow into the engine air intake system. In cold weather, the cover is positioned to allow air which has been warmed by the hot muffler to flow into diesel engine air intake system. Normally, the cover is positioned to allow ambient air to flow into the diesel engine.
3.	Decompression Lever "A"	When depressed, releases compression in the diesel engine combustion chamber to allow for manually pull starting the engine. Lever automatically returns to its up ("off") position when recoil starter is pulled.
4.	RUN Lever (Black)	Pushed - Enables fuel flow to diesel engine fuel injection pump for starting and running generator set.
5.	STOP Lever (Red)	Depressed - Disables fuel flow to diesel engine fuel injection pump to stop engine.
6.	Fuel Shutoff Valve	↓O (Open) - Allows fuel to flow from fuel filter to diesel engine fuel injection pump. ↑C (Closed) - Shuts off fuel flow from fuel filter to fuel injection pump.
7.	Fuel Filter Bleed Screws (2 ea)	Bleed air from the generator set fuel system.
8.	Oil Fill Cap/Dipstick	Check and add lubrication oil to diesel engine (one on each side of engine).
9.	START-PREHEAT/ PREHEAT/OFF/ START Rotary Switch	START-PREHEAT - Selected and held, energizes 24-VDC starting circuit and air intake heaters when 24 VDC power is connected to NATO slave receptacle. When released, spring loaded switch returns to OFF position. PREHEAT - Selected and held, energizes air intake heaters mounted between air cleaner and diesel engine air intake manifold when 24 VDC power is connected to NATO slave receptacle. When released, spring loaded switch returns to OFF position. OFF - Disables diesel engine 24 VDC starting circuit. START - Selected and held, energizes 24 VDC diesel engine starting circuit when 24 VDC power is connected to NATO slave receptacle. When released, spring-loaded switch returns to OFF position.
10.	ON-OFF Load Circuit Breaker	ON - Closes AC circuit to supply power to load terminals. OFF - Opens AC circuit to shut off power to load terminals.
11.	NATO Slave Receptacle	Supplies power to diesel engine start and air intake heater circuits when connected to external 24 VDC power source via a NATO power cable.
12.	VOLTS Meter (AC MEP-531A) (DC MEP-501A)	Indicates output voltage of generator set. Normal reading for MEP-531A is 120 VAC and for MEP-501A is 28 VDC.
13.	% LOAD Meter	Indicates generator set load current as a percent of its rated current. Normal reading is dependent on load demand from 0 to 125 percent.
14.	HOURS Meter	Indicates total diesel engine operating hours.
15.	VOLTAGE ADJ. Potentiometer	Adjusts generator set voltage from 114 V to 126 VAC (MEP-531A) or from 26.6 to 32.2 VDC (MEP-501A).

Table 1. Operator Controls and Indicators. - Continued

Key	Control/Indicator	Function
16.	GFCI Receptacle (MEP-531A only)	Provides 15 Amp, 120 VAC power. Receptacle features a Ground Fault Circuit Interrupter (GFCI), which protects the generator set from power surges originating from powered equipment and two grounded convenience receptacles. PRESS TO TEST pushbutton tests the GFCI feature of the receptacle. PRESS TO RESET pushbutton resets the GFCI breaker.
17.	INST. Fuse	Protects the voltmeter (VOLTS) and frequency (HERTZ) meter during an over current condition. A spare fuse is contained in a fuse holder to left of primary fuse.
18.	HERTZ Frequency Meter (MEP-531A only)	Indicates generator set output frequency. This meter may also be used to determine the engine rpm by multiplying the reading by 60 (e.g. 60 Hertz x 60 = 3,600 rpm). Normal reading is 60 Hz.
19.	Electromagnetic Interference (EMI) Filter (MEP-531A) Load Terminals (MEP-501A and Mechtron Sets)	Provide connection point for load cables. Load terminals "L" and "N" (MEP-531A) and "+" and "-" (MEP-501A) are split lug connectors for ease in connecting load cables.
20.	Ground Stud	Provides location for grounding generator set to suitable ground.
21.	Rubber Plug	Cold Weather Start, Engine Preservation

END OF WORK PACKAGE

OPERATOR MAINTENANCE**2 kW MEP-501A/531A MILITARY TACTICAL GENERATOR SETS****OPERATION UNDER USUAL CONDITIONS**

INITIAL SETUP:**Tools and Special Tools**

Tool Kit, General Mechanic's Automotive or
Standard Automotive Tool Set
(WP 0159, Table 2, Item 6)

Materials/Parts

Grounding Equipment

Personnel Required

91D

References

WP 0004, Description and Use of Operator Controls
and Indicators
WP 0007, Operator Troubleshooting Index
WP 0010, PMCS Including Lubrication Instructions

Equipment Condition

Generator set shut down (Stopping Procedure)
Cable disconnected for NATO Slave Receptacle

GENERAL

This work package provides information and guidance for generator set operation under normal conditions. Refer to FM 5-424, Theory of Operations Electrical Systems.

ASSEMBLY AND PREPARATION FOR USE**Installation of Ground Rods****WARNING**

Never attempt to start the generator set if it is not properly grounded. Failure to observe this warning could result in serious injury or death by electrocution.

1. Insert ground cable (6 AWG min.) through slot on frame mounted terminal stud GND (see Figure 1). Hold terminal body hex with one wrench and tighten terminal nut on terminal stud.
2. Drive an eight-foot (or longer) ground rod into ground until clamp on top of ground rod is just above surface.
3. Insert ground cable through ground rod clamp and tighten clamp screw.

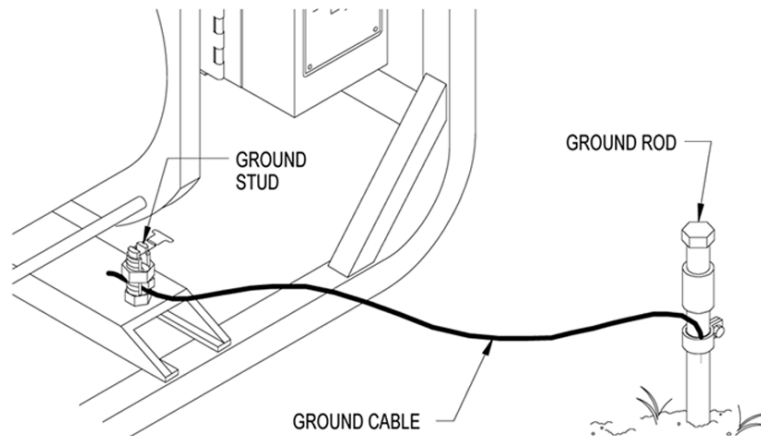

Figure 1. Grounding Connections (Typical Installation).

END OF TASK

Installation of Load Cables

WARNING

Never attempt to connect or disconnect load cables while the generator set is running. Failure to observe this warning could result in severe personal injury or death by electrocution.

1. If operating, shut down generator set and open load terminal board cover.
2. Using suitable wrenches, hold terminal body hex with one wrench and loosen terminal nuts (Figure 2) on terminals "L" and "N" (MEP-531A) or "+" and "-" (MEP-501A).
3. Insert ends of load cables through load cable exit. Then insert ends of cables into slots of load terminal studs.
4. Hold terminal body hex with one wrench and tighten load terminal nuts and lock retaining clips. Then close and secure load terminal board cover.

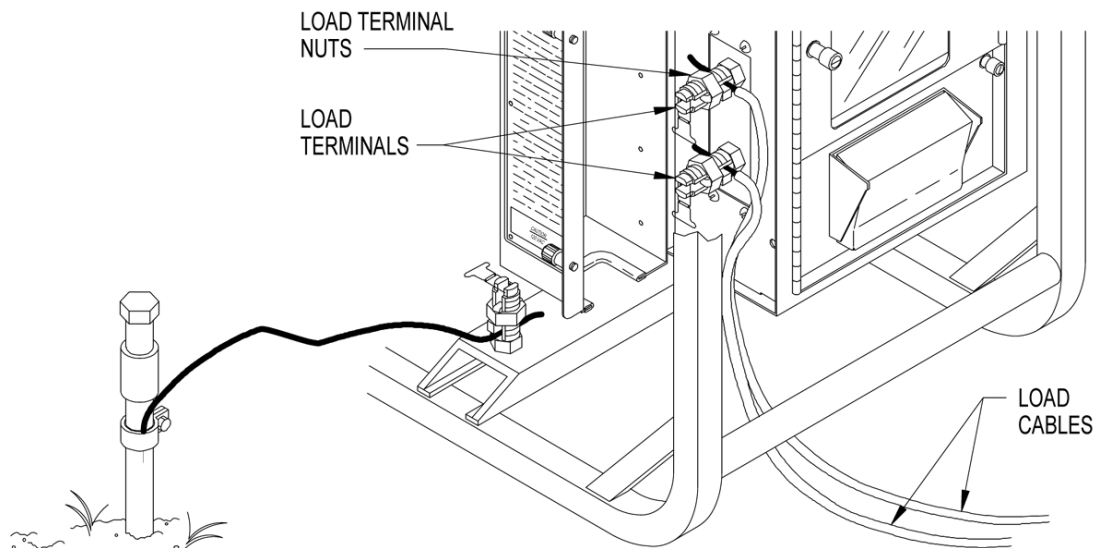

Figure 2. Installation of Load Cables.

END OF TASK

Priming and Bleeding the Fuel System

WARNING

The fuels in this generator set are flammable. Do not smoke or use open flames when performing maintenance. Do not service or drain the fuel system while open flames are present. Flames and explosion could result in severe personal injury or death. Use a container or cloth to catch any excess fuel to prevent spilling over engine components. Be sure to properly dispose of diesel fuel and diesel fuel soaked cloths.

WARNING

Hot fueling of generator sets while they are operating presents a safety hazard and should not be attempted. Hot engine surfaces and sparks produced from the engine and generator circuitry are possible sources of ignition. Failure to observe this warning could result in severe personal injury or death.

Under normal conditions, the fuel system does not require priming. Certain conditions may allow air into the fuel system, for example, running out of fuel. Once this occurs, the air must be bled before the engine will start or run smoothly. Using Figure 3, proceed as follows:

1. Check that fuel tank has fuel and that fuel shutoff valve (Figure 3) located on the filter is positioned to ↓O (open).
2. Open two bleed screws (Figure 3) at top of filter in the order listed below.
 - a. Open left bleed screw to bleed air from tank-to-filter fuel line.
 - b. Open right bleed screw to bleed air from filter to pump fuel line. It may be necessary to squeeze line by hand to force air out of bleed screw.
3. When fuel flows freely and evenly out of bleed screws (without air bubbles), tighten both bleed screws.
4. Loosen output fuel line fitting at fuel injection pump, place engine RUN lever to RUN position, depress and hold decompression lever, and pull recoil starter rope until fuel flows from around fuel line fitting (without air bubbles). Tighten output fuel line.

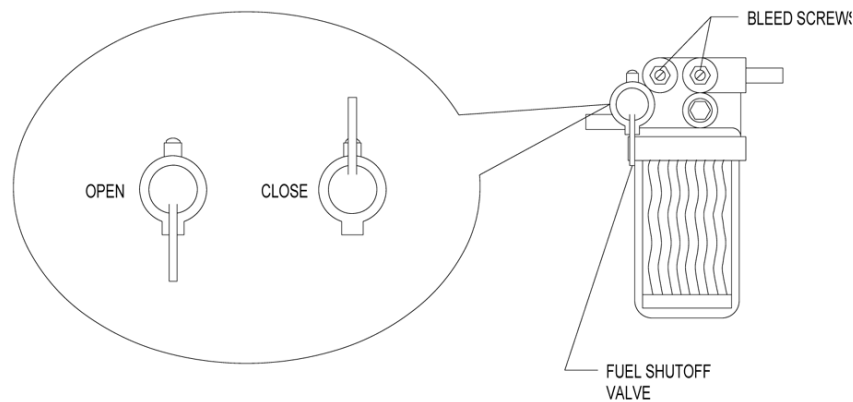

Figure 3. Fuel Filter Bleed Screws.

END OF TASK

INITIAL ADJUSTMENTS, BEFORE USE AND SELF-TEST

The diesel engine must be broken in, avoiding heavy loads (no greater than 75%), for a period of at least twenty (20) hours to ensure proper operation of the generator set. After the initial break-in period, intake and exhaust valve clearances must be checked and adjusted, the head nuts torque must be checked, and engine lubricating oil changed. Contact field maintenance.

END OF TASK

OPERATING PROCEDURES

WARNING

High voltage is produced when this generator set is in operation. Use care when working around an open control panel with the generator set operating. Improper operation and/or failure to follow this warning could result in personal injury or death by electrocution.

WARNING

Exhaust discharge contains deadly gases. Do not operate generator set in enclosed area unless exhaust discharge is properly vented outside. Position as far away from personnel, shelters, and occupied vehicles as possible. Failure to observe this warning could result in severe personal injury or death due to carbon monoxide poisoning.

WARNING

The noise level of this generator set when operating could cause hearing damage. Hearing protective devices must be worn when operating or working within 13 feet of the generator set when it is running. Failure to observe this warning can result in personal injury.

WARNING

Hot fueling of generator sets while they are operating presents a safety hazard and should not be attempted. Hot engine surfaces and sparks produced from the engine and generator circuitry are possible sources of ignition. Failure to observe this warning could result in severe personal injury or death.

WARNING

High fuel pressure is generated as a result of operation of the generator set. High-pressure leaks could cause severe personal injury or death.

CAUTION

If the diesel engine starts racing (overspeeding) at startup or during operation, there is a governor control malfunction. Depress the engine STOP lever immediately to avoid possible damage to the diesel engine caused by excessive overspeeding.

CAUTION

Check stenciled or painted markings on air intake cover to ensure it is in the proper position. Normal position of cover allows ambient temperature air to flow into the diesel engine. Failure to place air intake cover in normal position, except in temperatures below -5 °F, may cause engine oil breakdown, engine overheating, or catastrophic engine failure.

NOTE

Under normal operating conditions, generator set will vibrate "walk" on hard surfaces. Block generator set appropriately.

Manual Starting [23 °F (-5 °C) to 122 °F (50 °C)]**WARNING**

Never attempt to start the generator set if it is not properly grounded. Failure to observe this warning could result in serious injury or death by electrocution.

1. Ground generator set. Refer to Installation of Ground Rods.
2. Switch ON-OFF load circuit breaker (WP 0004, Figure 1, Item 10) to OFF

WARNING

Never attempt to connect or disconnect load cables while the generator set is running. Failure to observe this warning could result in severe personal injury or death by electrocution.

3. Connect load cables to load terminals. Refer to Installation of Load Cables.
4. Perform all B (Before) PMCS procedures. Refer to WP 0010, Table 1.
5. Check that air intake cover (2) is in NORMAL operating (summer) position as indicated on top of filter cover (Figure 4).
6. Ensure that fuel shutoff valve (WP 0004, Figure 1, Item 6) is in the ↓O (open) position.
7. Pull recoil starter (1) slowly. Stop when it feels tight.
8. Depress decompression lever "A" (3).
9. Move engine RUN lever (4) to RUN position (Figure 5).

CAUTION

A condition known as reverse rotation can occur if the recoil starter rope is pulled out too slowly. If the engine rotation reverses, you will hear abnormal noises caused by the reverse rotation of the oil pump. **DEPRESS THE ENGINE STOP LEVER IMMEDIATELY.** Failure to do so will cause the engine bearings to seize due to lack of lubrication.

10. Take up the slack in recoil starter rope (1) and pull rope quickly and all the way out.
11. If the engine fails to start, repeat Steps 7 through 10.
12. If engine still fails to start after two attempts. Refer to operator troubleshooting index in WP 0007.

13. Check all gauges for proper indications as follows, refer to WP 0004, Figure 1:

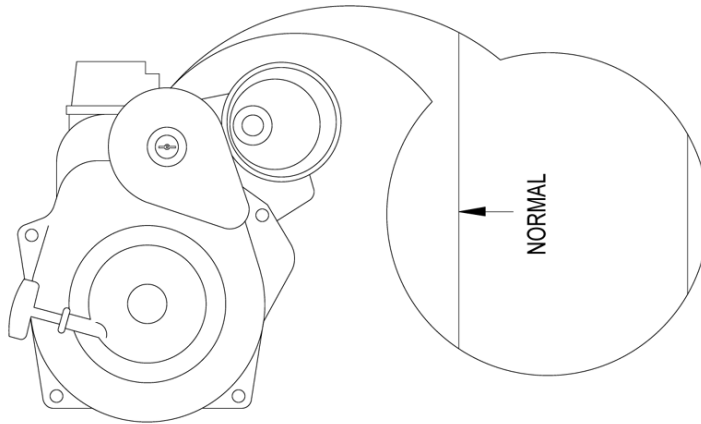

Figure 4. Air Intake Cover, Normal Operation.

NOTE

If any gauge indicates an improper value, refer to the operator troubleshooting index in WP 0007.

- VOLTS AC meter (12) for 120 VAC (MEP-531A) or VOLTS DC meter (12) for 28 VDC (MEP-501A).
- HERTZ frequency meter (18) for 60-63 Hz (MEP-531A).
- % LOAD meter (13) under no load condition should read 0 (%). The reading will vary as the demand changes (from 0 to 125%).

NOTE

Under normal conditions, allow the diesel engine to warm-up for five minutes before applying a load. If necessary, the load can be applied immediately.

- Switch ON-OFF load circuit breaker (WP 0004, Figure 1, Item 10) to ON to apply load.
- Perform all D (During) PMCS procedures in accordance with WP 0010, Table 1.

END OF TASK

Electric Starting [23 °F (-5 °C) to 122 °F (50 °C)]

- Ground generator set, refer to Installation of Ground Rods.
- Switch ON-OFF load circuit breaker (WP 0004, Figure 1, Item 10) to OFF.

WARNING

Never attempt to connect or disconnect load cables while the generator set is running. Failure to observe this warning could result in severe personal injury or death by electrocution.

- Connect load cables to load terminals, refer to Installation of Load Cables.
- Perform all B (Before) PMCS procedures, refer to WP 0010, Table 1.
- Check that air intake cover (2) is in NORMAL operating (summer) position as indicated on top of filter cover (Figure 4).
- Ensure that fuel shutoff valve (WP 0004, Figure 1, Item 6) is in the ↓O (open) position.
- Connect 24 VDC battery source to NATO slave receptacle (11).

WARNING

If 24 VDC battery source is connected to the North Atlantic Treaty Organization (NATO) slave receptacle, DC voltages are present at generator set electrical components even with generator set shut down. Avoid grounding self when touching any electrical components. Failure to observe this warning can result in personal injury.

8. Move the engine RUN lever (4) to RUN position (Figure 5).

CAUTION

Do not crank engine more than 10 seconds without allowing the starter to cool for at least 15 seconds between attempted starts. Over cranking can damage the starter.

9. Turn START-PREHEAT/PREHEAT/OFF/START switch (WP 0004, Figure 1, Item 9) clockwise to START position. Release switch when engine starts.
10. If diesel engine fails to start, repeat Steps 8 and 9.
11. If engine still fails to start after two attempts, refer to WP 0007.
12. Disconnect 24 VDC battery source from NATO slave receptacle (11).
13. Check all gauges for proper indications as follows:

NOTE

If any gauge indicates an improper value, refer to the WP 0007.

- a. VOLTS AC meter (12) for 120 VAC (MEP-531A) or VOLTS DC meter (12) for 28 VDC (MEP-501A).
- b. HERTZ frequency meter (18) for 60-63 Hz (MEP-531A).
- c. % LOAD meter (13) under no load condition should read 0 (%). The reading will vary as the demand changes (from 0 to 125%).

NOTE

Under normal conditions, allow the diesel engine to warm-up for five minutes before applying a load. If necessary, the load can be applied immediately.

14. Switch ON-OFF load circuit breaker (WP 0004, Figure 1, Item 10) to ON to apply load.
15. Perform all D (During) PMCS procedures in accordance with WP 0010, Table 1.

END OF TASK**Electric Starting [23 °F (-5 °C) to -5 °F (-21 °C)]**

1. Ground generator set, refer to Installation of Ground Rods.
2. Switch ON-OFF load circuit breaker (WP 0004, Figure 1, Item 10) to OFF.

WARNING

Never attempt to connect or disconnect load cables while the generator set is running. Failure to observe this warning could result in severe personal injury or death by electrocution.

3. Connect load cables, refer to Installation of Load Cables.
4. Perform all PMCS (Before) procedures, refer to WP 0010, Table 1.
5. Ensure that fuel shutoff valve (6) is in the ↓O (open) position.
6. Connect 24 VDC battery source to NATO slave receptacle (11).

WARNING

If 24 VDC battery source is connected to the North Atlantic Treaty Organization (NATO) slave receptacle, DC voltages are present at generator set electrical components even with generator set shut down. Avoid grounding self when touching any electrical components. Failure to observe this warning can result in personal injury.

7. Move engine RUN lever (4) to RUN position (Figure 5).

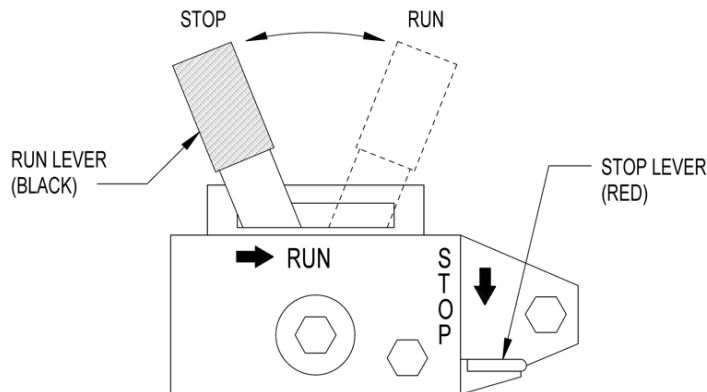

Figure 5. Engine RUN and STOP Controls.

8. Turn START-PREHEAT/PREHEAT/OFF/START switch (WP 0004, Figure 1, Item 9) counterclockwise to PREHEAT position for 1-1/2 minutes.

CAUTION

Do not crank engine more that 10 seconds without allowing the starter to cool for at least 15 seconds between attempted starts. Over cranking can damage the starter.

9. Turn START-PREHEAT/PREHEAT/OFF/START switch (9) clockwise to START position. Release switch when engine starts.
10. If diesel engine fails to start, repeat Steps 8 and 9.
11. If engine still fails to start after two attempts, refer to WP 0007.
12. Disconnect 24 VDC battery source from NATO slave receptacle (11).
13. Check all gauges for proper indications as follows:

NOTE

If any gauge indicates an improper value, refer to the WP 0007.

- a. VOLTS AC meter (12) for 120 VAC (MEP-531A) or VOLTS DC meter (12) for 28 VDC (MEP-501A).
- b. HERTZ frequency meter (18) for 60-63 Hz (MEP-531A).
- c. % LOAD meter (13) under no load condition should read 0 (%). The reading will vary as the demand changes (from 0 to 125%).

NOTE

Under normal conditions, allow the diesel engine to warm-up for five minutes before applying a load. If necessary, the load can be applied immediately.

14. Switch ON-OFF load circuit breaker (10) to ON to apply load.

15. Perform all (D) During PMCS procedures in accordance with WP 0010, Table 1.

END OF TASK

Electric Starting [Between -5 °F (-21 °C) to -25 °F (-32 °C)]

1. Ground generator set, refer to Installation of Ground Rods.
2. Switch ON-OFF load circuit breaker (WP 0004, Figure 1, Item 10) to OFF.

WARNING

Never attempt to connect or disconnect load cables while the generator set is running. Failure to observe this warning could result in severe personal injury or death by electrocution.

3. Connect load cables, refer to Installation of Load Cables.
4. Perform all B (Before) PMCS procedures, refer to WP 0010, Table 1.
5. Ensure that fuel shutoff valve (6) is in the ↓O (open) position.
6. Connect 24 VDC battery source to NATO slave receptacle (11).

WARNING

If 24 VDC battery source is connected to the North Atlantic Treaty Organization (NATO) slave receptacle, DC voltages are present at generator set electrical components even with generator set shut down. Avoid grounding self when touching any electrical components. Failure to observe this warning can result in personal injury.

7. Move the engine RUN lever (4) to the RUN position (Figure 5).
8. Turn air intake cover (WP 0004, Figure 1, Item 2) to COLD position, refer to Figure 6.
9. Turn START-PREHEAT/PREHEAT/OFF/START switch (WP 0004, Figure 1, Item 9) counterclockwise to PREHEAT position for 3 minutes.

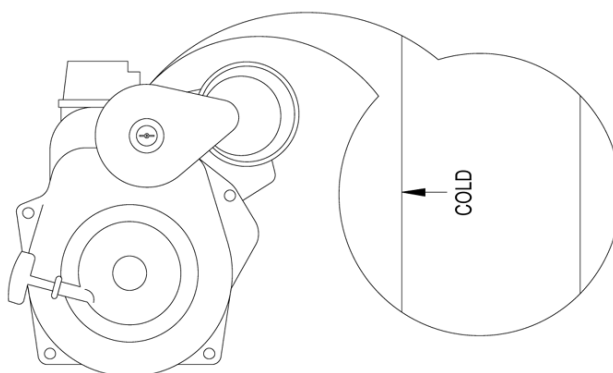

Figure 6. Air Intake Cover, Cold Operation.

CAUTION

Be sure to install the rubber plug (Figure 7) in the cylinder head cover opening after adding oil. Leaving the hole unplugged can lead to premature diesel engine failure as water, dirt, and debris entering the hole can damage internal parts. Do not add more than the specified amount of engine oil through the cylinder head cover.

10. Remove rubber plug "B" (Figure 7) in cylinder head cover and add 2 ml (to teaspoon) of clean engine oil, MIL-PRF-2104, 15W40. Install rubber plug.

CAUTION

Do not crank engine more that 10 seconds without allowing the starter to cool for at least 15 seconds between attempted starts. Over cranking can damage the starter.

11. Turn START-PREHEAT/PREHEAT/OFF/START switch (WP 0004, Figure 1, Item 9) counterclockwise to START-PREHEAT position. Release switch when engine starts.
12. If diesel engine fails to start, repeat Steps 9 and 11.
13. If engine still fails to start after two attempts, refer to operator troubleshooting index in WP 0007.
14. Disconnect 24 VDC battery source from NATO slave receptacle (11).
15. Check all gauges for proper indications as follows:

NOTE

If any gauge indicates an improper value, refer to the WP 0007.

- a. VOLTS AC meter (12) for 120 VAC (MEP-531A) or VOLTS DC meter (12) for 28 VDC MEP-501A).
- b. HERTZ frequency meter (18) for 60-63 Hz (MEP-531A).

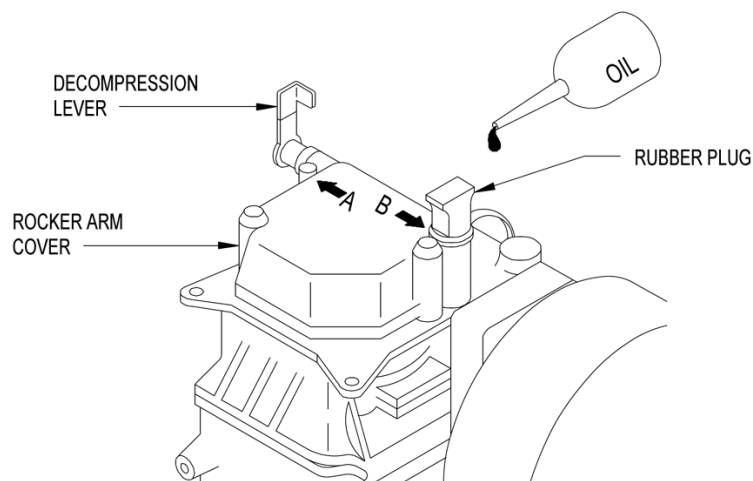

Figure 7. Adding Oil - Cylinder Head Cover Opening.

- c. % LOAD meter (13) under no load condition should read 0 (%). The reading will vary as the demand changes (from 0 to 125%).

NOTE

Under normal conditions, allow the diesel engine to warm-up for five minutes before applying a load. If necessary, the load can be applied immediately.

16. Switch ON-OFF load circuit breaker (10) to ON to apply load.
17. Perform all D (During) PMCS procedures in accordance with WP 0010, Table 1.

END OF TASK**Stopping Procedure**

1. Switch ON-OFF load circuit breaker (WP 0004, Figure 1, Item 10) to OFF position and allow engine to run approximately 3 minutes with no load.
2. Press engine STOP lever (5).

3. Perform all A (After) PMCS procedures in accordance with WP 0010, Table 1.

END OF TASK**IDENTIFICATION AND INSTRUCTION PLATES**

There are identification and instructions plates on the generator set. Figure 8 shows that location and contents of each plate on the generator set.

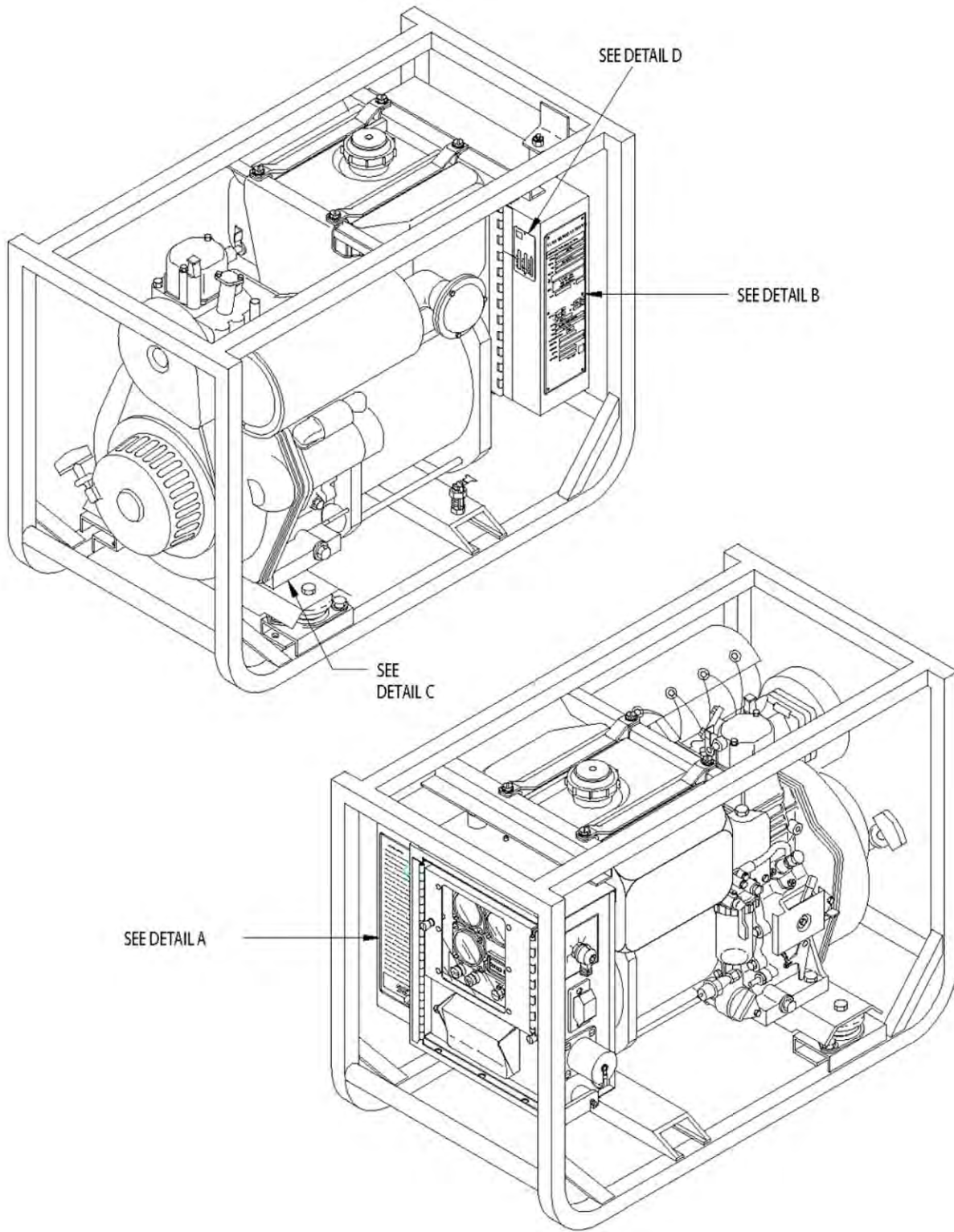
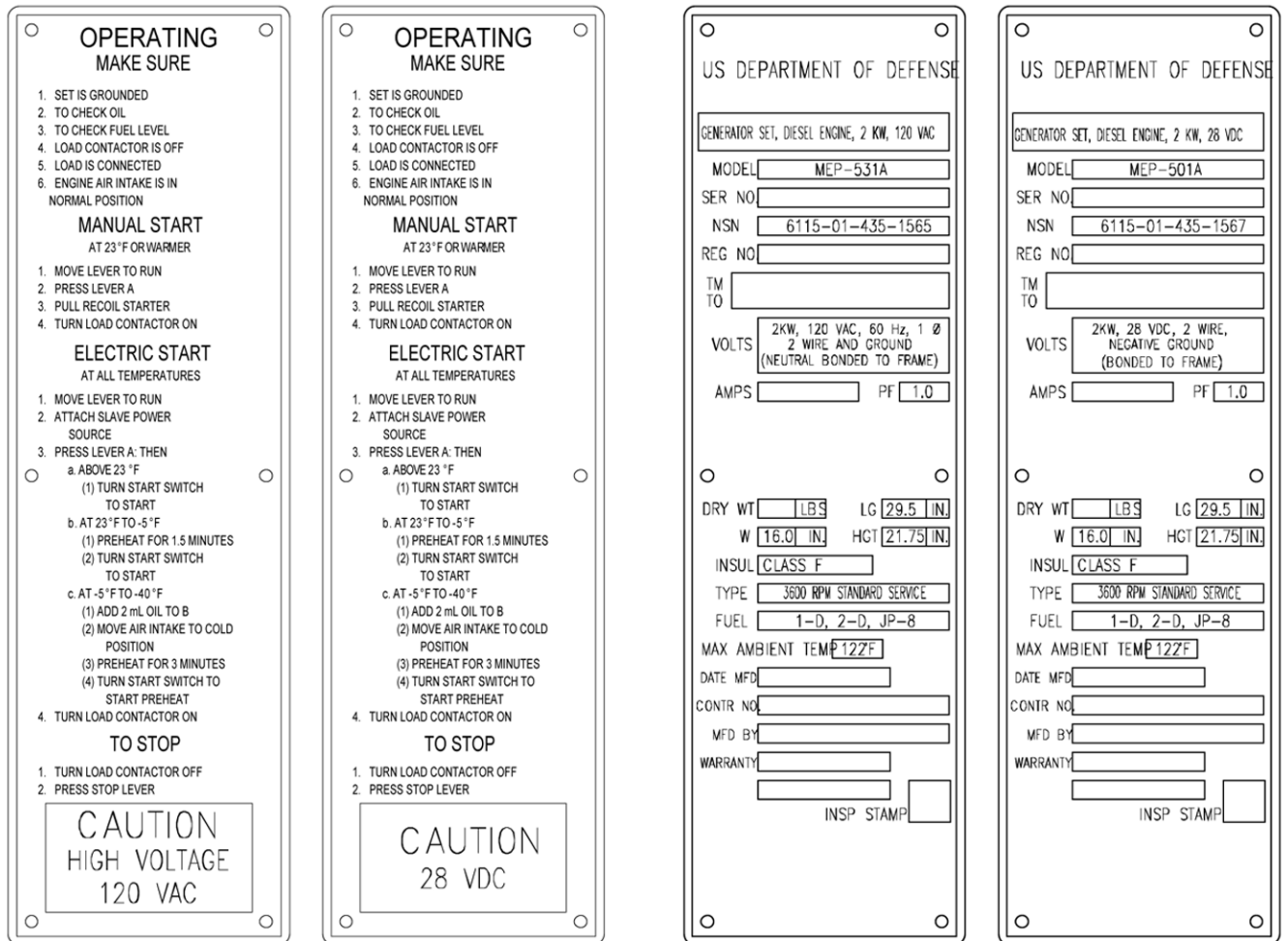

Figure 8. Decals and Instruction Plates (Sheet 1 of 2).



MEP-531A

MEP-501A

MEP-531A

MEP-501A

DETAIL A

DETAIL B

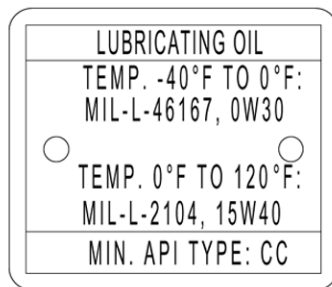

DETAIL C

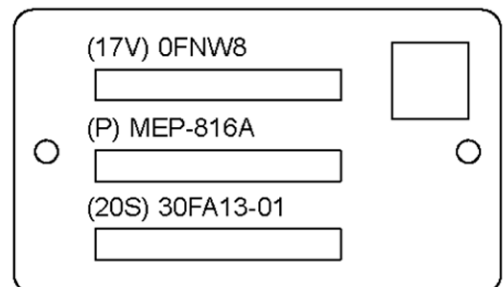

DETAIL D

Figure 8. Decals and Instruction Plates (Sheet 2 of 2).

PREPARATION FOR MOVEMENT

1. Shut down generator set. Refer to Stopping Procedures.
2. Disconnect load cables (Figure 2).
3. Disconnect ground cable (Figure 1) and remove ground rods.

4. Secure all generator set access doors and panels.
5. For initial set up after movement, refer to Stopping Procedure for assembly and preparation for use.

END OF TASK

END OF WORK PACKAGE

OPERATOR MAINTENANCE**2 kW MEP-501A/531A MILITARY TACTICAL GENERATOR SETS****OPERATION UNDER UNUSUAL CONDITIONS**

INITIAL SETUP:**Tools and Special Tools**

Tool Kit, General Mechanic's Automotive or
Standard Automotive Tool Set
(WP 0159, Table 2, Item 6)

Materials/Parts

Grounding Equipment
Cloth, Cleaning (WP 0162, Table 1, Item 4)
Lubricating, Oil (WP 0162, Table 1, Item 14)
Lubricating, Oil (WP 0162, Table 1, Item 15)
Decontaminating Solution Number 2 (DS2)
Super Tropical Bleach (STB)

Personnel Required

91D

References

WP 0004, Description and Use of Operator Controls
and Indicators
WP 0005, Operation Under Unusual Conditions
WP 0162, Expendable and Durable Items List
MIL-PRF-46167
MIL-PRF-2104
FM 3-11.3, NBC Warning and Reporting System
FM 3-11.4, NBC Protection
FM 3-11.5, NBC Decontamination

Equipment Condition

Generator set shut down (WP 0005, Stopping
Procedure)
Cable disconnected for NATO Slave Receptacle
(WP 0005)

UNUSUAL ENVIRONMENT / WEATHER**Operation in Extreme Cold [23 °F (-5 °C) to -51 °F (-46 °C)].**

The generator is designed for use in ambient temperatures as low as -51 °F (-46 °C). To ensure satisfactory operation, the following steps should be taken.

1. When possible, provide shelter from winds, freezing rain, and drifting snow. Position generator set behind a wind barrier.
2. When operated in an enclosed area, be sure that proper provisions are made for removal of exhaust gases.

CAUTION

Be careful not to scrape, scratch, gouge, or in any way damage the generator set. Avoid moving wiring as much as possible.

3. Remove accumulated snow or ice, if possible, by moving the generator set to a heated enclosure and allow the accumulation to melt after first wiping or brushing away loose deposits. When a heated enclosure is not available, remove snow or ice by wiping, brushing, or carefully picking the deposits away.
4. For extreme cold weather conditions, MIL-PRF-46167, 0W30 oil is recommended.

WARNING

Avoid contacting metal items with bare skin in extreme cold weather. Failure to observe this warning can result in personal injury.

5. Keep fuel tank at least full during cold weather operations.

END OF TASK

Operation in Extreme Heat [Above 120 °F (49 °C)].

1. When operating in extremely hot temperatures, attempt to place the generator set in a shaded area.
2. Provide as much ventilation as possible.
3. Keep all engine air passages and end cover openings clean and free of obstructions.
4. Make sure that air intake cover (WP 0004, Figure 1, Item 2) is turned so that ambient air is directed to air intake, see WP 0005, Figure 4.
5. Do not completely fill fuel tank. Leave one inch for fuel expansion.
6. Use MIL-PRF-2104 GR OE/HDO-30 (WP 0162, Table 1, Item 15) lubricating oil in diesel engine crankcase.

END OF TASK

Operation in Dusty or Sandy Areas

1. Shield generator set from dust and sand.
2. Clean dust and dirt from the generator set as required. Do not allow dust to accumulate around generator set.
3. Inspect and clean secondary (outer) air intake filter.
4. Keep generator air inlet and outlet slots clean.
5. Carefully remove dust and sand from control panel.
6. Keep area around fuel tank clean and free from dust and sand.

END OF TASK

Operation in Rainy or Humid Conditions

1. When not in use, cover generator set with canvas or other waterproof material. Remove cover during dry periods to allow unit to dry out.
2. Keep fuel tank full to prevent condensation.

END OF TASK

Operation in Salt Water Areas

CAUTION

Salt water is harmful to paint and is particularly corrosive when allowed to remain in contact with exposed metal surfaces.

1. Cover generator set with canvas or other material when it is not in use.
2. Wipe generator set down frequently with fresh water and allow it to dry thoroughly.

END OF TASK

Operation at High Altitudes

NOTE

The generator set is designed to produce 2 kW continuous at elevations up to 4,000 ft (1,219 m) above sea level, 95 °F (35 °C) ambient and 30 to 70% relative humidity without special service or adjustment.

END OF TASK

Operating Generator Set Output for High Altitudes and Temperatures.

1. To run the set at a higher altitude, derate output 1.3% for every 328 ft (100 m) above 4,000 ft (1,219 m). (Refer to Table 1.)
2. Provide adequate ventilation, as the engine is more likely to overheat at high altitudes.
3. When operating in high temperatures, derate 3% for every 50 °F (10 °C) above 95 °F (35 °C). (Refer to Table 1.)

Table 1. Altitude and Temperature Derating Calculation.

$\text{Altitude Deration} = \frac{[\text{Altitude} - 4,000 \text{ ft (1,219 m)}]}{328 \text{ ft (100 m)}} \times (0.013) \times (2,000 \text{ W})$ $\text{Temperature Deration} = \frac{[\text{Temperature} - 95 \text{ °F (35 °C)}]}{50 \text{ °F (10 °C)}} \times (0.03) \times (2,000 \text{ W})$ $\text{Total Deration} = 2,000 \text{ W} - \text{Altitude Deration} - \text{Temperature Deration}$

END OF TASK

INTERIM NUCLEAR, BIOLOGICAL, AND CHEMICAL (NBC) DECONTAMINATION PROCEDURES

The generator set is capable of being operated by personnel wearing nuclear, biological, or chemical (NBC) protective clothing without special tools or support equipment. Refer to FM 3-11.5, NBC Decontamination for information on decontamination procedures. Specific procedures for the generator set are the following:

1. Control panel indicators sealing gaskets, control panel door gaskets, access door gaskets, rubber tubing, coverings for electrical conduits, and retaining cord for slave receptacle cover will absorb and retain chemical agents. Replacement of these items is the recommended method of decontamination.
2. Lubricants and fuel may be present on the external surfaces of the generator set or components due to leaks or normal operation. These fluids will absorb NBC agents. The preferred method of decontamination is removal of these fluids using conventional decontamination methods in accordance with FM 3-11.5.
3. Continued decontamination of external generator set surfaces with super tropical bleach (STB) and decontaminating solution number 2 (DS2) will degrade clear plastic indicator coverings to a point where reading indicators will become impossible. This problem will become more evident for soldiers wearing protective masks. The use of STB and DS2 decontaminates in these areas should be minimized. Indicators should be decontaminated with warm, soapy water.
4. External surfaces of the control panel assembly that are marked with painted or stamped lettering will not withstand repeated decontamination with STB or DS2 without degradation of this lettering. The recommended method of decontamination for these areas is warm, soapy water.

5. Areas that will entrap contaminants, making efficient decontamination extremely difficult, include the following: space behind knobs and switches on the control panel, exposed heads of screws, areas adjacent to and behind exposed wiring conduits, hinged areas of access doors, spaces behind externally mounted equipment data plates, retaining cords for external receptacle covers, areas behind GFCI receptacle cover, access panel locking mechanisms, fuel cap, load output terminal board access door, NATO slave receptacle, frequency adjustment controls, areas around tie-down/lifting points, crevices around access doors, and external screens covering ventilation areas. Replacement of these items, if available, is the preferred method of decontamination. Conventional decontamination methods should be used on these areas, while stressing the importance of thoroughness and the probability of some degree of continuing contact and vapor hazard.
6. The use of overhead shelters or chemical protective covers is recommended as an additional means of protection against contamination in accordance with FM 3-11.5. If using covers, care should be taken to provide adequate space for airflow and exhaust.
7. For additional NBC information, refer to FM 3-11.3 and 3-11.4.

END OF TASK

END OF WORK PACKAGE

CHAPTER 3

OPERATOR TROUBLESHOOTING PROCEDURES

FOR

2 kW MILITARY TACTICAL GENERATOR SETS

MEP-531A

MEP-501A

CHAPTER 3
OPERATOR TROUBLESHOOTING PROCEDURES

WORK PACKAGE INDEX

<u>Title</u>	<u>WP Sequence No.</u>
Operator Troubleshooting Index.....	0007
Operator Troubleshooting Procedures	0008

OPERATOR MAINTENANCE

2 kW MEP-501A/531A MILITARY TACTICAL GENERATOR SETS

OPERATOR TROUBLESHOOTING INDEX

INITIAL SETUP:

Not Applicable

PURPOSE OF LOGIC TREE TABLE

WP 0008, Troubleshooting Figures 1 through 11 list common malfunctions that you may find with your equipment. Perform the tests, inspections, and corrective actions in the order they appear in the table. The troubleshooting tables cannot list all the malfunctions that may occur, all the tests and inspections needed to find the fault, or all the corrective actions needed to correct the fault. If the equipment malfunction is not listed or actions listed do not correct the fault, notify your supervisor.

NOTE

Before you use these procedures, be sure that all operator PMCS procedures have been performed, refer to WP 0010.

Malfunction/Symptom

Troubleshooting Procedure

Diesel Engine Will Not Start (Manual Starting)	Figure 1
Diesel Engine Will Not Start (Electric Starting)	Figure 2
Diesel Engine Runs Rough	Figure 3
Voltage Output Drops	Figure 4
Generator Set Vibrating/Bouncing Excessively	Figure 5
No Voltage Indication on VOLTS Meter (M2)	Figure 6
Voltage Indication on VOLTS Meter (M2) is High, Low, or Fluctuating	Figure 7
No Indication on % LOAD Meter (M1) With Load Applied	Figure 8
No Indication on HERTZ Frequency Meter (M4) (MEP-531A)	Figure 9
HOURS Meter (M3) Not Operating	Figure 10
Excessive Voltage Drop When Applying Load	Figure 11

END OF WORK PACKAGE

OPERATOR MAINTENANCE**2 kW MEP-501A/531A MILITARY TACTICAL GENERATOR SETS****OPERATOR TROUBLESHOOTING PROCEDURES**

INITIAL SETUP:**Tools and Special Tools**

Tool Kit, General Mechanic's Automotive or
Standard Automotive Tool Set
(WP 0159, Table 2, Item 6)

Personnel Required

91D

Equipment Condition

Generator set shut down (WP 0005, Stopping
Procedure)
Cable disconnected for NATO Slave Receptacle
(WP 0005)

Materials/Parts

Grounding Equipment

References

WP 0003, Theory of Operation
WP 0004, Description and Use of Operator Controls
and Indicators
WP 0005, Operation Under Usual Conditions
WP 0006, Operation Under Unusual Conditions
WP 0009, PMCS Introduction
WP 0010, Operator PMCS Instructions
WP 0011, Instrument Fuse (F1)
WP 0014, Siting
WP 0018, Air Filter Element
WP 0029, Fuel Tank Assembly
WP 0030, Air Intake System
WP 0035, Instrument Panel
WP 0036, Hertz Frequency Meter (MEP-531A)
WP 0037, Volts Meter (M2)
WP 0038, % Load Meter (M1)
WP 0039, Hours Meter
WP 0040, Voltage Adj. Potentiometer
WP 0053, On-Off Load Circuit Breaker Assembly
and Boot

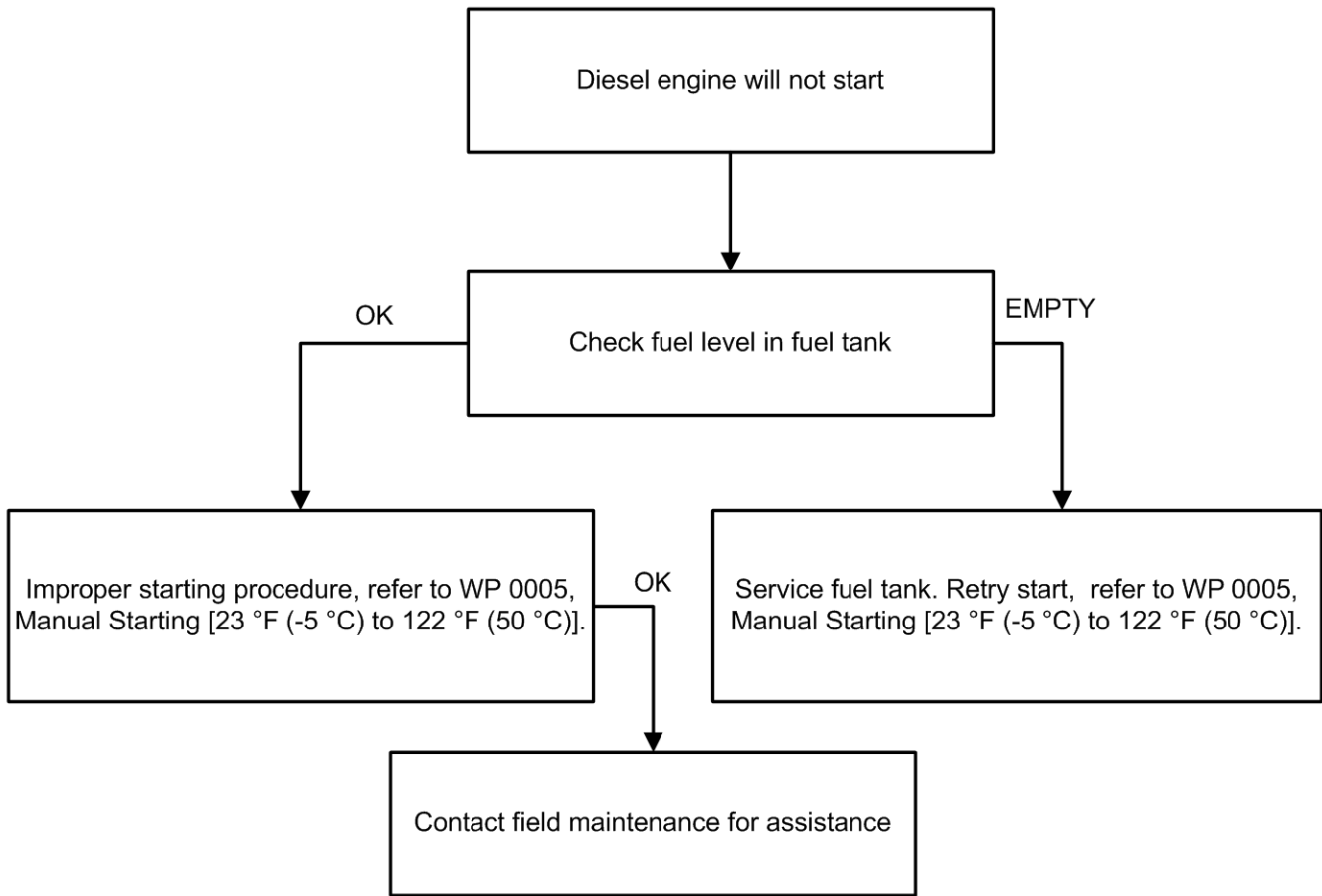

Figure 1. Diesel Engine Will Not Start (Manual Starting).

END OF TASK

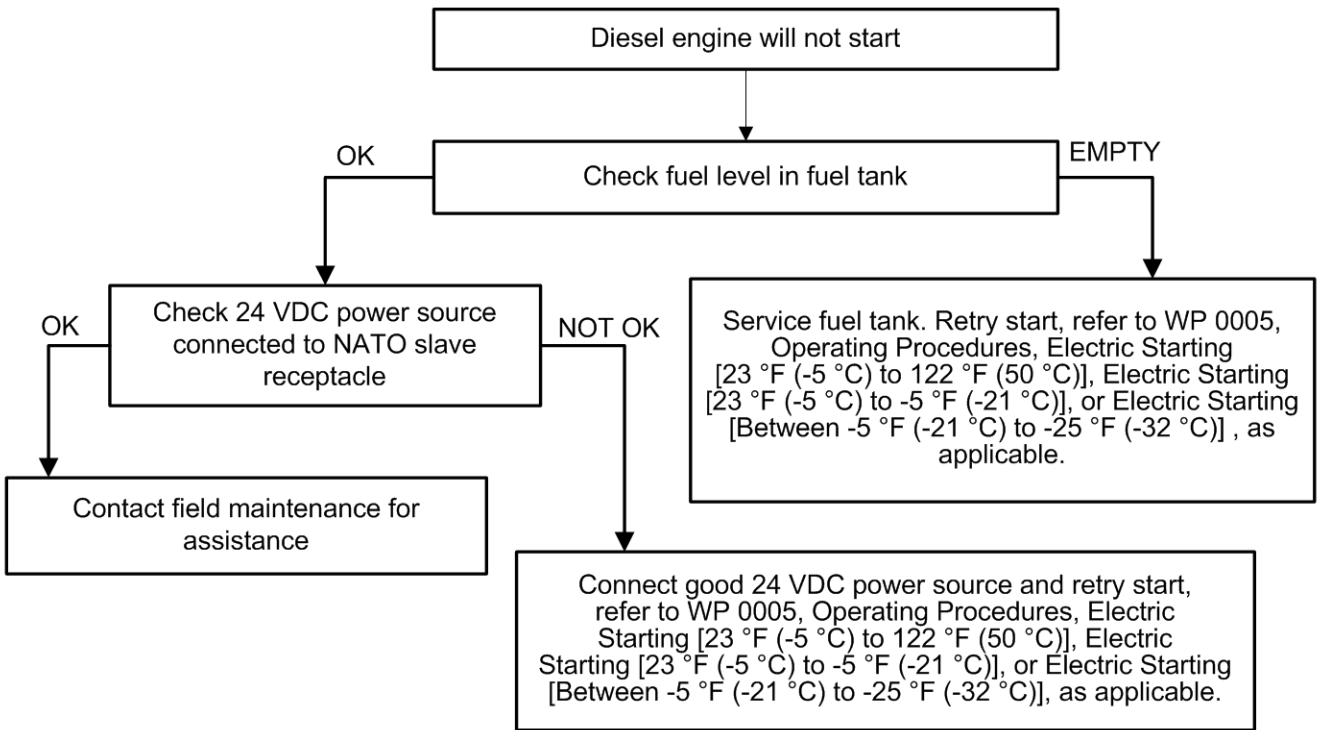

Figure 2. Diesel Engine Will Not Start (Electric Starting).

END OF TASK

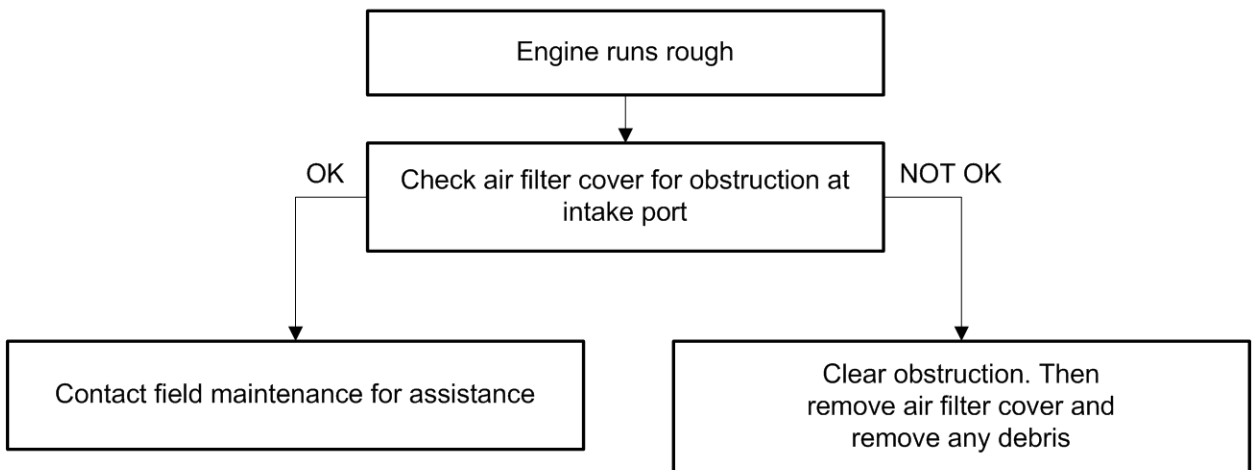

Figure 3. Diesel Engine Runs Rough.

END OF TASK

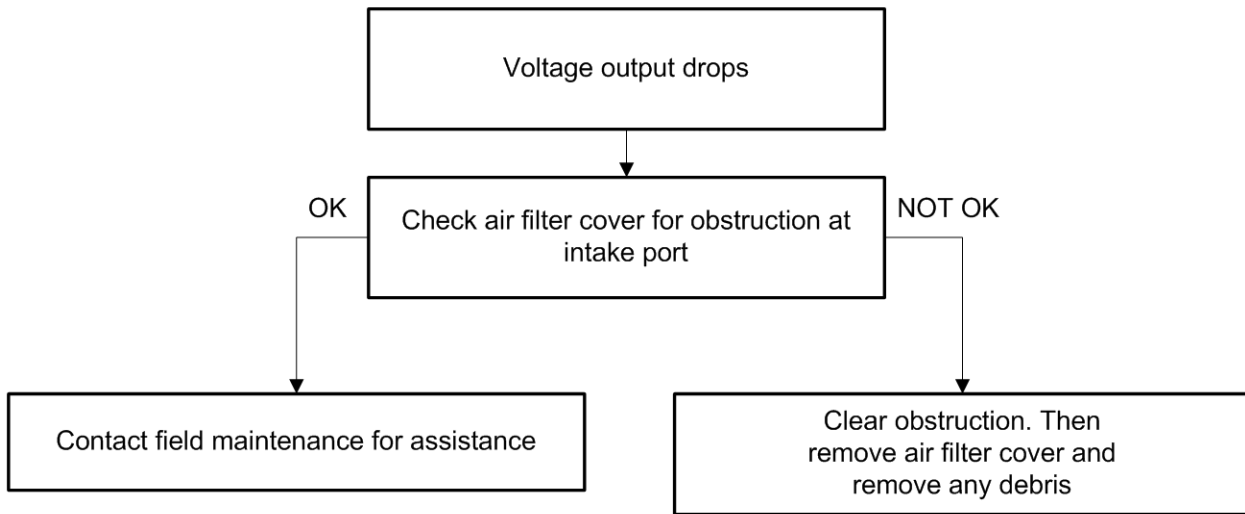

Figure 4. Voltage Output Drops.

END OF TASK

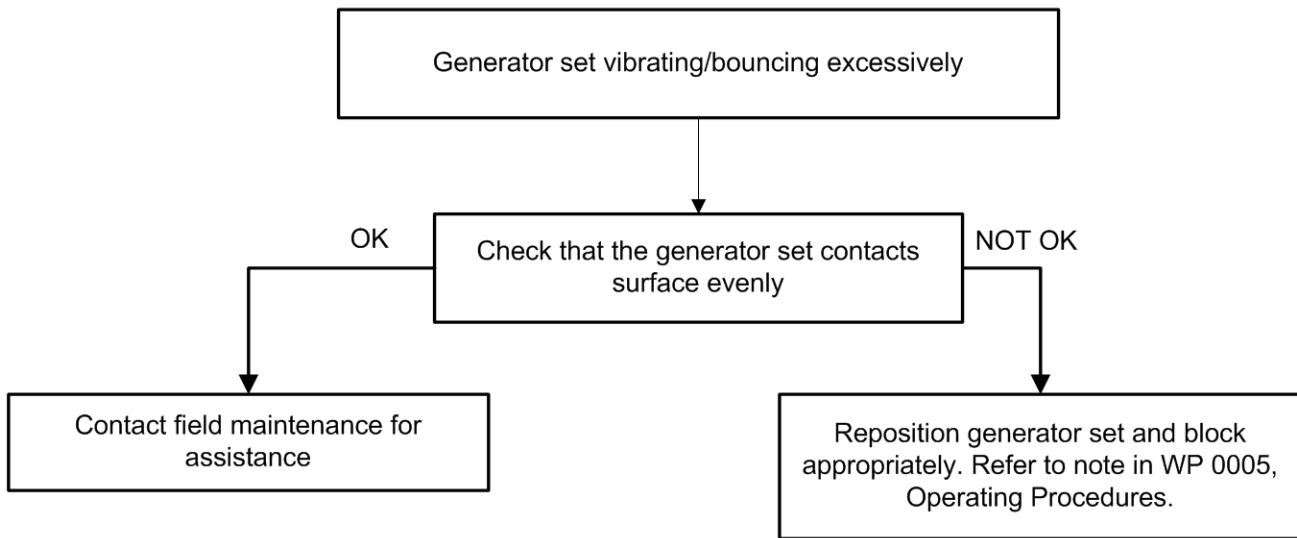

Figure 5. Generator Set Vibrating/Bouncing Excessively.

END OF TASK

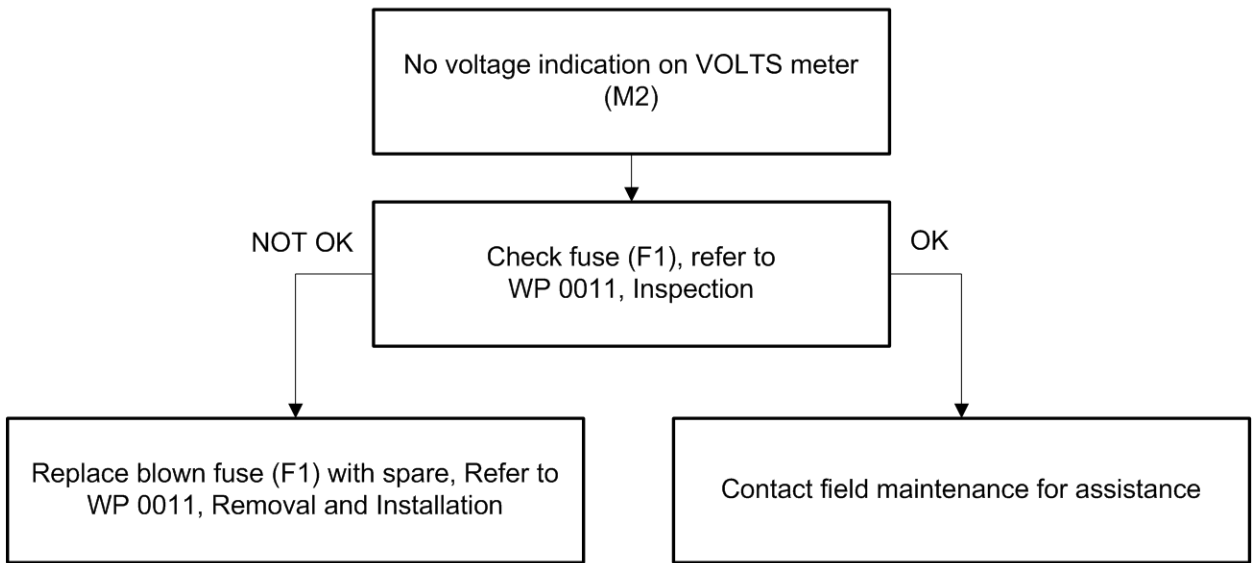

Figure 6. No Voltage Indication on VOLTS Meter (M2).

END OF TASK

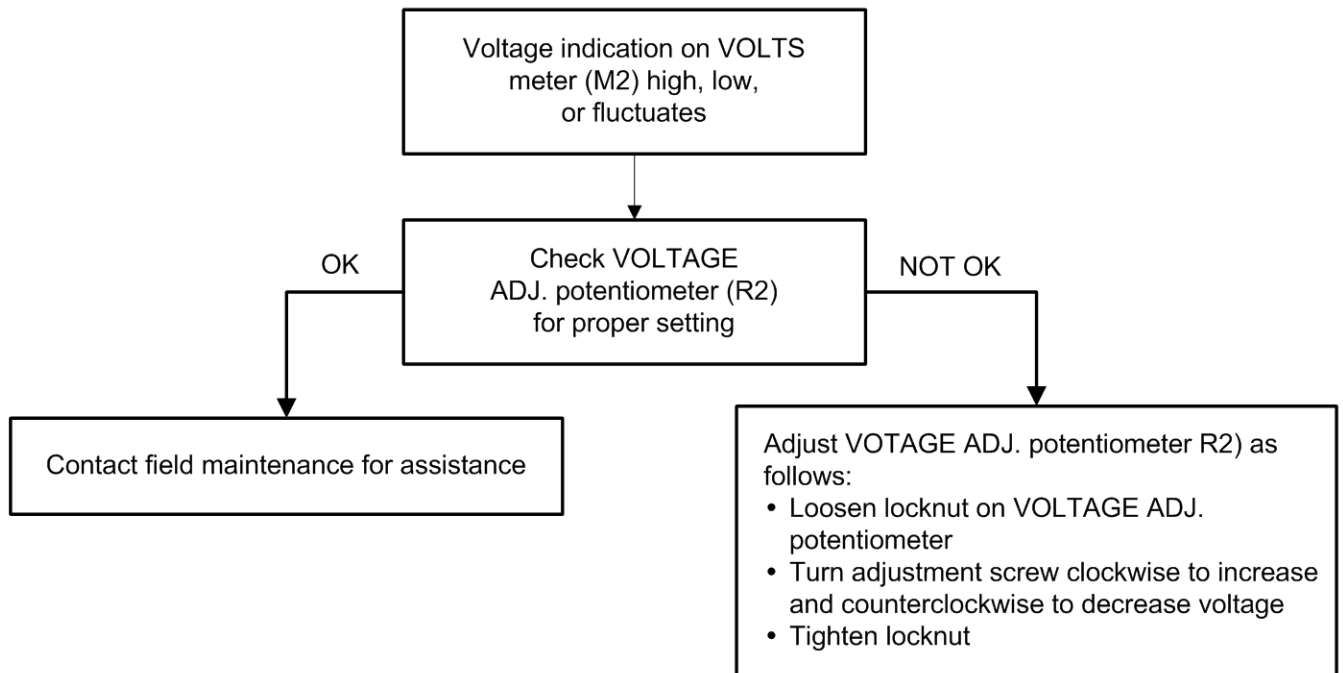

Figure 7. Voltage Indication on VOLTS Meter (M2) is High, Low, or Fluctuating.

END OF TASK

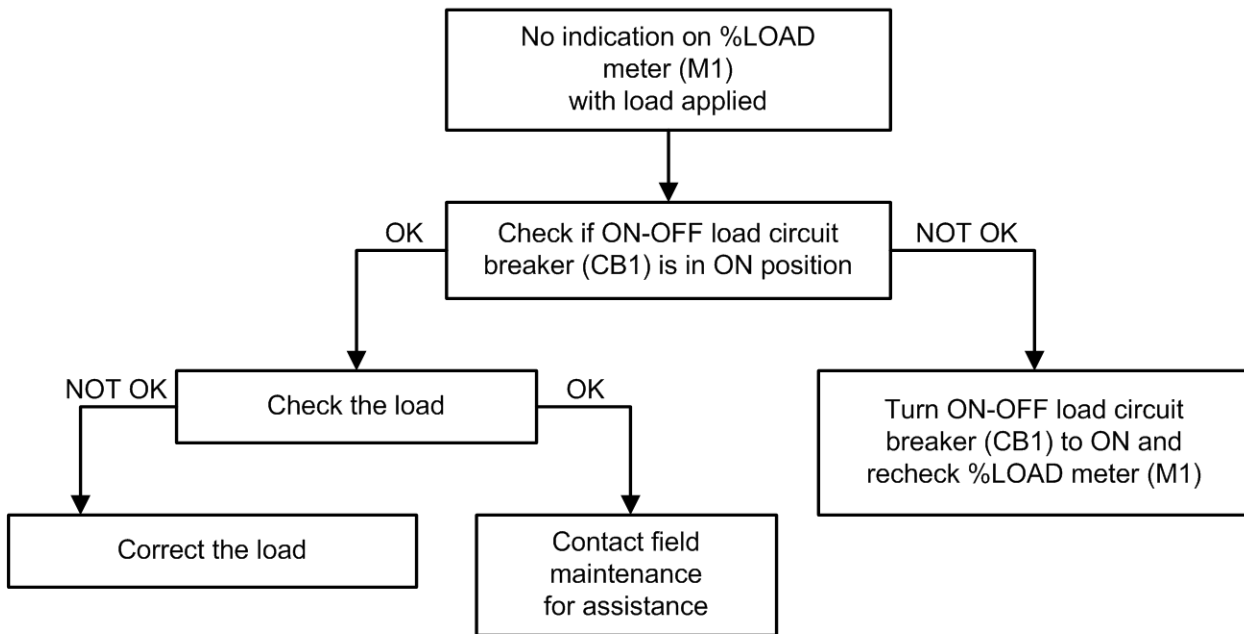

Figure 8. No Indication on % LOAD Meter (M1) With Load Applied.

END OF TASK

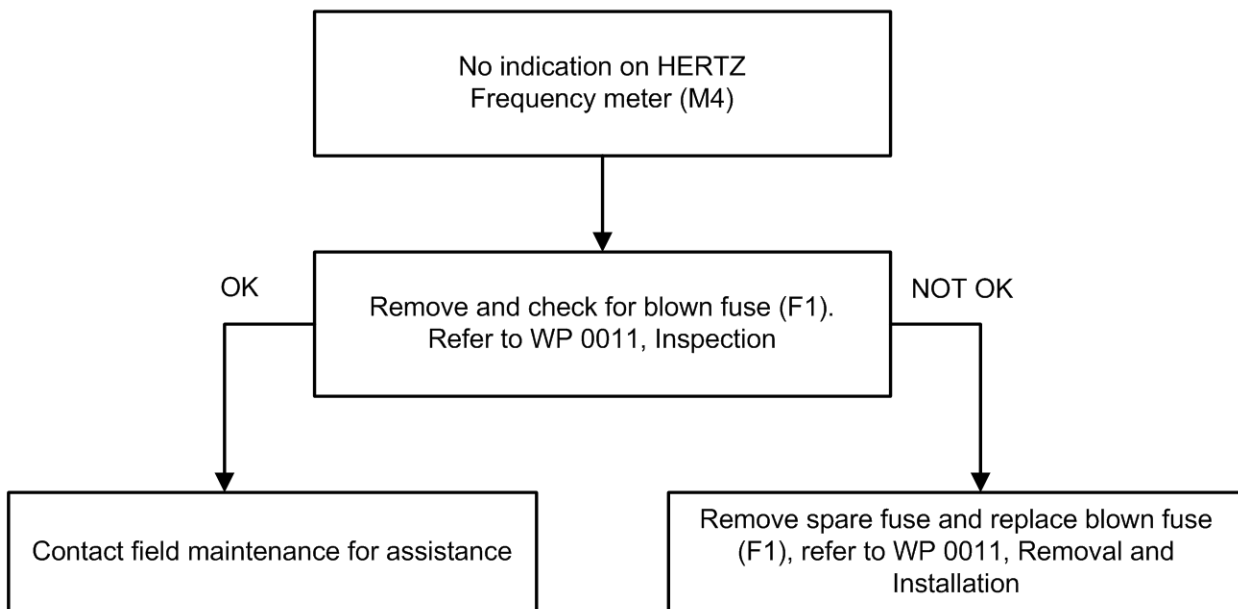

Figure 9. No Indication on HERTZ Frequency Meter (M4) (MEP-531A).

END OF TASK

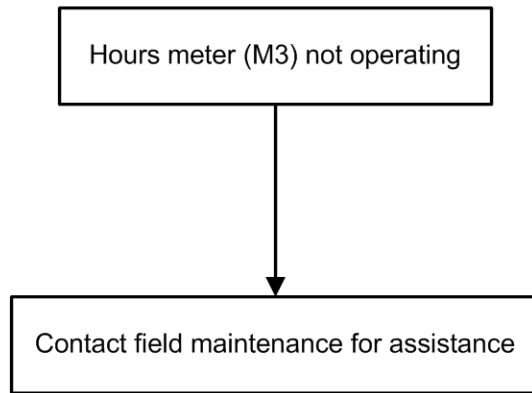

Figure 10. HOURS Meter (M3) Not Operating.

END OF TASK

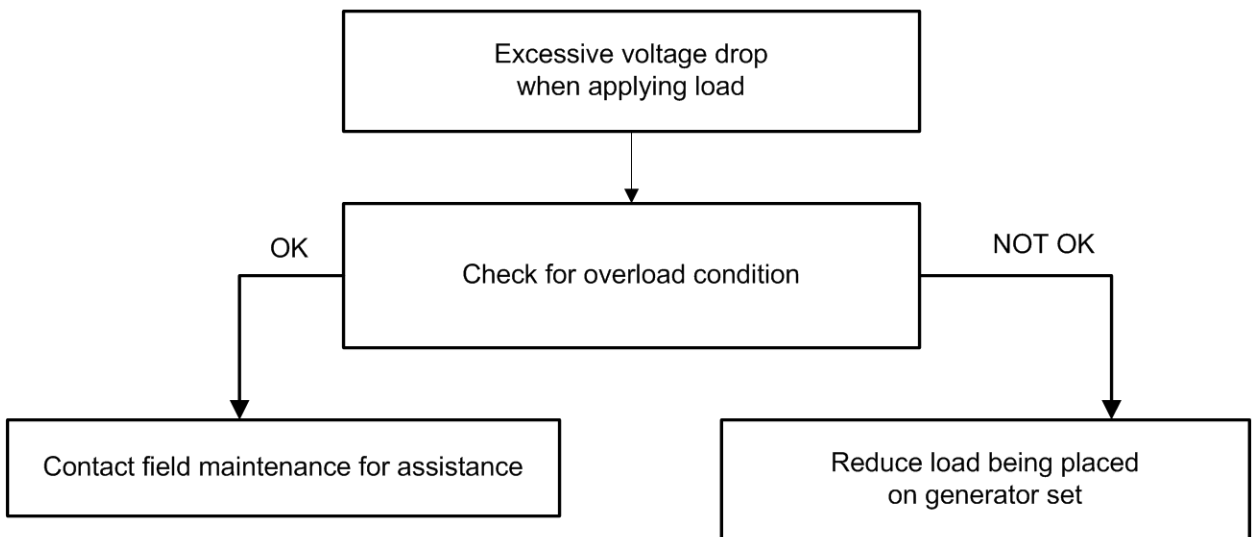

Figure 11. Excessive Voltage Drop When Applying Load.

END OF TASK

END OF WORK PACKAGE

CHAPTER 4

OPERATOR MAINTENANCE INSTRUCTIONS

FOR

2 kW MILITARY TACTICAL GENERATOR SETS

MEP-531A

MEP-501A

CHAPTER 4
OPERATOR MAINTENANCE INSTRUCTIONS

WORK PACKAGE INDEX

<u>Title</u>	<u>WP Sequence No.</u>
Operator PMCS Introduction	0009
Operator PMCS, Including Lubrication Instructions.....	0010
Instrument Fuse (F1)	0011

OPERATOR MAINTENANCE
2 kW MEP-501A/531A MILITARY TACTICAL GENERATOR SETS
OPERATOR PMCS INTRODUCTION

INITIAL SETUP:**Tools and Special Tools**

Tool Kit, General Mechanic's Automotive or Standard Automotive Tool Set (WP 0159, Table 2, Item 6)

Materials/Parts

Grounding Equipment

Personnel Required

91D

References

WP 0004, Description and Use of Operator Controls and Indicators
 WP 0007, Operator Troubleshooting Index
 WP 0010, Operator PMCS Instructions

Equipment Condition

Generator set shut down (WP 0005, Stopping Procedure)
 Cable disconnected for NATO Slave Receptacle (WP 0005)

INTRODUCTION TO OPERATOR PMCS TABLE

WP 0010, Table 1 (PMCS table) has been provided so you can keep your equipment in good operating condition and ready for its primary mission.

Preventive Maintenance Checks and Service (PMCS) are those scheduled procedures that are essential to the efficient operation of the equipment. PMCS prevent possible damage that might occur through neglect or failure to observe warning symptoms on time. Ensure all noted discrepancies are corrected.

WARNING

Remove metal jewelry when working on electrical system/components. Failure to observe this warning could cause severe personnel injury from electric shock.

Warnings and Cautions

Always observe the **WARNINGS**, **CAUTIONS**, and **NOTES** appearing in your PMCS table. Warnings and cautions appear before applicable procedures. You must observe these **WARNINGS** to prevent serious injury to yourself and others. You must observe **CAUTIONS** to prevent your equipment from being damaged. You must observe **NOTES** to ensure procedures are performed properly.

OPERATOR PMCS

WP 0010, Table 1 lists all scheduled maintenance tasks required for the generator set components and accessories. The columns of the PMCS table are described below.

Explanation of Table Entries

Item No. Column. Numbers in this column are for reference. When completing DA Form 2404 (Equipment Inspection and Maintenance Worksheet), include the item number for the check/service indicating a fault. Item numbers also appear in the order that you must do checks and services for the intervals listed.

Interval Column. This column tells you when you must do the procedure in the procedure column. Perform procedures such as "Monthly" or "Quarterly" at the listed calendar interval. Perform procedures designated by number of hours when the equipment has been operated for that many hours.

Item to be Checked or Serviced Column. This column lists the item to be checked or serviced.

Procedure Column. This column gives the procedures for checking or servicing the item listed in the item to be checked or serviced column. You must perform the procedure to know if the generator set is ready or available for its intended mission or operation. You must do the procedure at the time stated in the interval column.

Equipment Not Ready/Available if: Column. Information in this column tells you what faults will keep the generator set from being capable of performing its primary mission. If checks or services show faults listed in this column, do not return the generator set to service until the faults have been corrected.

NOTE

The terms ready/available and mission capable refer to the same status: generator set is on hand and is able to perform its combat missions (see DA Pam 750-8).

Other Table Entries

Be sure to observe all special information and notes that appear in your table.

Reporting and Correcting Deficiencies

If your generator set does not perform as required, refer to troubleshooting for possible problem. Any malfunctions, failures, or discrepancies shall be recorded on DA Form 2404 or DA Form 5988E and reported to higher-level maintenance, refer to DA PAM 750-8.

PREVENTIVE MAINTENANCE PROCEDURES

NOTE

Within designated intervals, these checks are to be performed in the order listed. If the generator set must be kept in continuous operation, check and service only those items that can be accessed without interrupting operations. Complete checks and services when the generator set is shut down.

PMCS, BEFORE Operations

Always keep in mind the CAUTIONS and WARNINGS. Perform your BEFORE PMCS.

PMCS, DURING Operations

Always keep in mind the CAUTIONS and WARNINGS. Perform your DURING PMCS.

After You Operate

Be sure to perform your AFTER PMCS.

Order in Which PMCS Will be Done

Always do preventive maintenance in the same order.

Routine Inspections

Use the following information to help identify potential problems before and during checks and services.

WARNING

Remove metal jewelry when working on electrical system/components. Failure to observe this warning could cause severe personnel injury from electric shock.

WARNING

High voltage is produced when this generator set is in operation. Use care when working around an open control panel with the generator set operating. Improper operation and/or failure to follow this warning could result in personal injury or death by electrocution.

WARNING

Cleaning solvents are flammable and toxic to eyes, skin, and respiratory tract. Skin/eye protection required. Avoid repeated/prolonged contact. Good general ventilation is normally adequate.

1. Keep it clean. Dirt, grease, and oil get in the way and may cover up a serious problem. Use dry cleaning solvent to clean metal surfaces.
2. Use soap and water to clean rubber or plastic parts and material.
3. Check all bolts, nuts, and screws to make sure they are not loose, missing, bent, or broken. DO not try to check them all with a tool, but look for chipped paint, bare metal, or rust around bolt heads. If you find one loose, tighten it or report it to field level maintenance.
4. Inspect welds. Look for loose or chipped paint, rust, or gaps where parts are welded together. If a broken weld is found, report it to field level maintenance.
5. Inspect electrical wires, connectors, terminals, and receptacles. Look for cracked or broken insulation, bare wires, and loose or broken connectors. Tighten loose connectors and make sure wires are in good condition. Examine terminals and receptacles for serviceability. If deficiencies are found, report them to field level maintenance.
6. Inspect hoses and fluid lines. Look for wear, damage, and leaks. Make sure that clamps and fittings are tight. Wet spots and stains around a fitting or connector can mean a leak. If a leak comes from a loose connector, or if something is broken or worn out, report it to field level maintenance.

CORROSION PREVENTION AND CONTROL (CPC)

Corrosion Prevention and Control (CPC) of Army materiel is a continuing concern. It is important that any corrosion problems with this item be reported so that the problem can be corrected and improvements can be made to prevent the problem in future items. Corrosion specifically occurs with metals. It is an electrochemical process that causes the degradation of metals. It is commonly caused by exposure to moisture, acids, bases, or salts. An example is the rusting of iron. Corrosion damage in metals can be seen, depending on the metal, as tarnishing, pitting, fogging, surface residue, and/or cracking. Plastics, composites, and rubbers can also degrade. Degradation is caused by thermal (heat), oxidation (oxygen), solvation (solvents), or photolytic (light, typically UV) processes. The most common exposures are excessive heat or light. Damage from these processes will appear as cracking, softening, swelling, and/or breaking. SF Form 368, Product Quality Deficiency Report should be submitted to the address specified in DA PAM 750-8, The Army Maintenance Management System (TAMMS) Users Manual.

FLUID LEAKAGE

It is necessary for you to know how fluid leakage affects the status of the 2 kW Generator Set. Following are types/classes of leakage you need to know to be able to determine the status of the 2 kW Generator Set. Learn these leakage definitions and remember - when in doubt, notify your supervisor. Equipment operation is allowed with minor leakage (Class I or II). Consideration must be given to fluid capacity in the item/system being checked/inspected. When in doubt, notify your supervisor.

When operating with Class I or II leaks, continue to check fluid levels as required in the PMCS.

Class III leaks should be reported immediately to your supervisor.

Table 1. Leakage Definitions.

Leakage Class	Leakage Definition
Class I	Seepage of fluid (as indicated by wetness or discoloration) not great enough to form drops.
Class II	Leakage of fluid great enough to form drops, but not enough to cause drops to drip from the item being checked/inspected.
Class III	Leakage of fluid (other than fuel) greater than three drops per minute that fall from the item being checked/inspected.

CAUTION

Equipment operation is allowable with minor leakages (Class I or II). Of course, consider the fluid capacity of the item/system being checked/inspected. When in doubt, notify maintenance.

While operating with Class I or Class II leaks, continue to check fluid levels as required in your PMCS. All leaks should be reported to maintenance.

END OF WORK PACKAGE

OPERATOR MAINTENANCE

**2 kW MEP-501A/531A MILITARY TACTICAL GENERATOR SETS
OPERATOR PMCS, INCLUDING LUBRICATION INSTRUCTIONS**

INITIAL SETUP:

Tools and Special Tools

Tool Kit, General Mechanic's Automotive or Standard Automotive Tool Set (WP 0159, Table 2, Item 6)
Multimeter (WP 0159, Table 2, Item 3)

Materials/Parts

Grounding Equipment
Cloth, Cleaning (WP 0162, Table 1, Item 4)
Lubricating, Oil (WP 0162, Table 1, Item 14)
Lubricating, Oil (WP 0162, Table 1, Item 15)

References

WP 0004, Description and Use of Operator Controls and Indicators
WP 0007, Operator Troubleshooting Index
MIL-PRF-46167 0W30
MIL-PRF-2104-15W40

Equipment Condition

Generator set shut down (WP 0005, Stopping Procedure)
Cable disconnected for NATO Slave Receptacle (WP 0005)

OPERATOR LUBRICATION INSTRUCTIONS

Lubrication not required by the operator.

CAUTION

Equipment operation is allowable with minor leakages (Class I or II). Of course, consider the fluid capacity of the item/system being checked/inspected. When in doubt, notify maintenance.

NOTE

Within designated intervals, these checks are to be performed in the order listed.

Table 1. Operator Preventive Maintenance Checks and Services for MEP-501A/MEP-531A.

ITEM NO.	INTERVAL	ITEM TO BE CHECKED OR SERVICED	PROCEDURE	EQUIPMENT NOT READY/AVAILABLE IF:
GENERATOR SET				
1	BEFORE	Control Panel	Check ON-OFF load circuit breaker for damage. <div style="text-align: center;">  </div>	ON-OFF load circuit breaker damaged.

Table 1. Operator Preventive Maintenance Checks and Services for MEP-501A/MEP-531A. - Continued

ITEM NO.	INTERVAL	ITEM TO BE CHECKED OR SERVICED	PROCEDURE	EQUIPMENT NOT READY/AVAILABLE IF:
	BEFORE and AFTER	Instrument Panel	Check window protecting instrument panel for damage.	
	BEFORE and AFTER	Instrument Panel	Check all indicators and controls for damage and missing parts.	Indicators or controls damaged or missing.
	DURING	Instrument Panel	Check all indicators for proper operation.	VOLTS Meter or HERTZ frequency meter (MEP-531A) inoperative.
2	BEFORE and AFTER	Identification and Instruction Plates	Check all identification and instruction plates for damage, security, and legibility. Refer to WP 0005, Figure 8.	Safety or operation instruction decal missing or illegible.
3	BEFORE	Load Terminals	Inspect load terminals for damage and security. <div data-bbox="802 852 889 1121" style="text-align: center;">  </div>	Load terminals damaged or loose. Retaining clips missing or damaged.
4	BEFORE and DURING	Ground terminal stud	Inspect ground terminal stud for damage. Ensure generator set is properly grounded. <div data-bbox="711 1356 997 1545" style="text-align: center;">  </div>	Generator set ground terminal stud is damaged or generator set not properly grounded. Retaining clip missing or damaged.

Table 1. Operator Preventive Maintenance Checks and Services for MEP-501A/MEP-531A. - Continued

ITEM NO.	INTERVAL	ITEM TO BE CHECKED OR SERVICED	PROCEDURE	EQUIPMENT NOT READY/AVAILABLE IF:
5	BEFORE	Air Intake Cover Wing Nut	<p>Check air intake cover wing nut for security. Tighten if necessary.</p> 	Air intake cover cannot be secured.
6	BEFORE and AFTER	Filter Assembly, Fuel	<p>Inspect fuel filter assembly for damage and security. Check fuel filter bowl for water or other contaminants.</p> 	Fuel bowl contains water or contaminants.
7	BEFORE, DURING and AFTER	Fuel System	<p>Inspect fuel system for loose or missing fuel line clamps, damaged fuel lines, and leaking/damaged fuel tank. Check for evidence of fuels leaks.</p> <p>Check fuel level and if necessary, service fuel tank to red line on fuel strainer. Ensure fuel tank fill neck strainer is not clogged or damaged.</p> <p>The following fuels may be used between -51 and 122 °F (-46 and 50 °C):</p> <ol style="list-style-type: none"> DL-1 (A-A-52557) [-26 to 0 °F (-32 to -18 °C)] DL-2 (A-A-52557) [0 to 122 °F (-18 to 50 °C)] JP-8 (MIL-DTL-83133) [-26 to -51 °F (-32 to -46 °C)] 	Any fuel leaks, or damaged, loose, or missing parts.

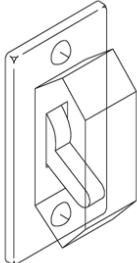
Table 1. Operator Preventive Maintenance Checks and Services for MEP-501A/MEP-531A. - Continued

ITEM NO.	INTERVAL	ITEM TO BE CHECKED OR SERVICED	PROCEDURE	EQUIPMENT NOT READY/AVAILABLE IF:
DIESEL ENGINE				
8	BEFORE and AFTER	Crankcase Oil	<p>Ensure generator set is level and check diesel engine lubricating oil level using oil fill cap/dipstick (do not screw in oil fill cap/dipstick when checking oil level). Refer to WP 0004, Figure 1, Item 8 for the locations of oil fill cap/dipstick. Add oil if required for the following operating environments: MIL-PRF-46167, 0W30 [-40 to 0 °F (-40 to -18 °C)] MIL-PRF-2104, 15W30 [0 to 120 °F (-18 to 49 °C)]</p> 	
	BEFORE, DURING and AFTER	Crankcase Oil	Inspect the diesel engine and surrounding area for oil leaks.	Class III oil leaks.
9	BEFORE, DURING and AFTER	Cylinder head cooling fins and recoil starter cover	<p>Inspect cooling fins and air intake slots in recoil starter cover for damage and debris restricting air flow over and through cooling fins. Remove debris. Check recoil starter assembly for damage and operation.</p> 	Any damaged, loose, or missing parts.
10	BEFORE	Spark Arrester	Check daily for carbon buildup.	Spark arrester is blocked or buildup is present.

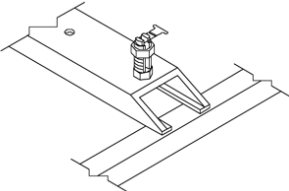
MANDATORY REPLACEMENT PARTS LIST

There are no replacement parts required for these PMCS procedures.

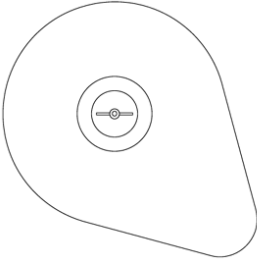
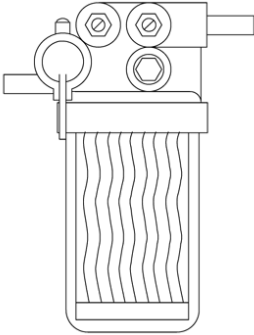
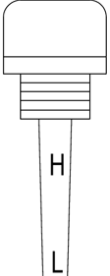
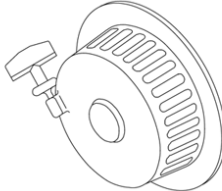
END OF WORK PACKAGE

OPERATOR MAINTENANCE**2 kW MEP-501A/531A MILITARY TACTICAL GENERATOR SETS
INSTRUMENT FUSE (F1): REMOVAL, INSPECTION, INSTALLATION**

INITIAL SETUP:**Tools and Special Tools**

Tool Kit, General Mechanic's Automotive or
Standard Automotive Tool Set
(WP 0159, Table 2, Item 6)

Materials/Parts

As required

References

WP 0034, Instrument Cover

Equipment Condition

Generator set shut down (WP 0005, Stopping
Procedure)
Cable disconnected for NATO Slave Receptacle
(WP 0005)

WARNING

High voltage is produced when this generator set is in operation. Use care when working around an open control panel with the generator set operating. Improper operation and/or failure to follow this warning could result in personal injury or death by electrocution.

WARNING

Remove metal jewelry when working on electrical system/components. Failure to observe this warning could cause severe personnel injury from electric shock.

REMOVAL

1. Shut down generator set.
2. Release instrument cover by turning fastener. Open instrument cover.
3. Remove cap and fuse (Figure 1).

END OF TASK**NOTE**

If there is no fuse in the spare fuse holder, contact field maintenance for the proper replacement.

INSPECTION

1. Inspect fuse (Figure 1) for cracks and burned out element. Discard fuse if defective. If necessary, remove spare fuse from spare fuse holder.
2. Inspect contacts in cap and fuse holder for evidence of corrosion and damage. If corroded or damaged, contact Field maintenance for repair.

END OF TASK**INSTALLATION**

1. Insert fuse into fuse holder and install cap (Figure 1).
2. Close and secure instrument cover.

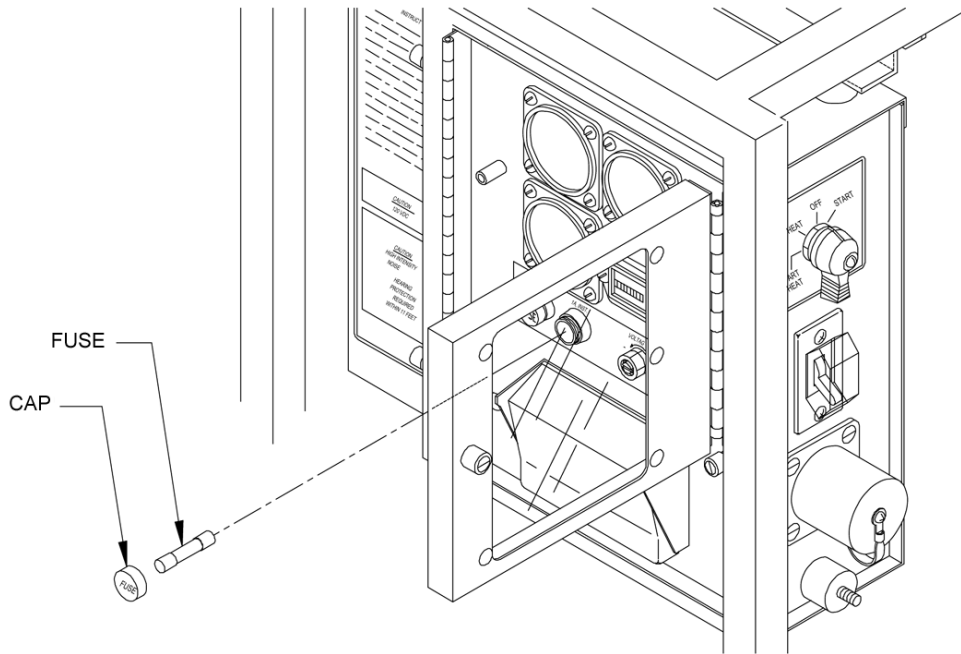

Figure 1. Fuse (F1) Replacement.

END OF TASK

END OF WORK PACKAGE

CHAPTER 5

FIELD TROUBLESHOOTING PROCEDURES

FOR

2 kW MILITARY TACTICAL GENERATOR SETS

MEP-531A

MEP-501A

CHAPTER 5
FIELD TROUBLESHOOTING PROCEDURES

WORK PACKAGE INDEX

<u>Title</u>	<u>WP Sequence No.</u>
Field Troubleshooting Index	0012
Field Troubleshooting Procedures.....	0013

FIELD MAINTENANCE
2 kW MEP-501A/531A MILITARY TACTICAL GENERATOR SETS
FIELD TROUBLESHOOTING INDEX

INITIAL SETUP:

Not Applicable

FIELD TROUBLESHOOTING**WARNING**

Exhaust discharge contains deadly gases. Do not operate generator set in enclosed area unless exhaust discharge is properly vented outside. Position as far away from personnel, shelters, and occupied vehicles as possible. Failure to observe this warning could result in severe personal injury or death due to carbon monoxide poisoning.

WARNING

The fuels in this generator set are flammable. Do not smoke or use open flames when performing maintenance. Do not service or drain the fuel system while open flames are present. Flames and explosion could result in severe personal injury or death. Use a container or cloth to catch any excess fuel to prevent spilling over engine components. Be sure to properly dispose of diesel fuel and diesel fuel soaked cloths.

WARNING

High voltage is produced when this generator set is in operation. Use care when working around an open control panel with the generator set operating. Improper operation and/or failure to follow this warning could result in personal injury or death by electrocution.

WARNING

MEP-531A engine/alternator assembly weighs 100 lbs (45.4 kg). MEP-501A engine/alternator assembly weighs 80 lbs (36.2 kg). Use caution when removing assembly to prevent personal injury.

NOTE

Before you use these procedures, be sure that all operator and field level PMCS procedures have been performed.

NOTE

Ensure operator level troubleshooting has been performed prior to performing field level troubleshooting.

NOTE

Refer to the Electrical Schematic Figure FO-1 (MEP-531A), Figure FO-2 (MEP-501A), Figure FO-5 (Mechron 120 VAC), or Figure FO-6 (Mechron 28 VDC) and Wiring Diagram Figure FO-3 (MEP-531A) or Figure FO-4 (MEP-501A) as troubleshooting aids.

Malfunction/Symptom**Troubleshooting
Procedure**

Diesel Engine Will Not Start (Manual Starting)	Figure 1
Diesel Engine Will Not Start (Electric Starting)	Figure 2
Diesel Engine Hard To Start	Figure 3
Diesel Engine Starts but Fails to Keep Running	Figure 4
Diesel Engine Runs Erratic	Figure 5
Diesel Engine Runs Rough	Figure 6
Unexpected Reverse Rotation at Startup	Figure 7
Diesel Engine Races Exceeding Governed Speed	Figure 8
Diesel Engine Runs Unevenly (Surges)	Figure 9
Diesel Engine Seizes During Operation	Figure 10
Diesel Engine Stops During Operation	Figure 11
Diesel Engine Exhausts Black Smoke	Figure 12
Diesel Engine Exhausts Blue-White Smoke	Figure 13
Recoil Start Rope Hard to Pull	Figure 14
Voltage Output Drops (MEP-531A)	Figure 15
Voltage Output Drops (MEP-501A)	Figure 16
No Output Voltage (MEP-531A)	Figure 17
No Output Voltage (MEP-501A)	Figure 18
Generator Set Vibrating/Bouncing Excessively	Figure 19
No Voltage Indication on VOLTS Meter (M2)	Figure 20
No Indication on % LOAD Meter (M1) (MEP-531A)	Figure 21
No Indication on % LOAD Meter (M1) (MEP-501A)	Figure 22
No Indication on HERTZ Frequency Meter (M4) (MEP-531A)	Figure 23
No Indication on HOURS Meter (M3)	Figure 24
No Output from Alternator (MEP-531A)	Figure 25
No Output from Alternator (MEP-501A)	Figure 26
Air Intake Preheaters Do Not Operate	Figure 27
Cannot Adjust Alternator Output With VOLTAGE ADJ. Potentiometer	Figure 28

END OF WORK PACKAGE

FIELD MAINTENANCE**2 kW MEP-501A/531A MILITARY TACTICAL GENERATOR SETS****FIELD TROUBLESHOOTING PROCEDURES**

INITIAL SETUP:**Tools and Special Tools**

Tool Kit, General Mechanic's Automotive or
Standard Automotive Tool Set
(WP 0159, Table 2, Item 6)

Personnel Required

91D

Equipment Condition

Generator set shut down (WP 0005, Stopping
Procedure)
Cable disconnected for NATO Slave Receptacle
(WP 0005)

Materials/Parts

As required

References

WP 0012, Field Troubleshooting Index
WP 0017, Fuel Filter Element
WP 0019, Fuel Injector
WP 0020, Alternator Brushes Inspection
(MEP-531A)
WP 0022, Engine Resilient Mounts
WP 0023, Alternator Resilient Mount (MEP-531A)
WP 0024, Alternator Resilient Mount (MEP-501A)
WP 0025, Cylinder Head Nuts
WP 0031, Spark Arrestor
WP 0041, Instrument Shunt (MEP-501A)
WP 0047, Start-Preheat/Preheat/Off/Start Rotary
Switch
WP 0049, NATO Slave Receptacle
WP 0059, Electromagnetic Interference (EMI) Filter
(MEP-531A)
WP 0060, Low Oil Pressure (LOP) Switch
WP 0062, LOP Engine Shut Down Cable
WP 0063, Air Intake Heating Elements and Pipe
WP 0064, Governor Regulator Bracket
WP 0066, Recoil Starter Assembly
WP 0067, Engine Oil Strainer
WP 0074, Generator Control Unit
WP 0075, Voltage Regulator
WP 0082, Cylinder Head
WP 0083, Intake and Exhaust Valves
WP 0084, Fuel Injection Pump
WP 0088, Dynamo
WP 0089, AC Alternator (MEP-531A)
WP 0090, AC Alternator Bearing (MEP-531A)
WP 0092, DC Alternator Bearings (MEP-501A)
WP 0094, Frame

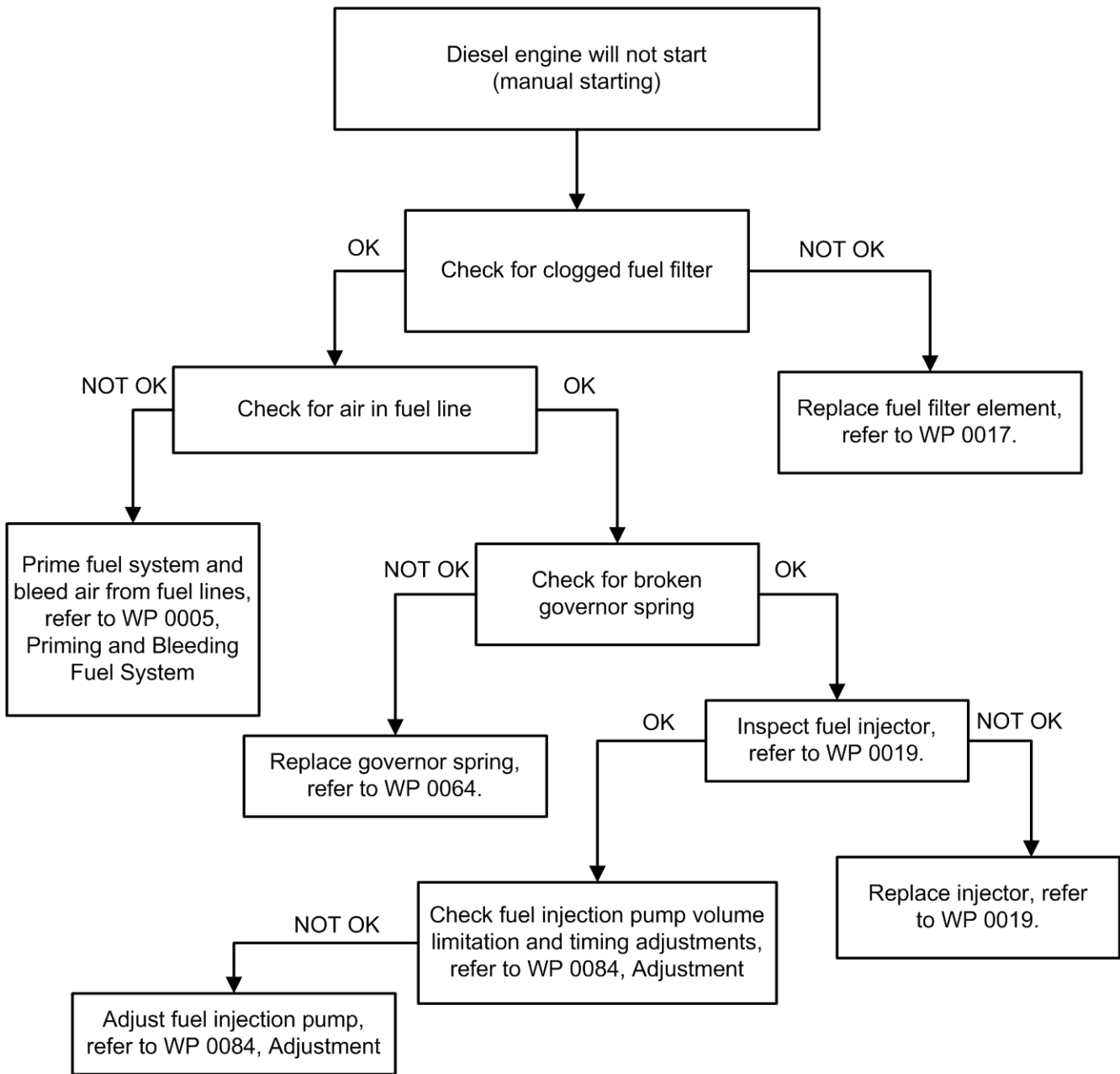

Figure 1. Diesel Engine Will Not Start (Manual Starting).

END OF TASK

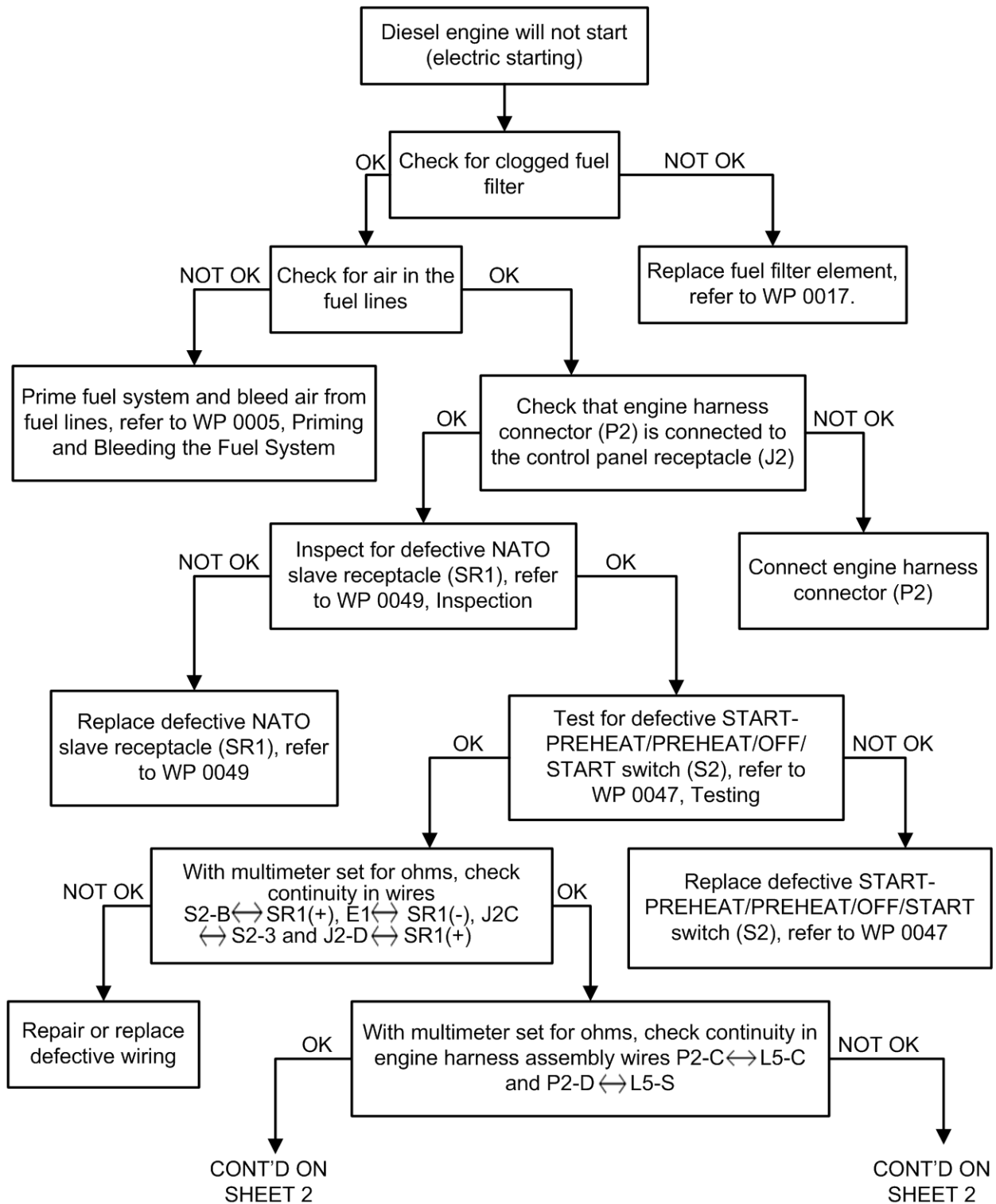

Figure 2. Diesel Engine Will Not Start (Electric Starting) (Sheet 1 of 2).

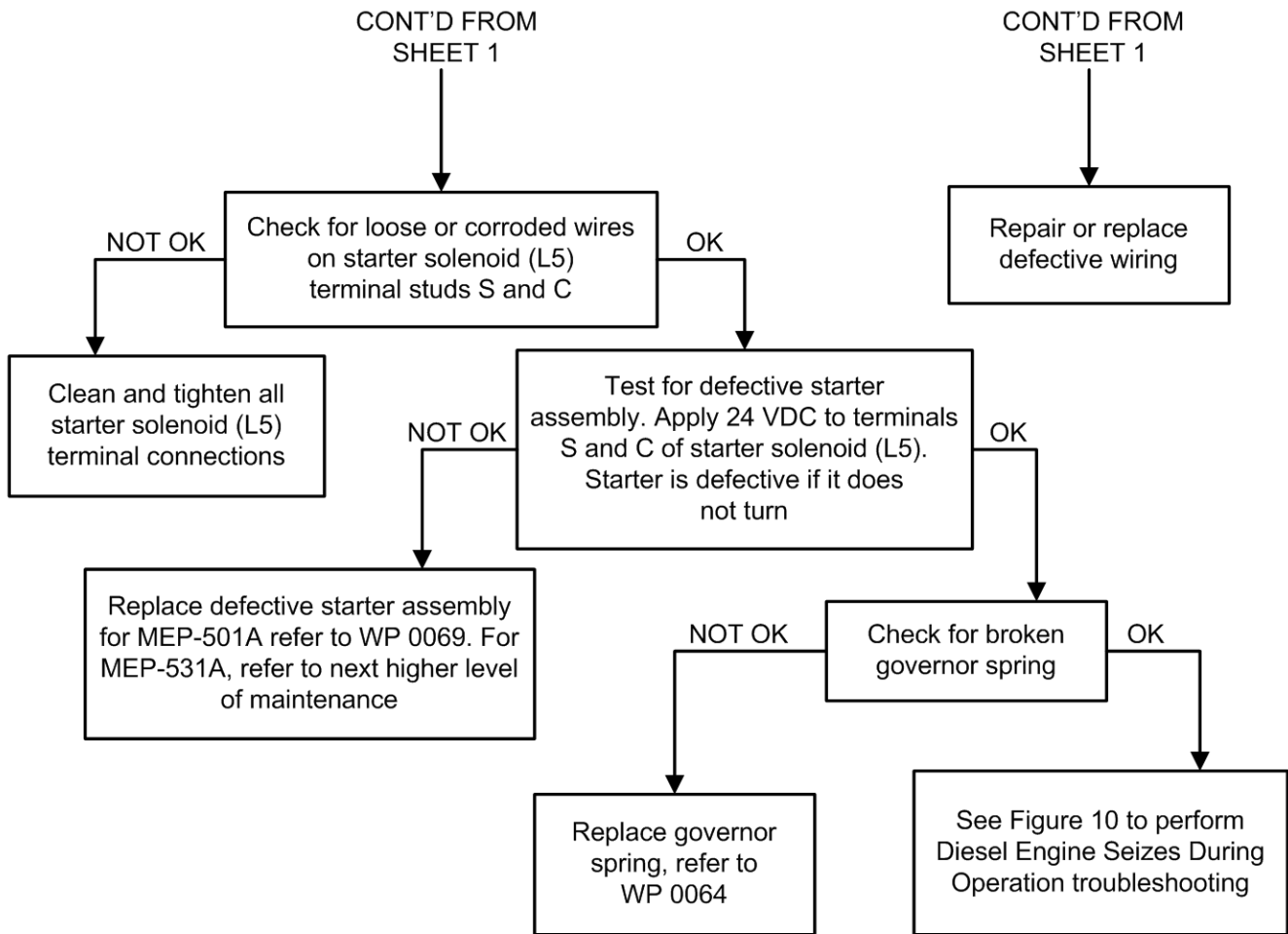

Figure 2. Diesel Engine Will Not Start (Electric Starting) (Sheet 2 of 2).

END OF TASK

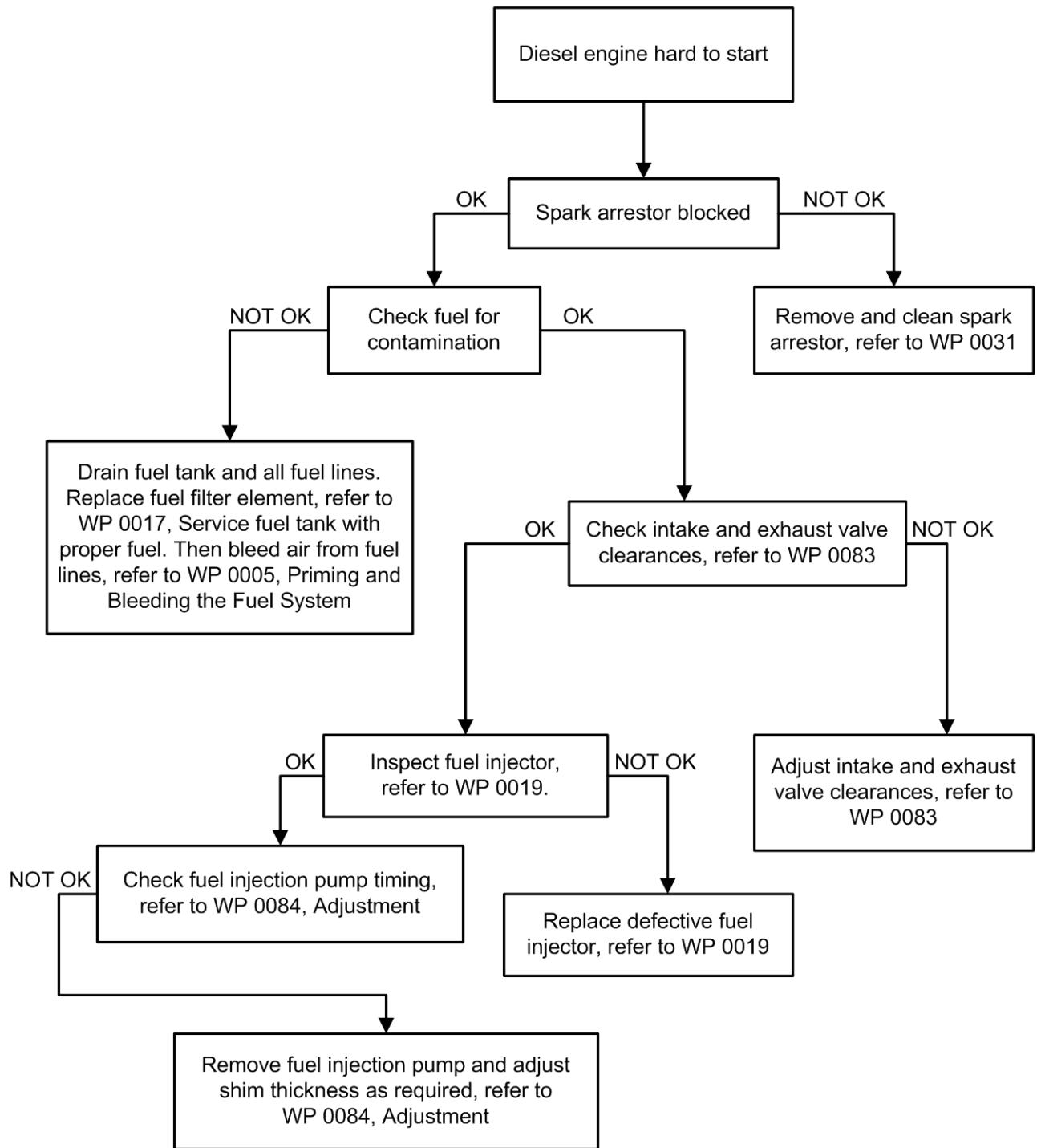

Figure 3. Diesel Engine Hard To Start.

END OF TASK

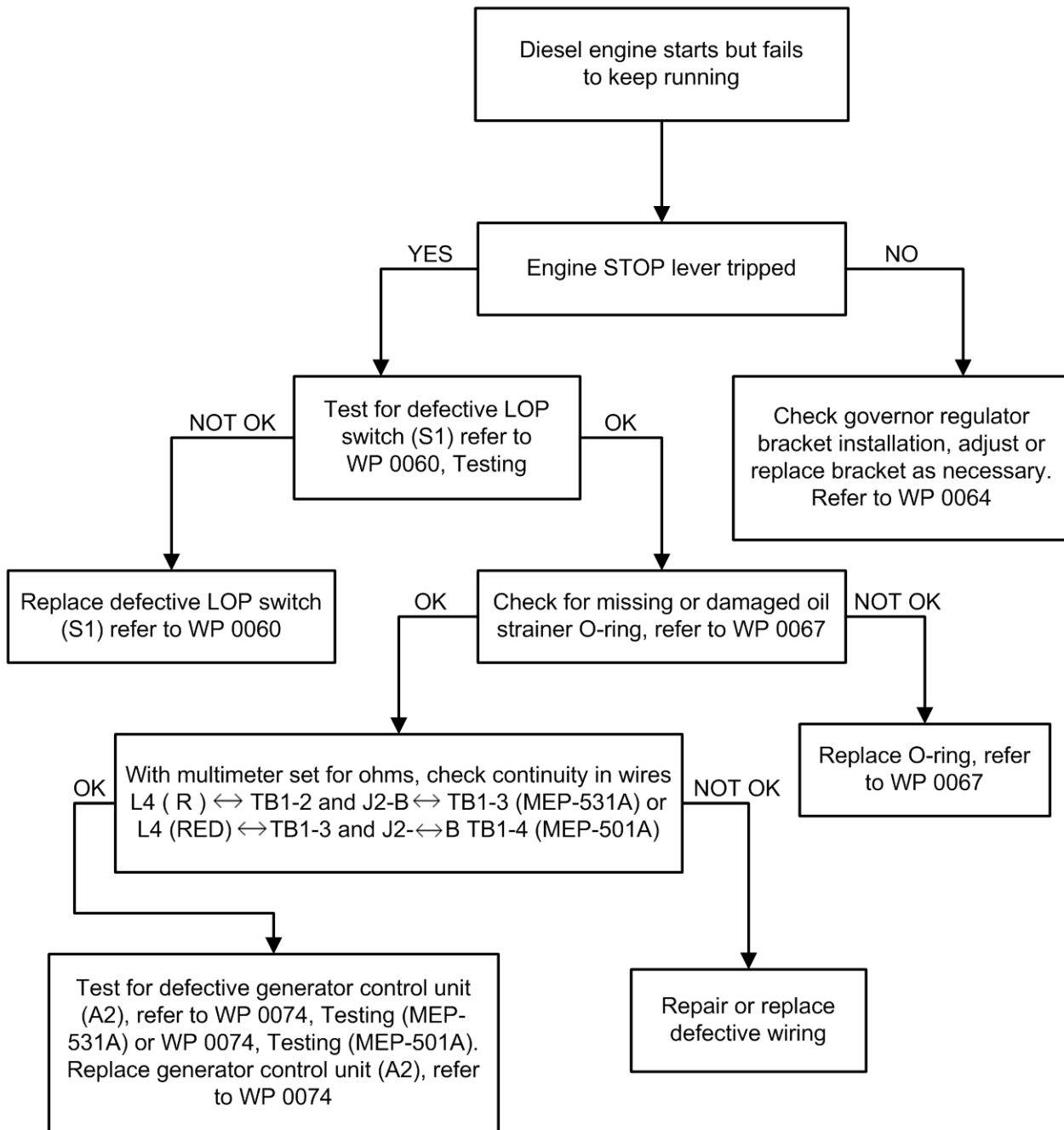

Figure 4. Diesel Engine Starts but Fails to Keep Running.

END OF TASK

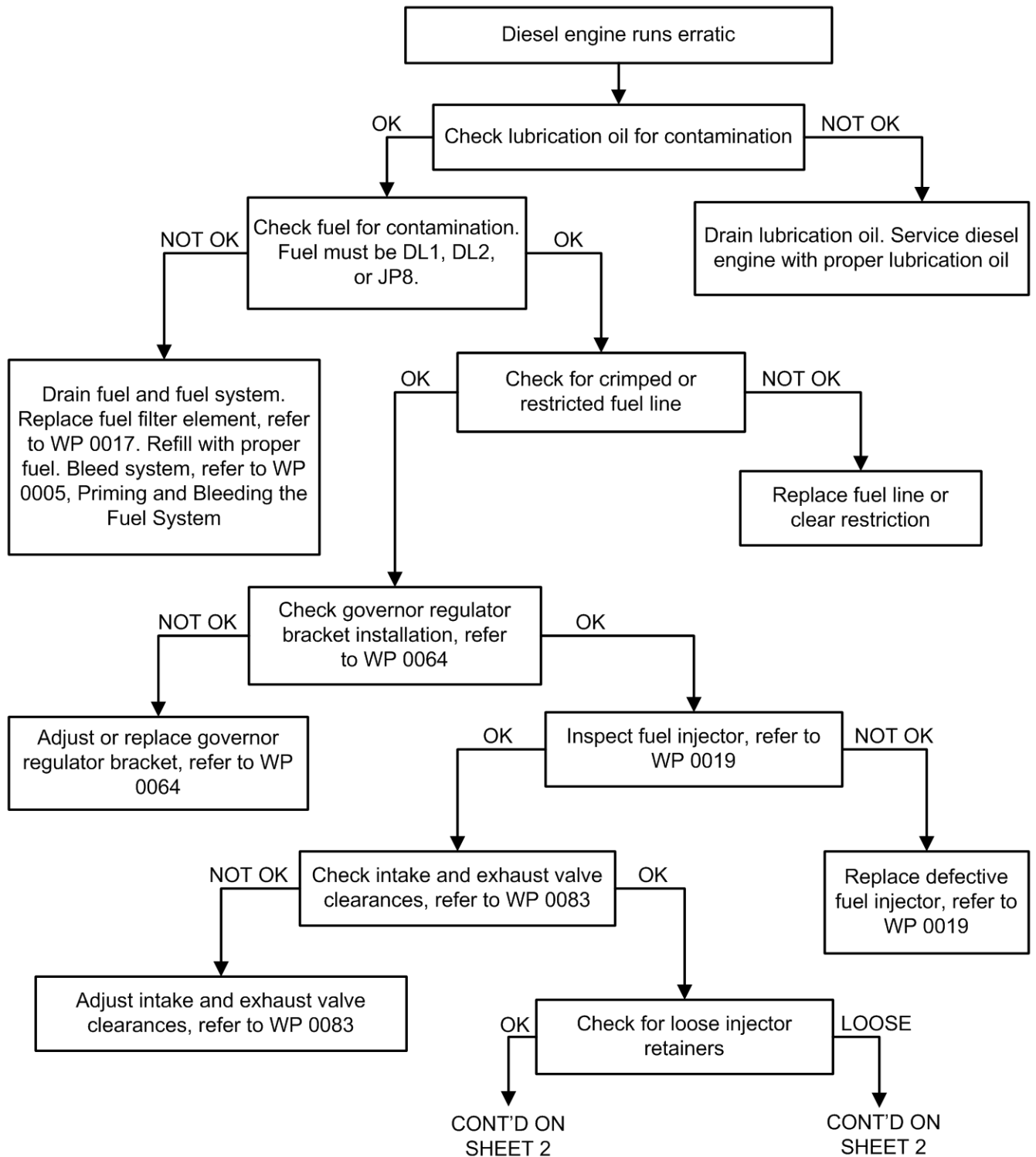

Figure 5. Diesel Engine Runs Erratic (Sheet 1 of 2).

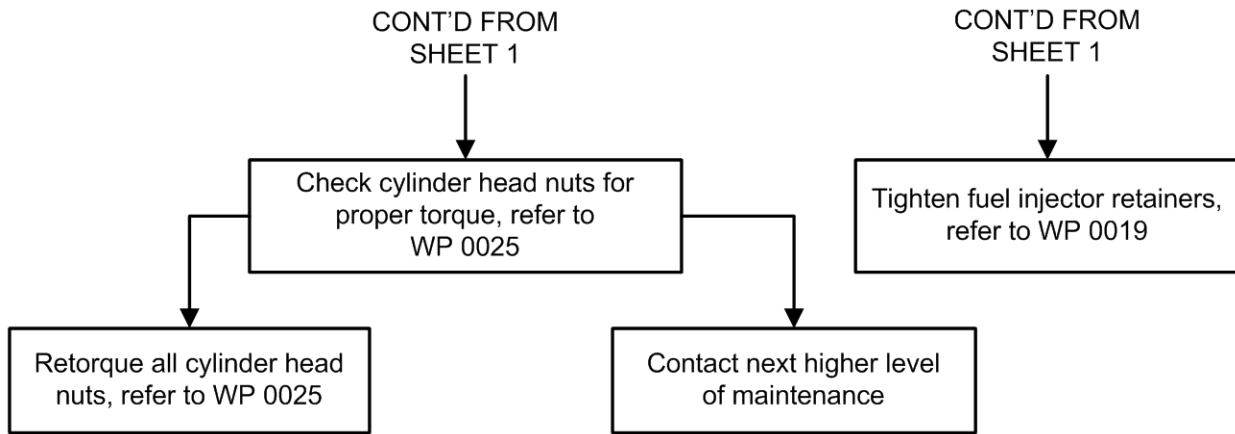

Figure 5. Diesel Engine Runs Erratic (Sheet 2 of 2).

END OF TASK

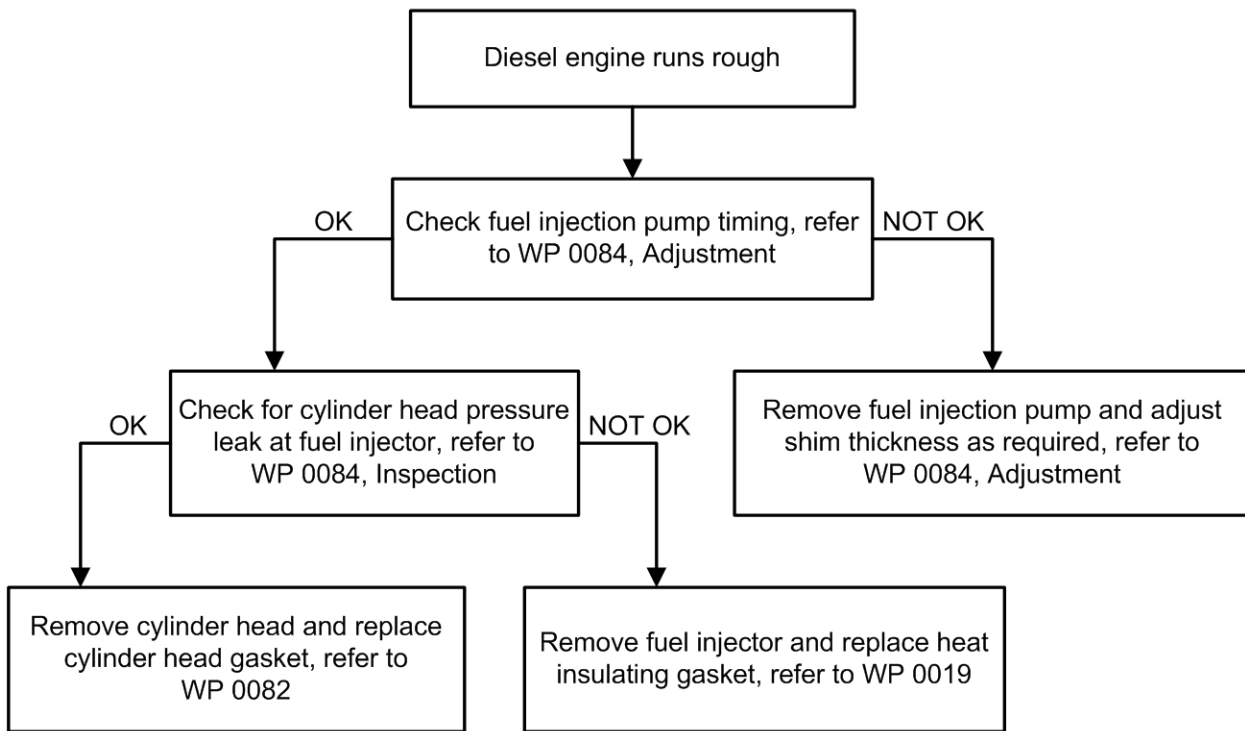

Figure 6. Diesel Engine Runs Rough.

END OF TASK

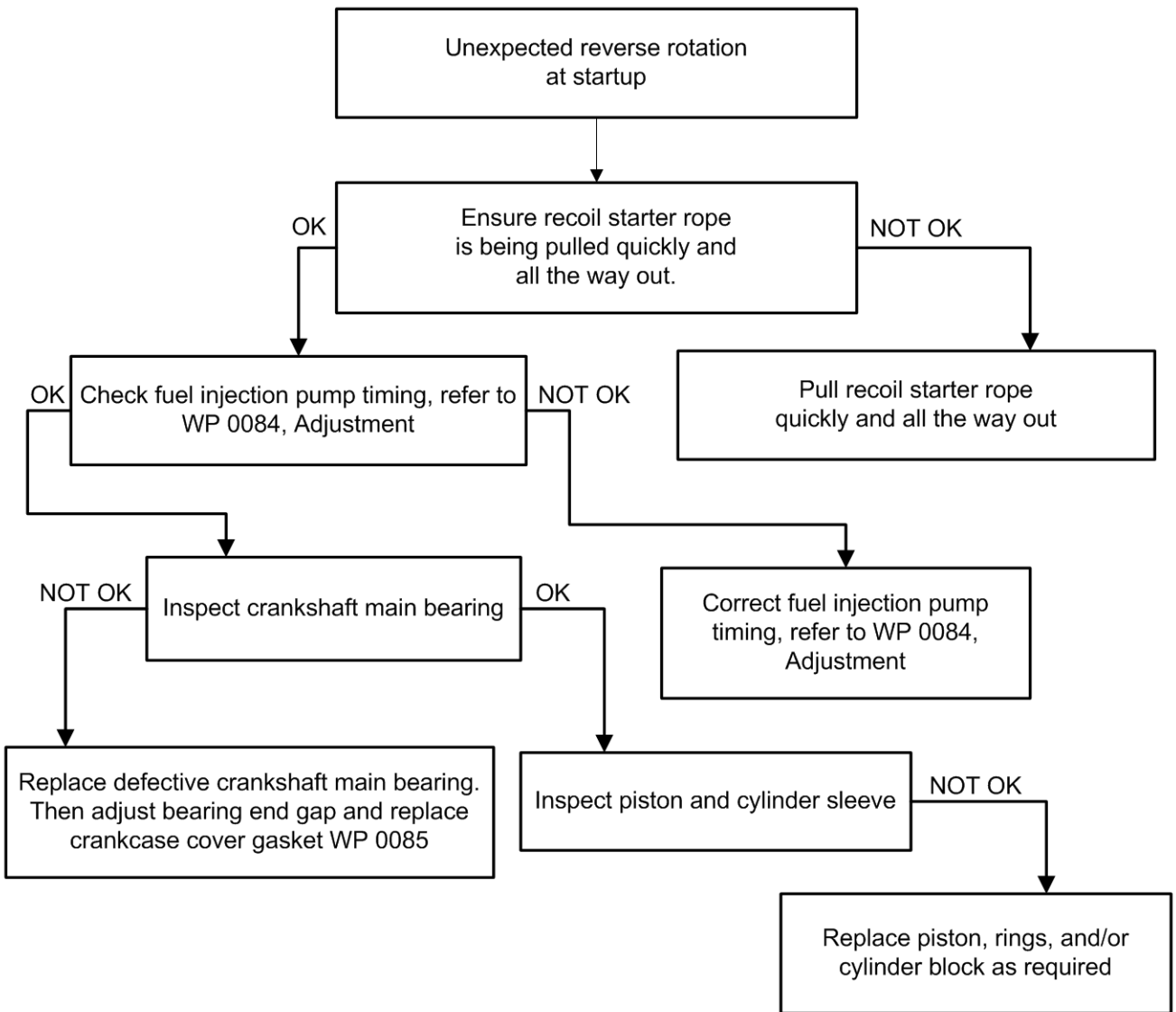

Figure 7. Unexpected Reverse Rotation at Startup.

END OF TASK

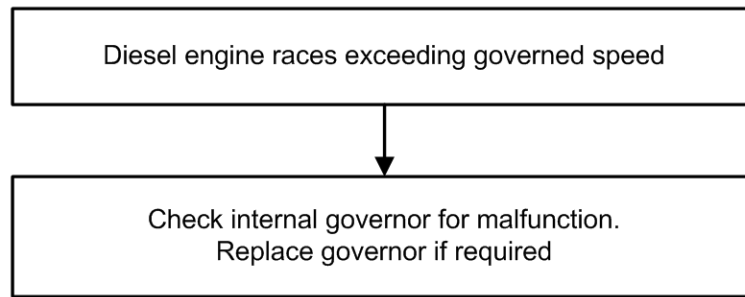

Figure 8. Diesel Engine Races Exceeding Governed Speed.

END OF TASK

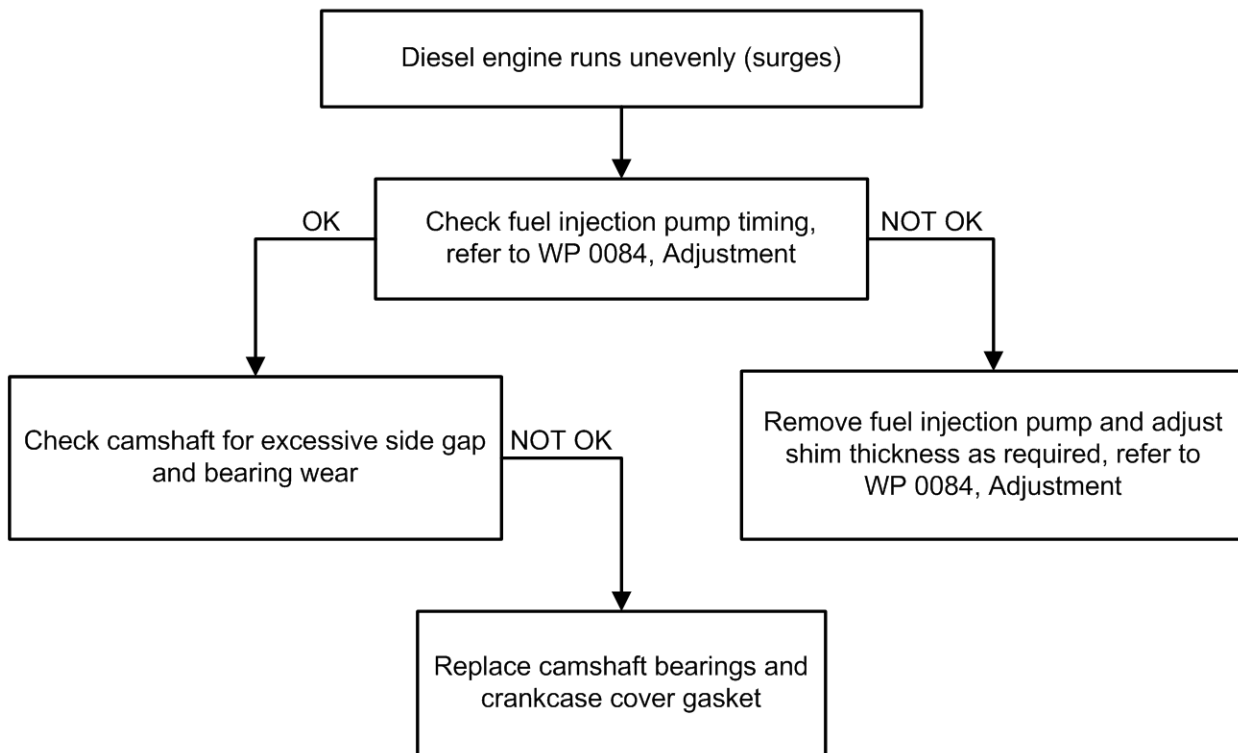

Figure 9. Diesel Engine Runs Unevenly (Surges).

END OF TASK

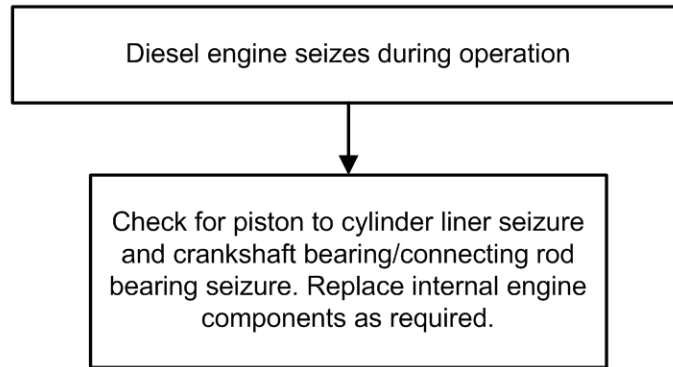

Figure 10. Diesel Engine Seizes During Operation.

END OF TASK

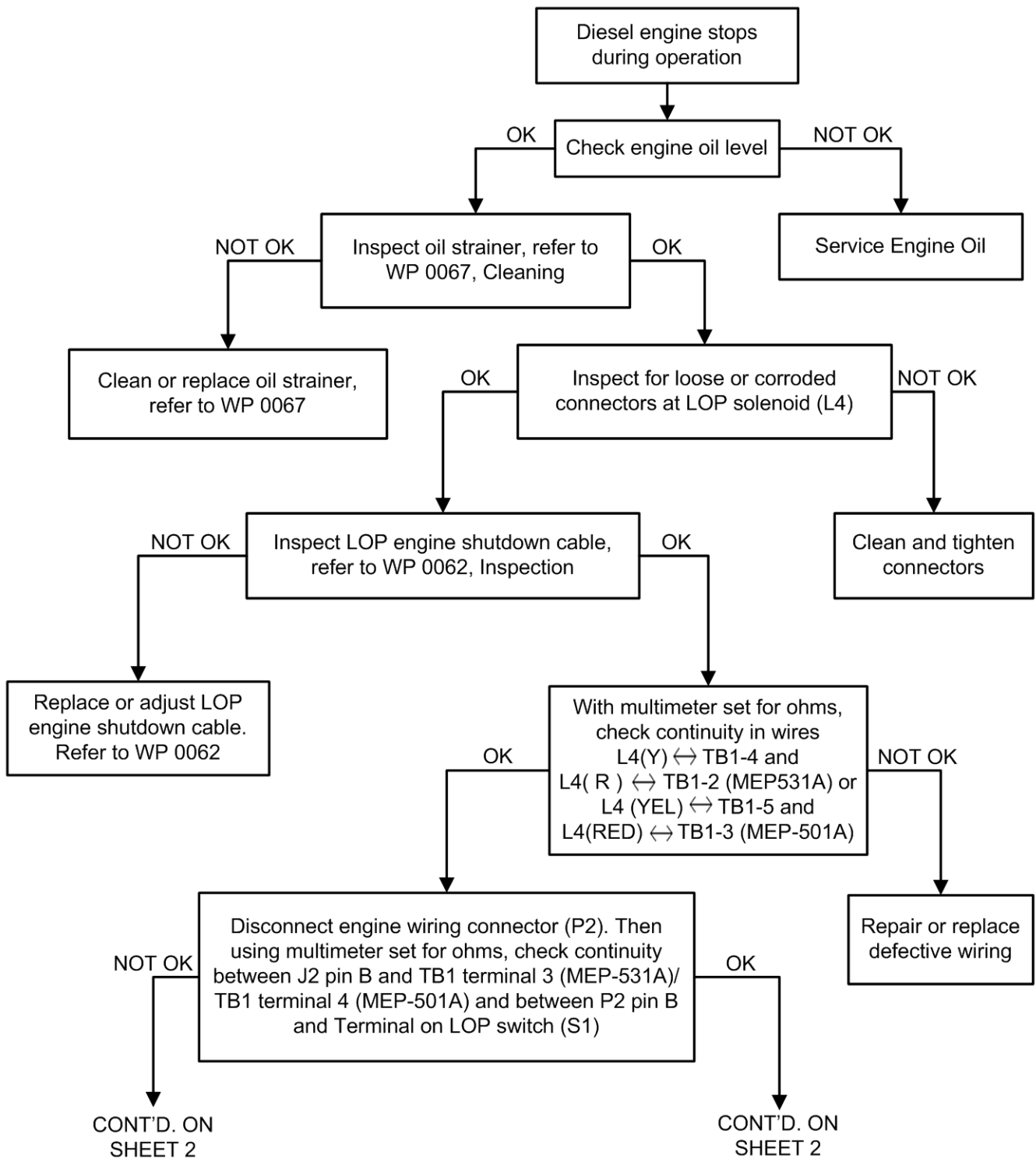

Figure 11. Diesel Engine Stops During Operation (Sheet 1 of 2).

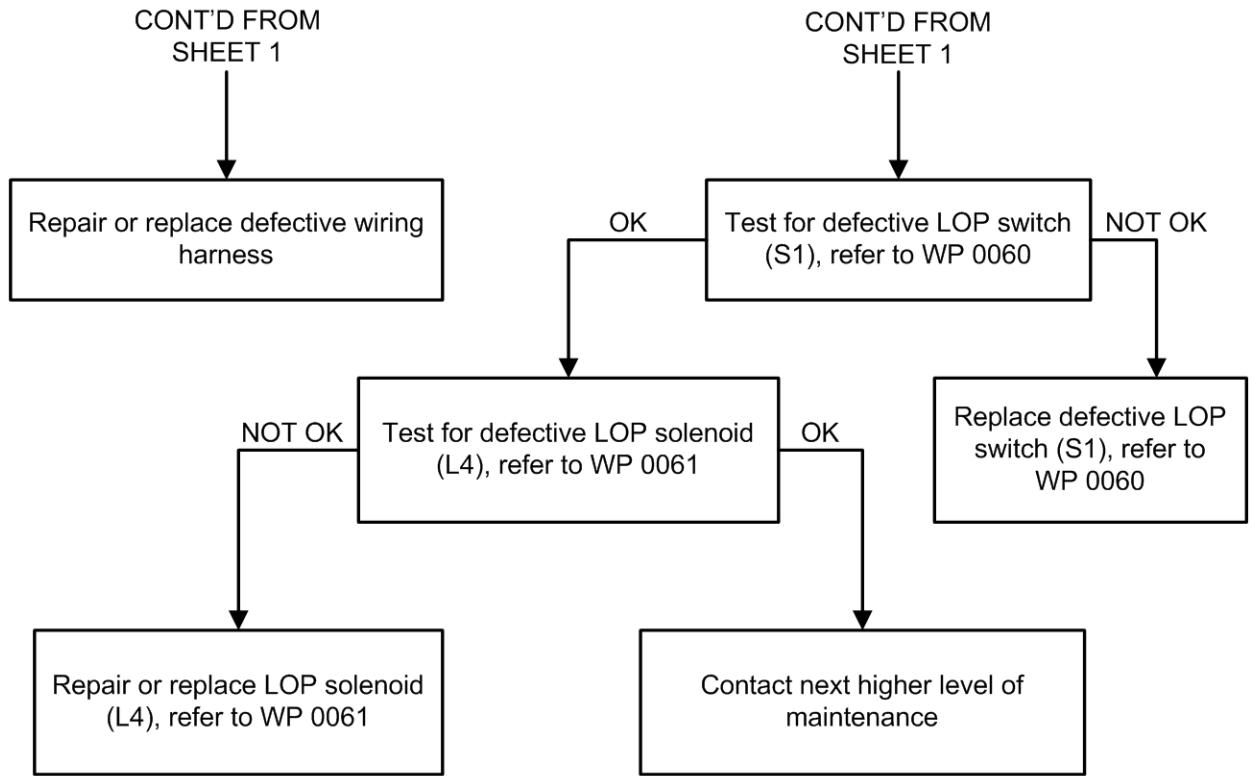

Figure 11. Diesel Engine Stops During Operation (Sheet 2 of 2).

END OF TASK

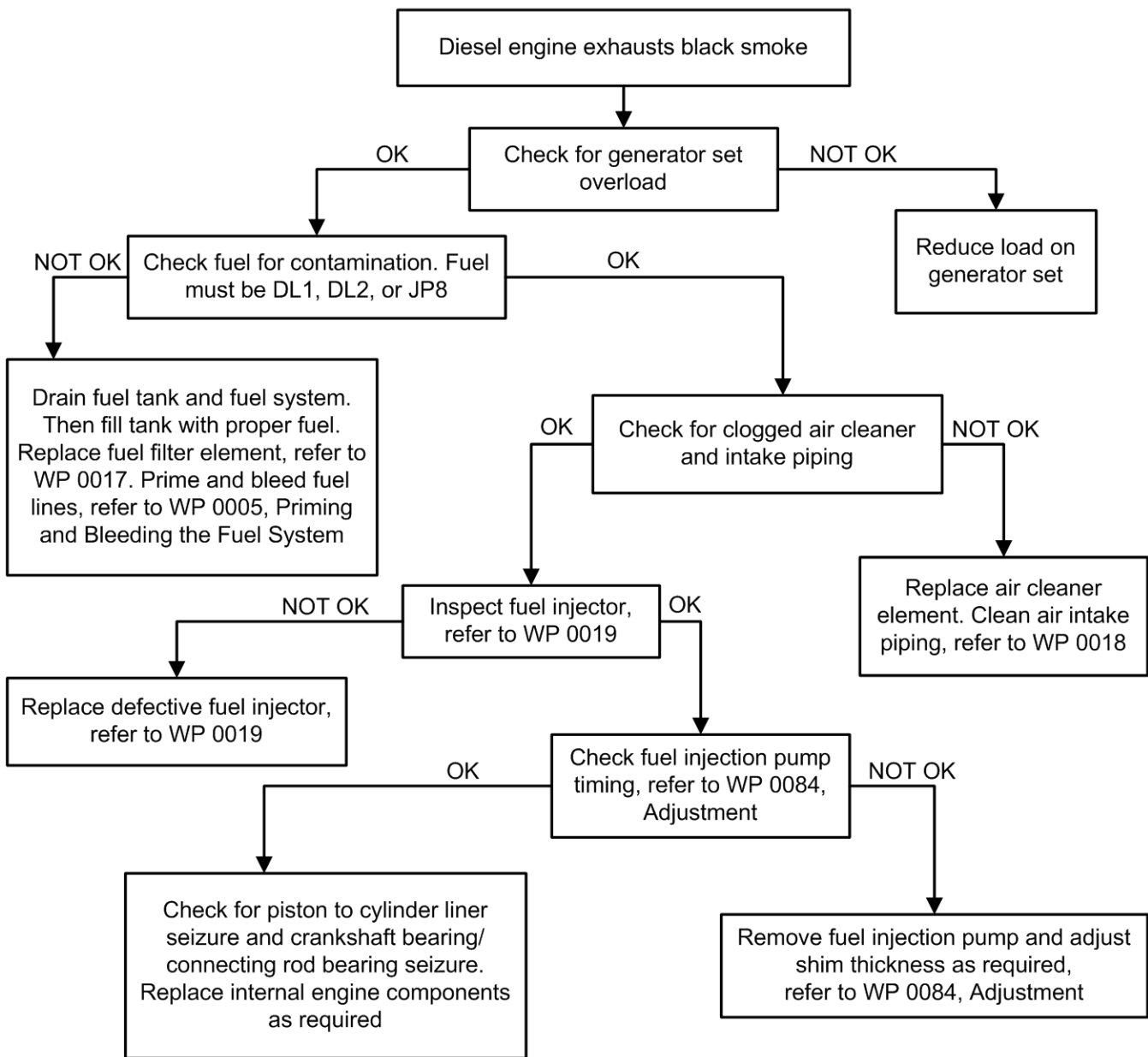

Figure 12. Diesel Engine Exhausts Black Smoke.

END OF TASK

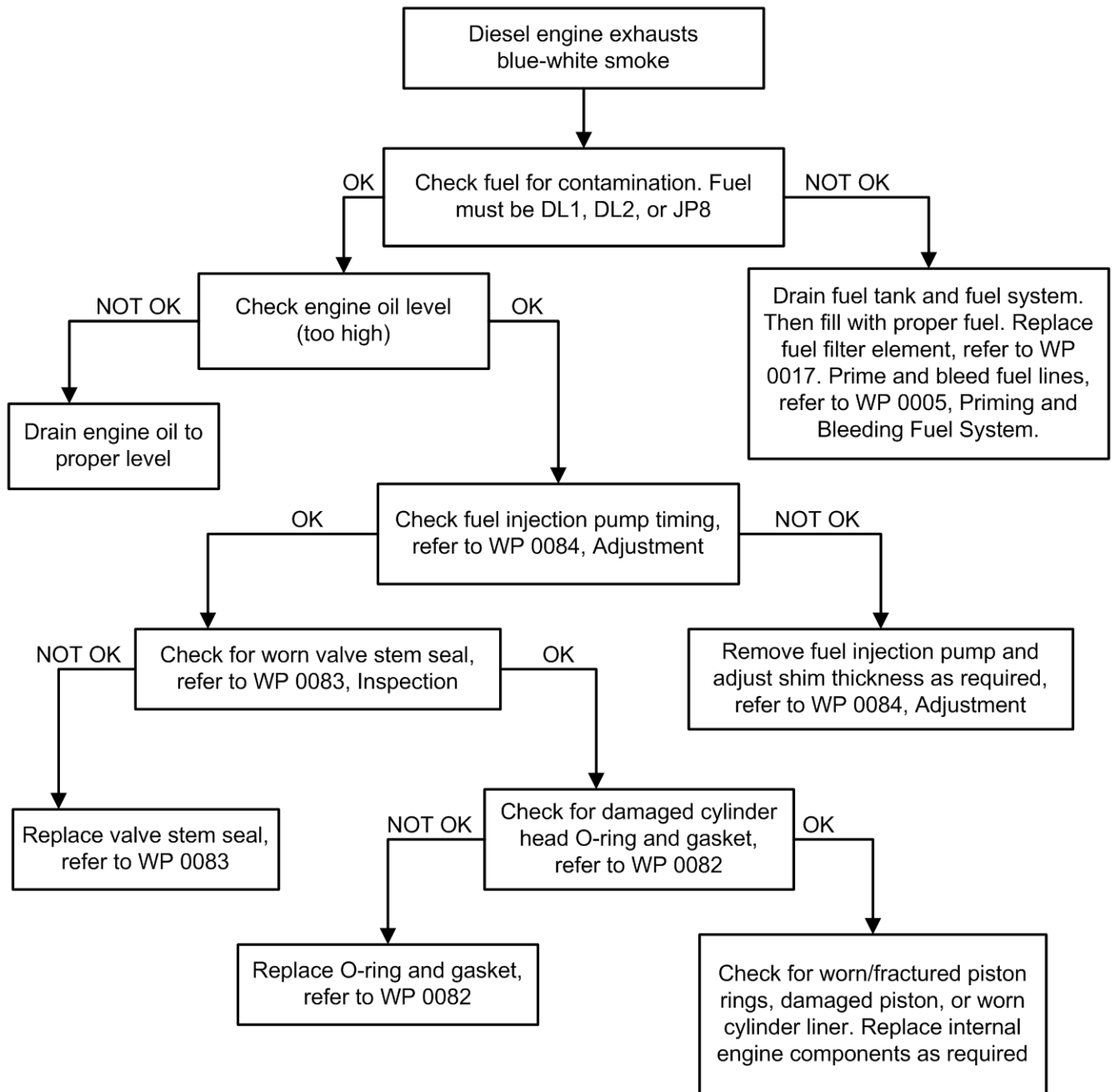

Figure 13. Diesel Engine Exhausts Blue-White Smoke.

END OF TASK

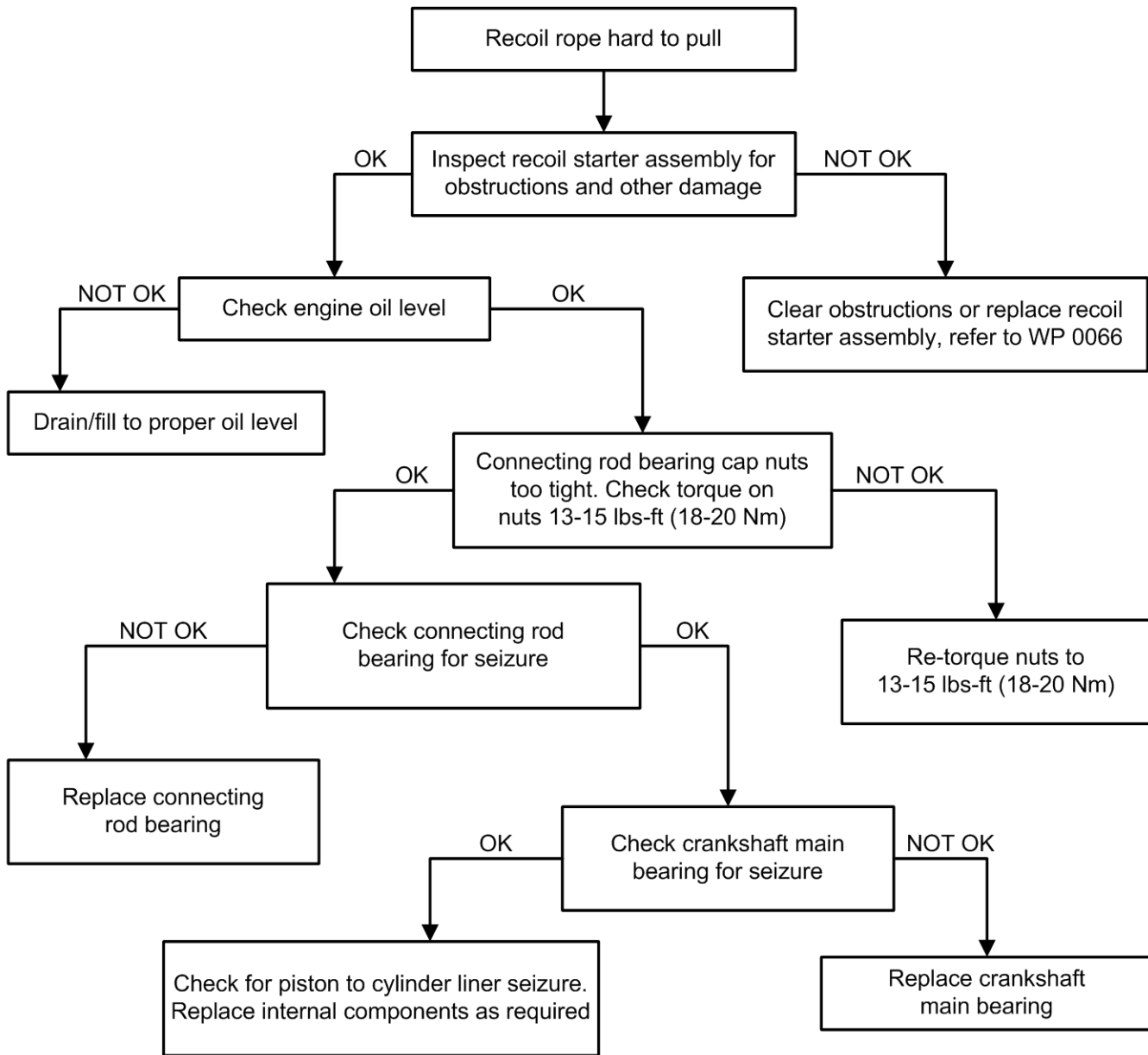

Figure 14. Recoil Start Rope Hard to Pull.

END OF TASK

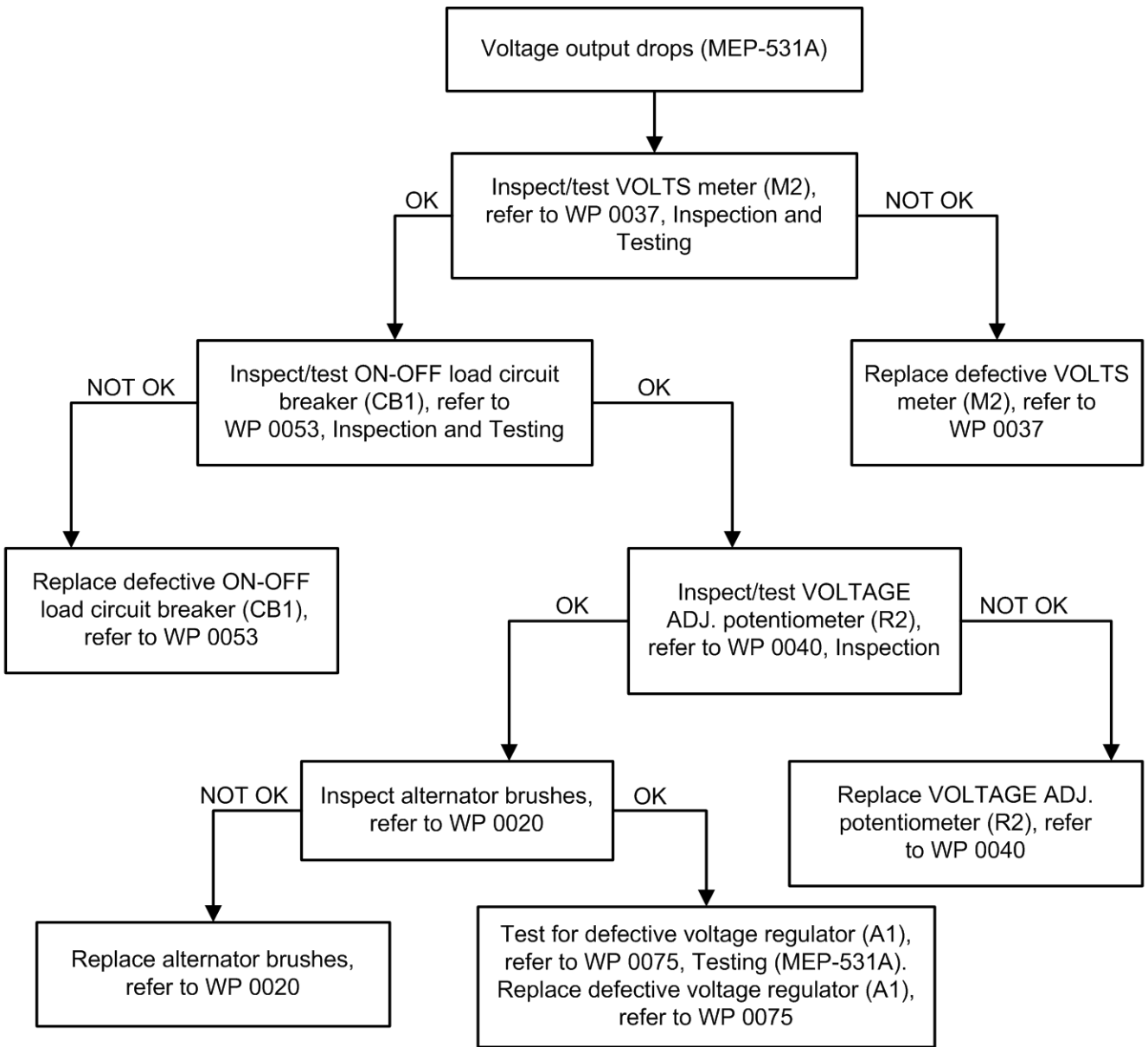

Figure 15. Voltage Output Drops (MEP-531A).

END OF TASK

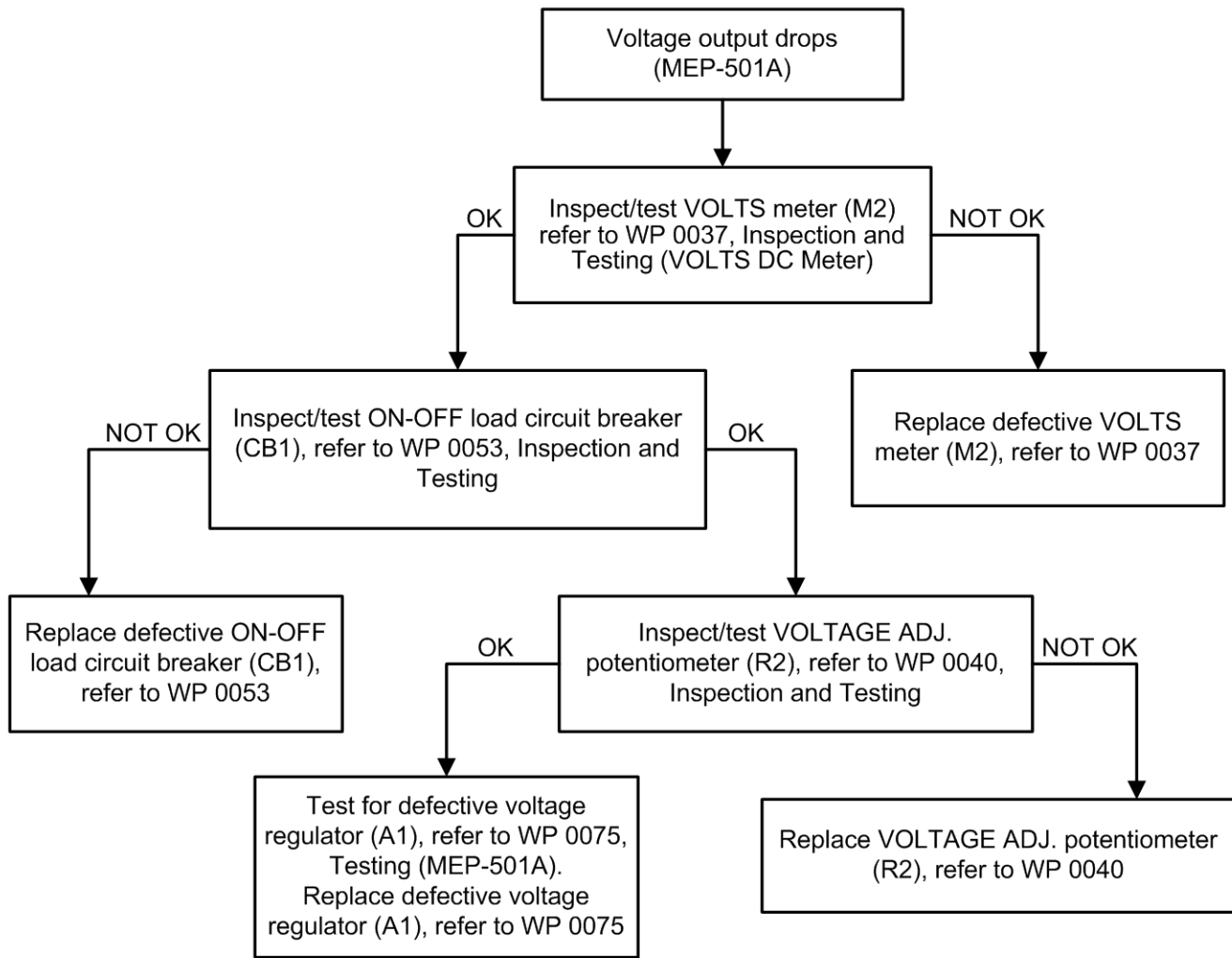

Figure 16. Voltage Output Drops (MEP-501A).

END OF TASK

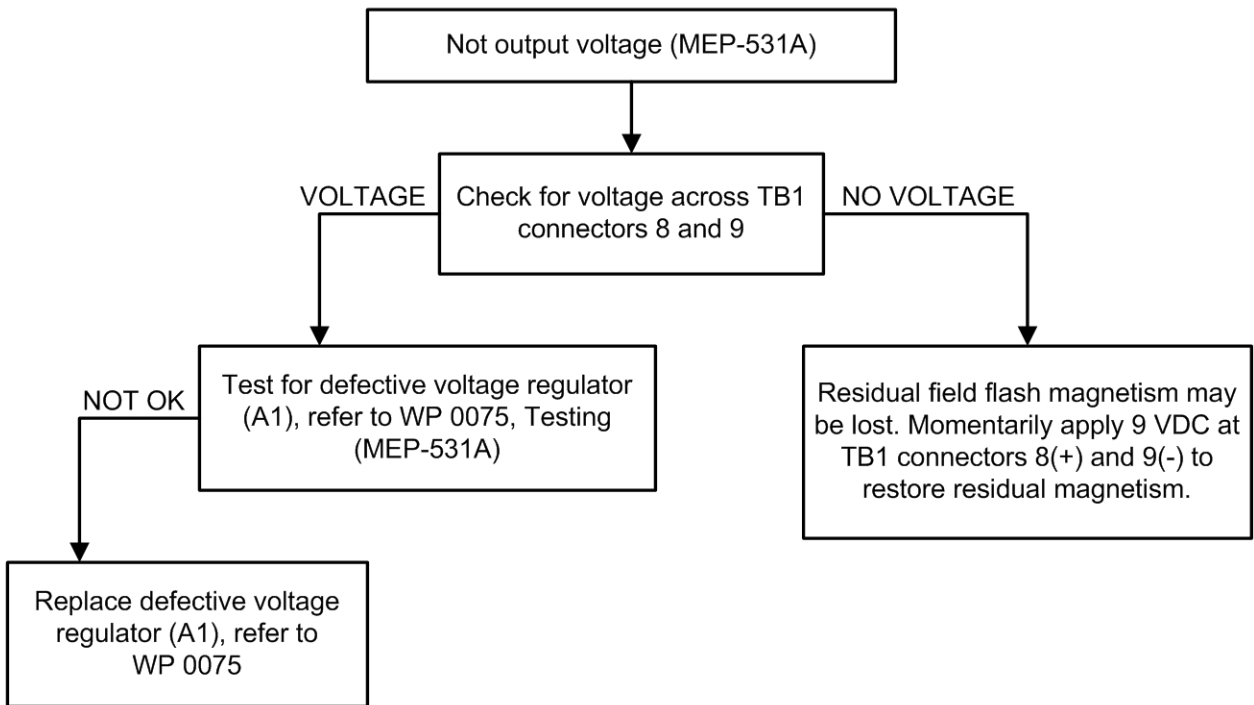

Figure 17. No Output Voltage (MEP-531A).

END OF TASK

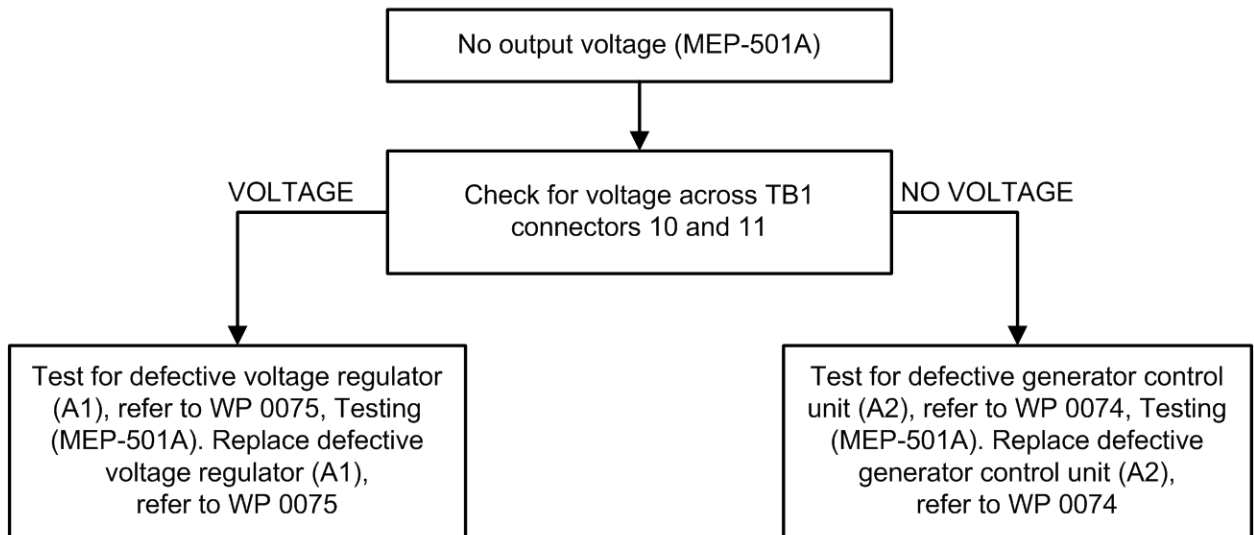

Figure 18. No Output Voltage (MEP-501A).

END OF TASK

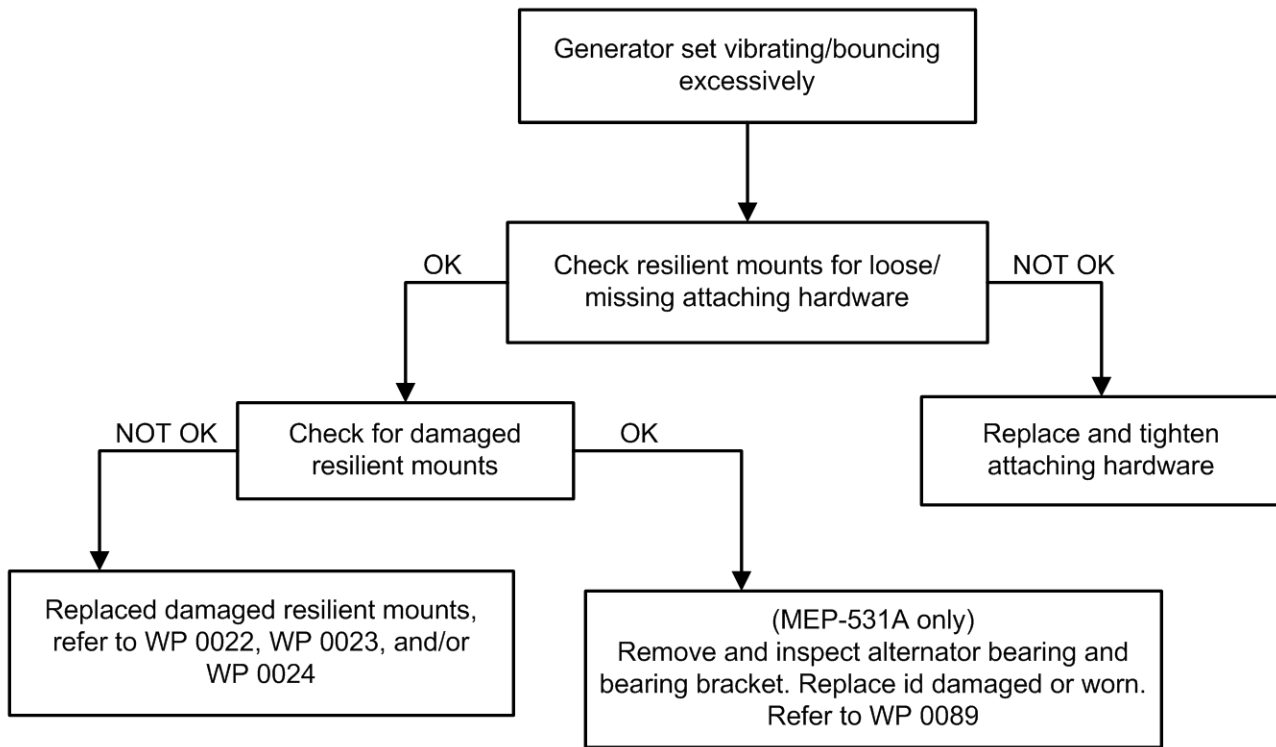

Figure 19. Generator Set Vibrating/Bouncing Excessively.

END OF TASK

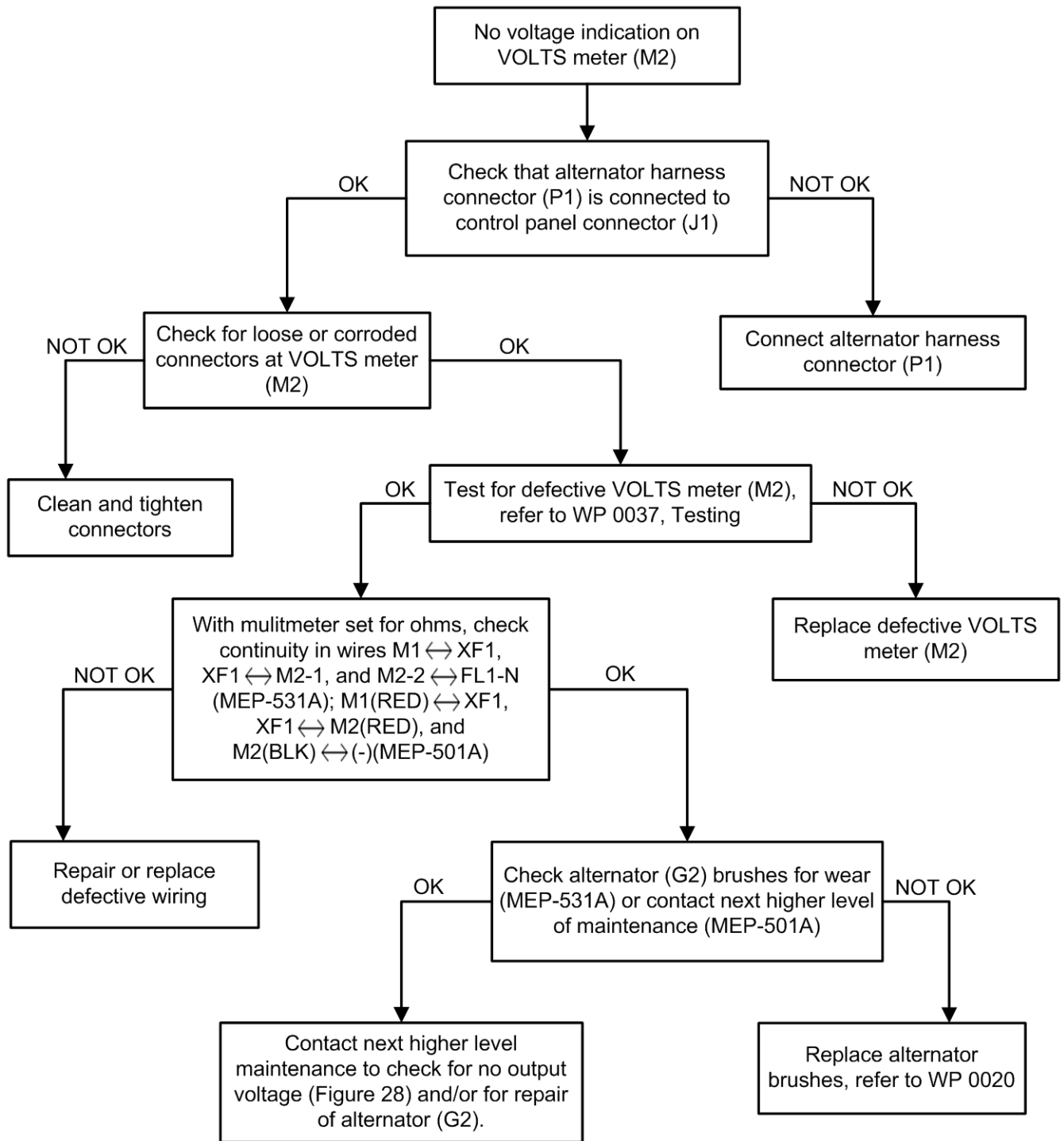

Figure 20. No Voltage Indication on VOLTS Meter (M2).

END OF TASK

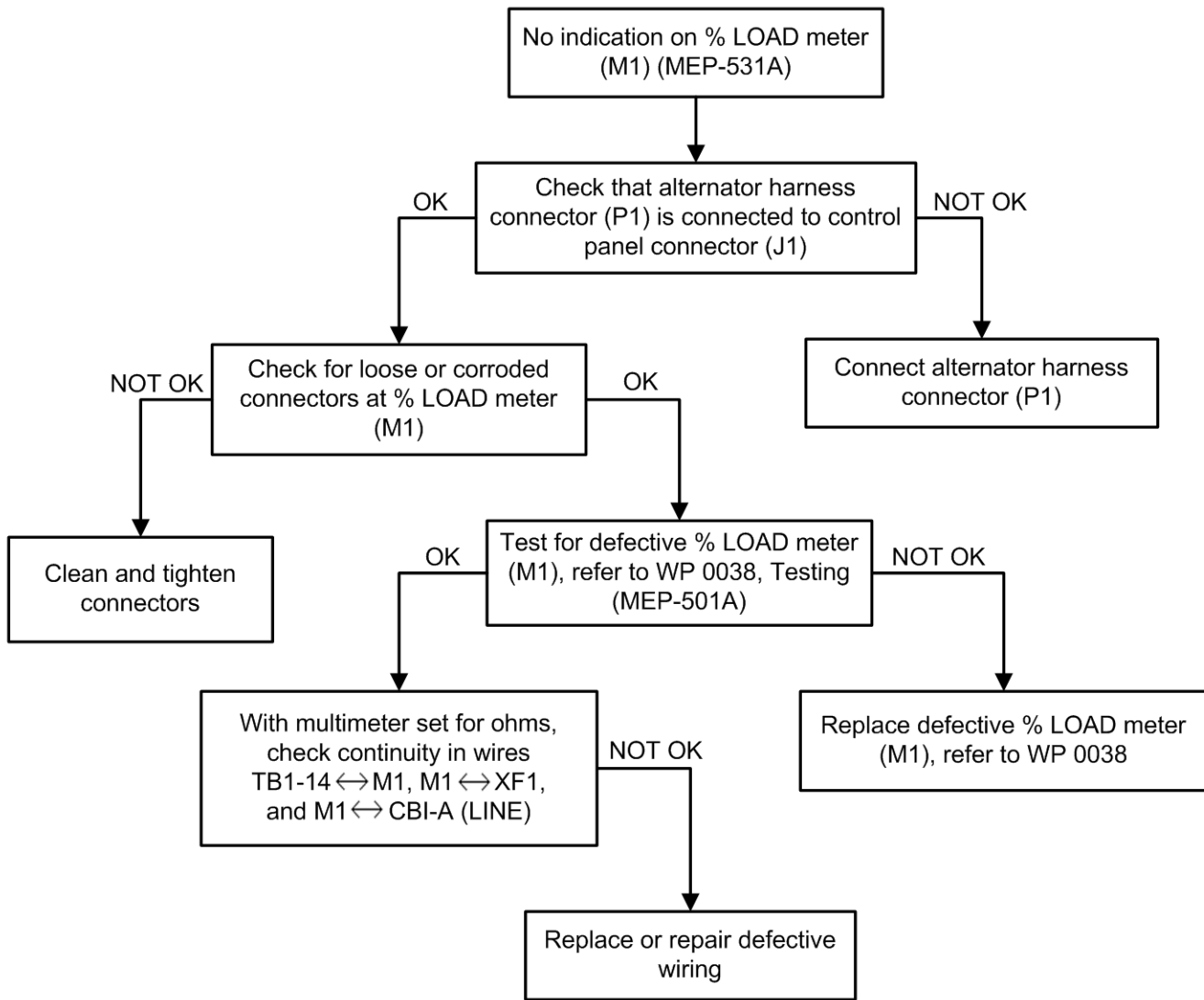

Figure 21. No Indication on % LOAD Meter (M1) (MEP-531A).

END OF TASK

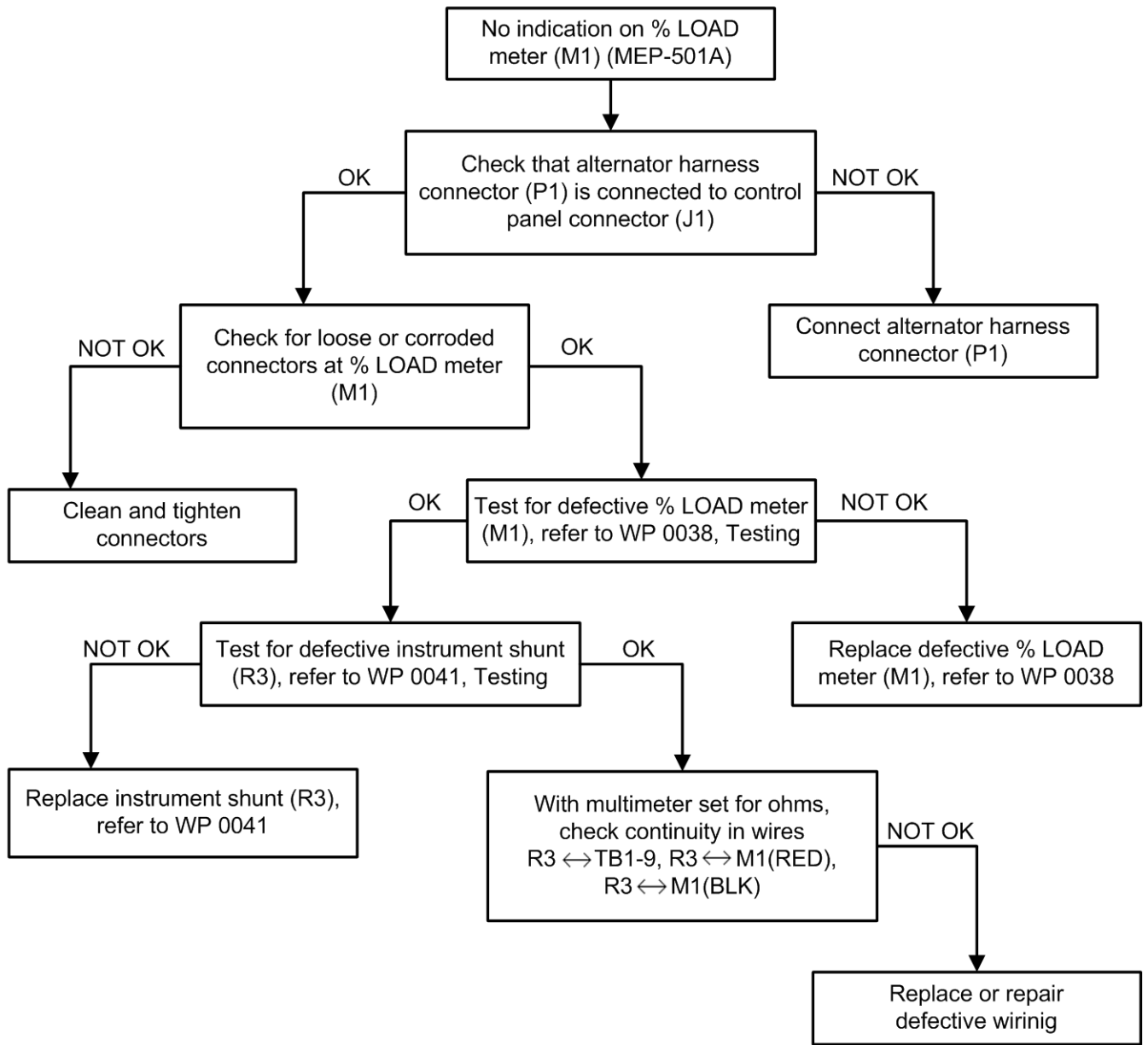

Figure 22. No Indication on % LOAD Meter (M1) (MEP-501A).

END OF TASK

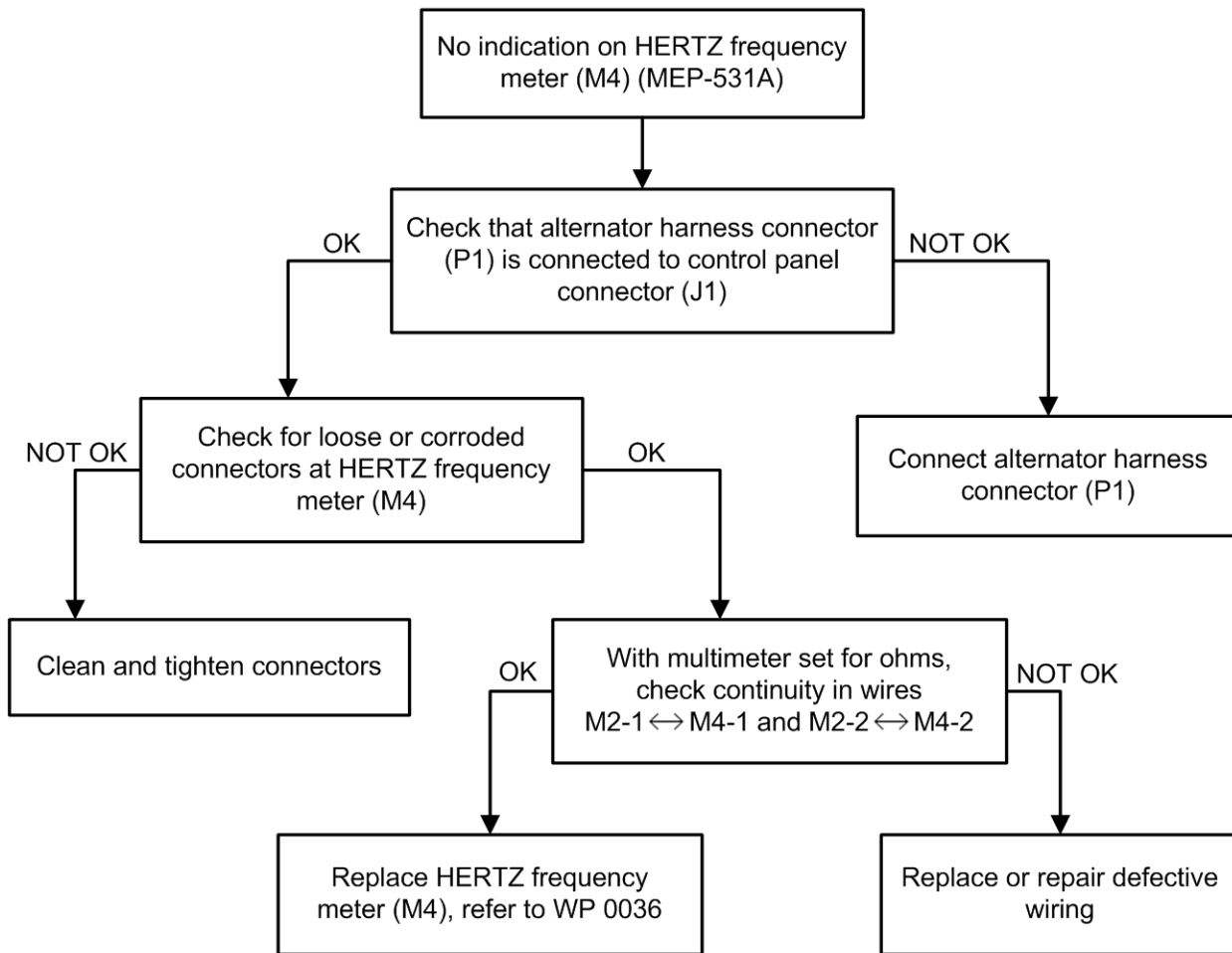

Figure 23. No Indication on HERTZ Frequency Meter (M4) (MEP-531A).

END OF TASK

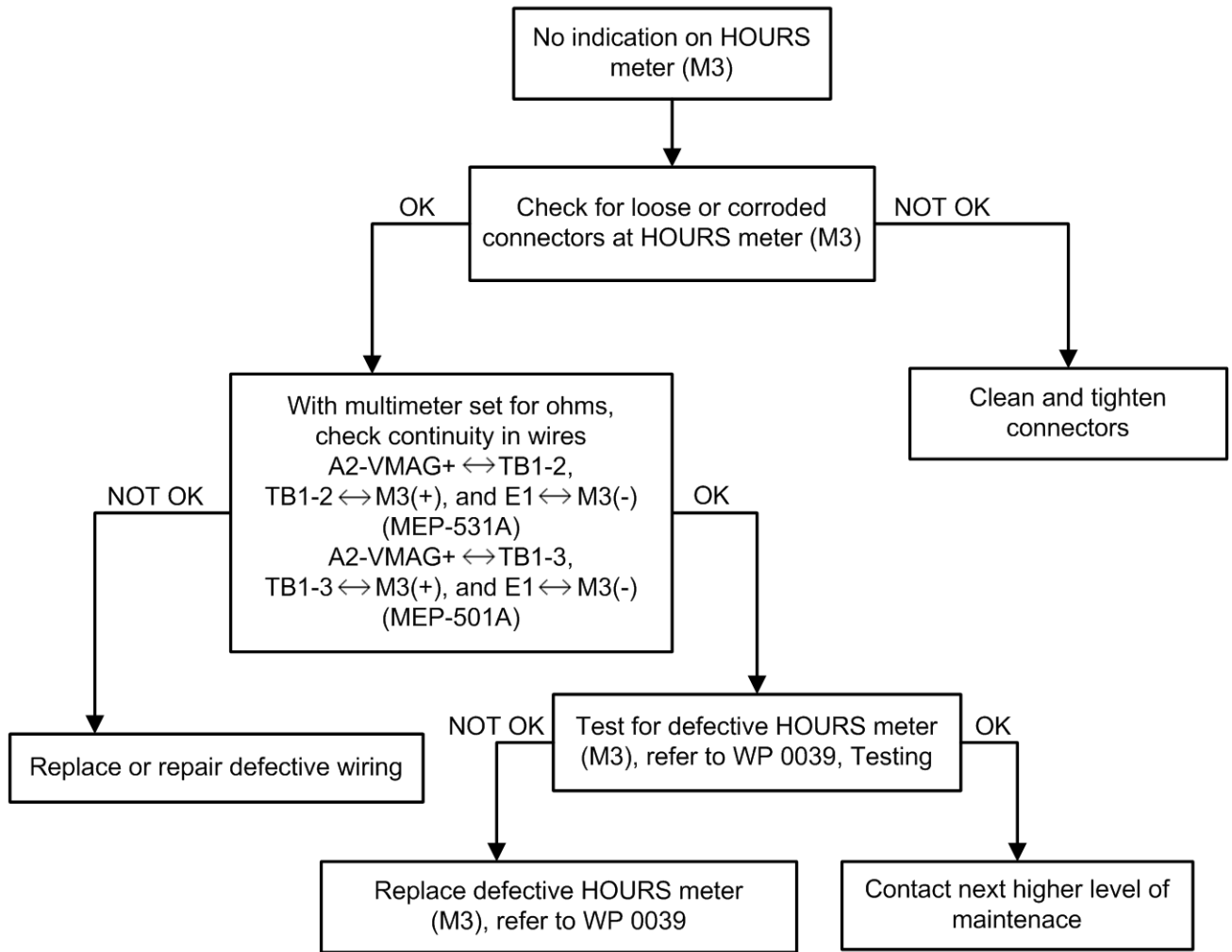

Figure 24. No Indication on HOURS Meter (M3).

END OF TASK

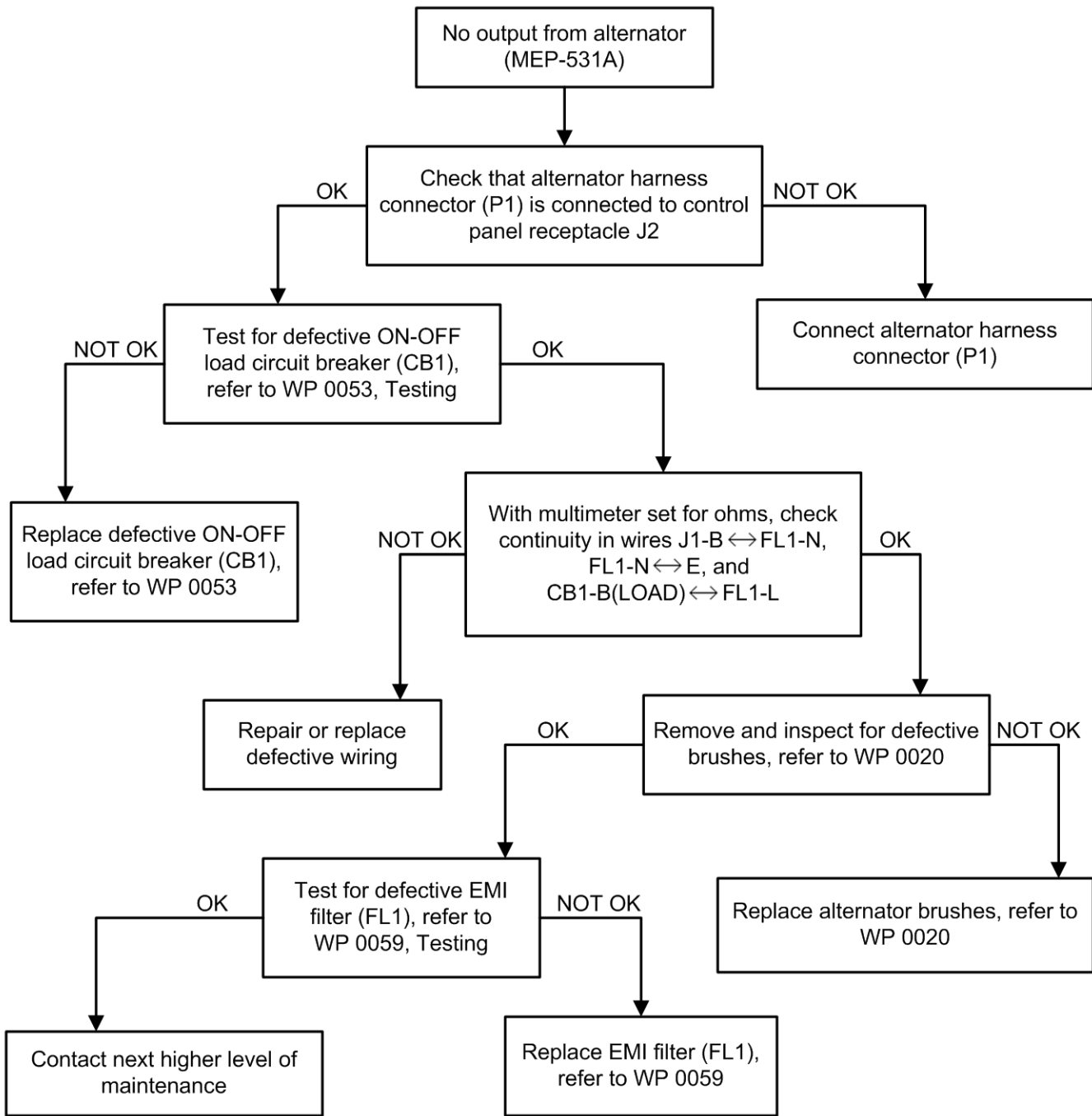

Figure 25. No Output from Alternator (MEP-531A).

END OF TASK

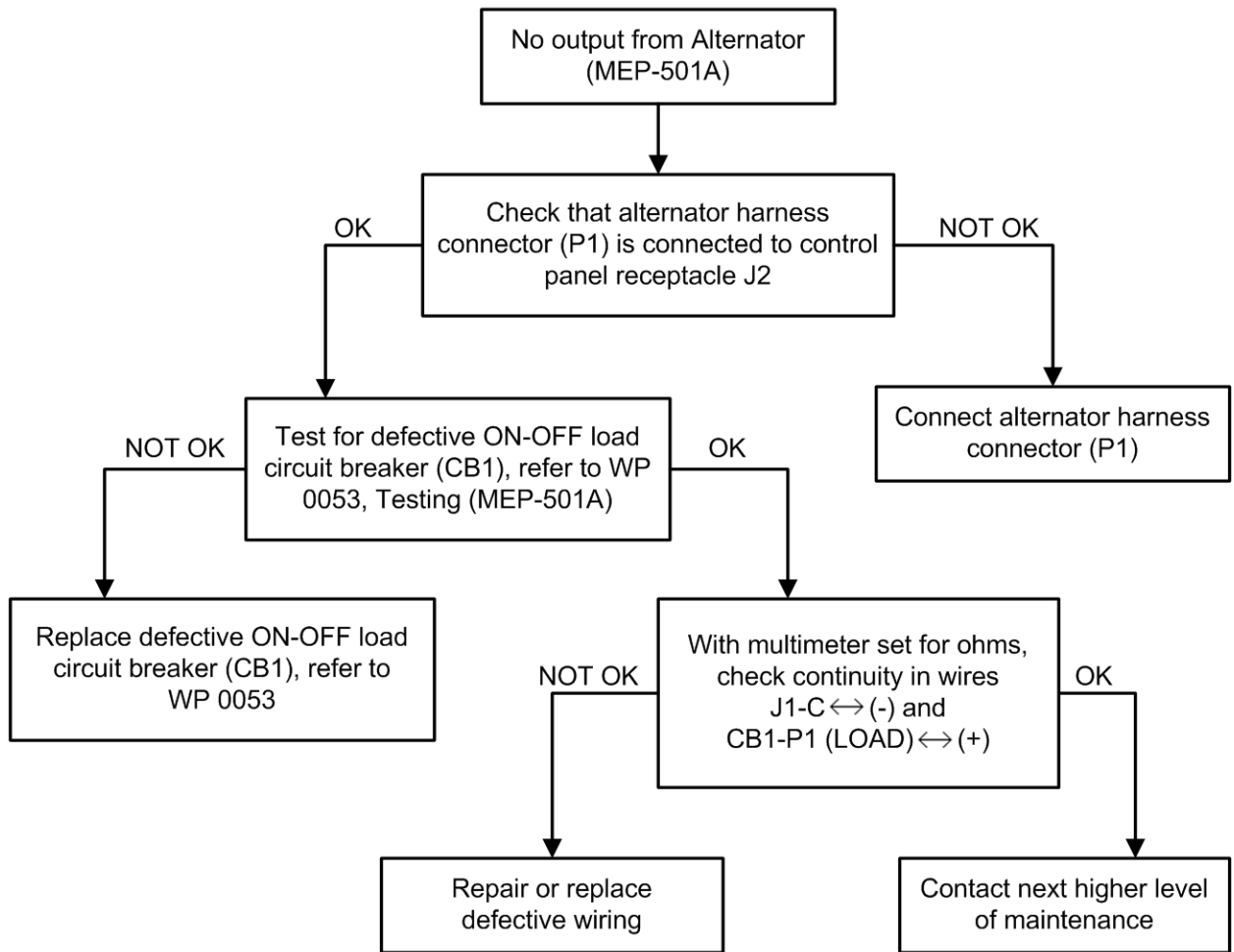

Figure 26. No Output from Alternator (MEP-501A).

END OF TASK

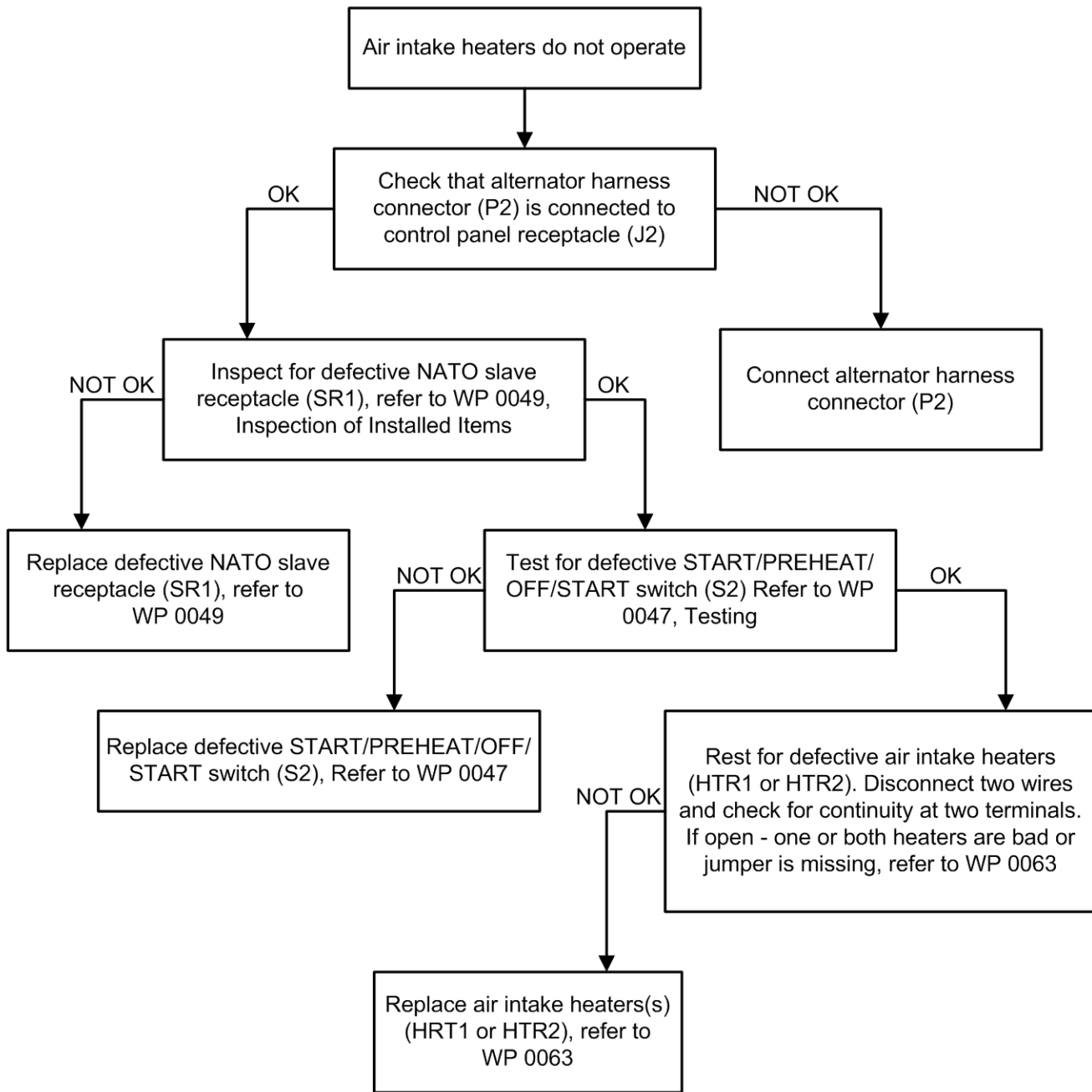

Figure 27. Air Intake Preheaters Do Not Operate.

END OF TASK

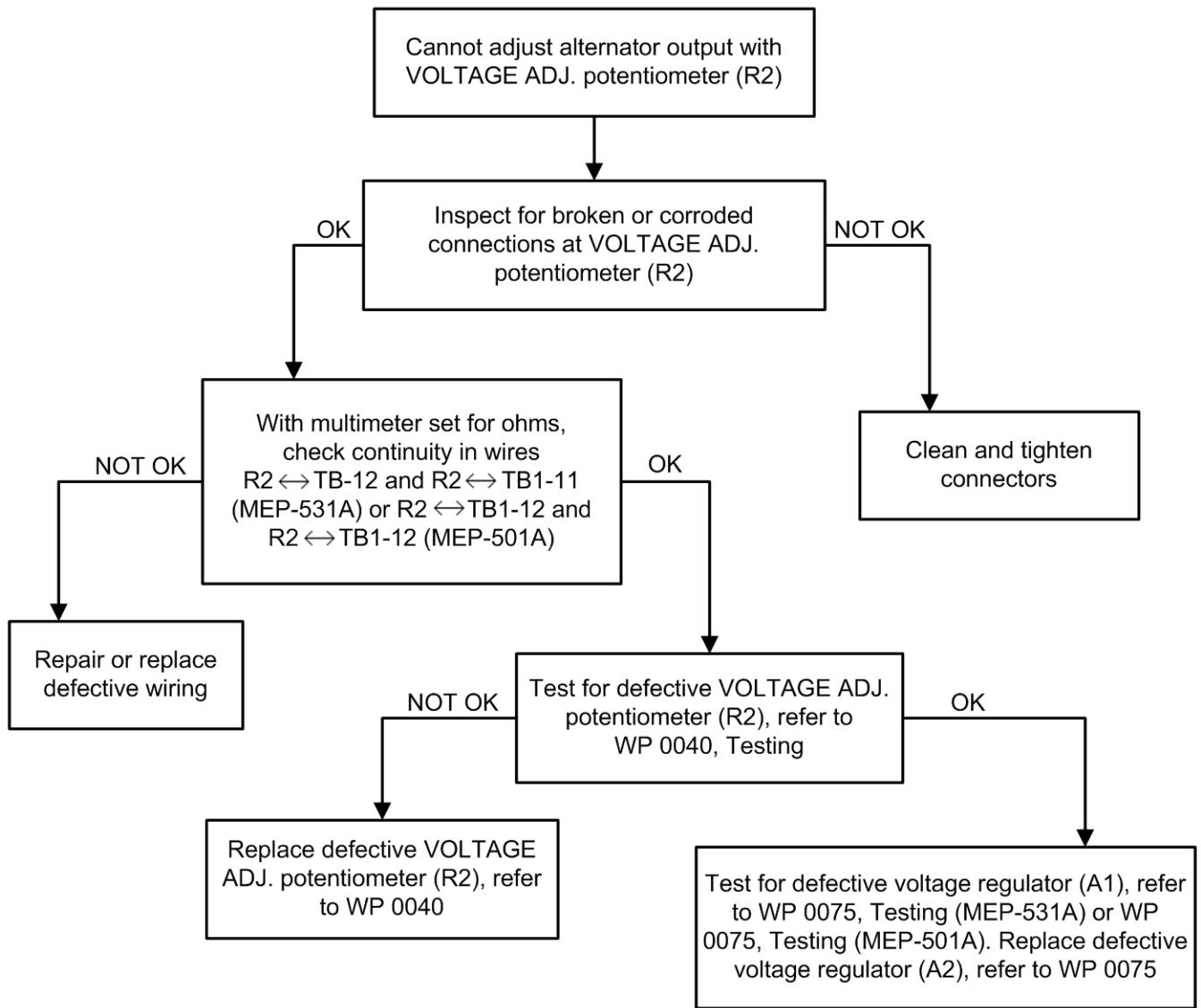

Figure 28. Cannot Adjust Alternator Output With VOLTAGE ADJ. Potentiometer.

END OF TASK

END OF WORK PACKAGE

CHAPTER 6

FIELD MAINTENANCE INSTRUCTIONS

FOR

2 kW MILITARY TACTICAL GENERATOR SETS

MEP-531A

MEP-501A

CHAPTER 6

FIELD MAINTENANCE INSTRUCTIONS

WORK PACKAGE INDEX

<u>Title</u>	<u>WP Sequence No.</u>
Service Upon Receipt.....	0014
Field PMCS Introduction.....	0015
Field PMCS, Including Lubrication Instructions	0016
Fuel Filter Element Replacement	0017
Air Filter Element Replacement.....	0018
Fuel Injector Replacement.....	0019
Alternator Brushes Inspection (MEP-531A).....	0020
Alternator Flexible Coupling Inspection (MEP-501A)	0021
Engine Resilient Mounts Replacement.....	0022
Alternator Resilient Mount Replacement (MEP-531A)	0023
Alternator Resilient Mount Replacement (MEP-501A)	0024
Cylinder Head Nuts Tightening.....	0025
Fuel Lines, Clamps, Fittings, Etc	0026
Fuel Filter Assembly	0027
Fuel Drain Cock.....	0028
Fuel Tank Assembly	0029
Air Intake System Components	0030
Exhaust System Components	0031
Control Panel Assembly	0032
Instruction Plate(s).....	0033
Instrument Cover	0034
Instrument Panel	0035
Hertz Frequency Meter (MEP-531A)	0036
Volts Meter	0037
% Load Meter	0038
HOURS Meter	0039
VOLTAGE ADJ. Potentiometer	0040
Instrument Shunt (MEP-501A)	0041
Capacitor (MEP-501A)	0042
Transient Suppressor Assembly (MEP-501A).....	0043
Fuseholder(s)	0044
Ground Strap(s).....	0045
GFCI Receptacle and Receptacle Cover (MEP-531A).....	0046

<u>Title</u>	<u>WP Sequence No.</u>
START-PREHEAT/PREHEAT/OFF/START Rotary Switch	0047
Discharge Varistor	0048
NATO Slave Receptacle.....	0049
Load Terminal(s) (MEP-501A and Mechron Sets)	0050
Terminal Board.....	0051
Load Terminal Board (MEP-501A and Mechron Sets)	0052
ON-OFF Load Circuit Breaker Assembly and Boot.....	0053
Flywheel Diode Assembly	0054
Diesel Engine Wiring Harness and Gasket, Control Panel.....	0055
Alternator Wiring Harness and Gasket, Control Panel	0056
Electrical Lead Wire(s) (Typical).....	0057
Load Terminal Board Cover (Lug Cover)	0058
Electromagnetic Interference (EMI) Filter (MEP-531A).....	0059
Low Oil Pressure (LOP) Switch.....	0060
Low Oil Pressure (LOP) Solenoid Assembly	0061
Low Oil Pressure (LOP) Engine Shutdown Cable.....	0062
Air Intake Heating Elements and Pipe.....	0063
Governor Regulator Bracket.....	0064
Cooling Fan Cover.....	0065
Recoil Starter Assembly	0066
Engine Oil Strainer	0067
Valve Cover	0068
Starter Assembly (MEP-501A)	0069
Engine Wiring Harness.....	0070
Alternator Wiring Harness (MEP-501A).....	0071
Preheater Lead.....	0072
Ground Stud Terminal	0073
Generator Control Unit	0074
Voltage Regulator Assembly	0075
Diesel Engine Wiring Harness, Control Panel.....	0076
Alternator Wiring Harness, Control Panel.....	0077
Engine/Alternator Assembly	0078
Diesel Engine	0079
Starter (MEP-531A).....	0080
Rocker Arms and Push Rods	0081
Cylinder Head Assembly	0082
Intake and Exhaust Valves.....	0083

<u>Title</u>	<u>WP Sequence No.</u>
Fuel Injection Pump.....	0084
Crankcase Cover.....	0085
Oil Pump Assembly	0086
Flywheel	0087
Dynamo	0088
AC Alternator Assembly (MEP-531A).....	0089
AC Alternator Bearing (MEP-531A).....	0090
DC Alternator Assembly (MEP-501A)	0091
DC Alternator Bearings (MEP-501A).....	0092
DC Alternator Diodes and Capacitors (MEP-501A).....	0093
Frame	0094
2 kW Deprocessing Checklist.....	0095
Dewey/Mechron Cross-Reference List.....	0096
Electrical Lead Fabrication for Control Panel	0097
Illustrated List of Manufactured Items Introduction.....	0098
Potentiometer, VOLTAGE ADJ. (P/N: 95-8077).....	0099
Potentiometer, VOLTAGE ADJ. (P/N: 95-8014).....	0100
Flywheel Diode Assembly (P/N: 95-8050).....	0101
Capacitor Assembly (P/N: 95-8017)	0102
LOP Solenoid Valve Assembly (P/N: 95-8019)	0103
Wiring Harness, Control Panel (P/N: 95-8084).....	0104
Wiring Harness, Control Panel (P/N: 95-8023).....	0105
Wiring Harness, Control Panel (P/N: 95-8075).....	0106
Wiring Harness, Control Panel (P/N: 95-8022).....	0107
Wiring Harness, Engine (P/N: 95-8029)	0108
LOP Shutdown Cable (P/N: 95-8082)	0109
Preheater Lead, Electrical (P/N: 95-8141).....	0110
Wiring Harness, Alternator (P/N: 95-8028).....	0111
Transient Suppressor (P/N: 95-8025).....	0112
Flywheel Locking Handle (P/N: 114250-92101).....	0113
Flywheel Extractor (P/N: 114250-92130)	0114
Torque Limits.....	0115

FIELD MAINTENANCE**2 kW MEP-501A/531A MILITARY TACTICAL GENERATOR SETS****SERVICE UPON RECEIPT****INITIAL SETUP:****Tools and Special Tools**

Tool Kit, General Mechanic's Automotive or Standard Automotive Tool Set (WP 0159, Table 2, Item 6)

Materials/Parts

As required

References

WP 0005, Operation Under Usual Conditions
 WP 0007, Operator Troubleshooting Index
 WP 0010, Table 1
 WP 0083, Intake and Exhaust Valves, Adjustment
 WP 0095, 2 kW Deprocessing Checklist
 WP 0162, Table 1

Equipment Condition

Generator set shut down (WP 0005, Stopping Procedure)
 Cable disconnected for NATO Slave Receptacle (WP 0005)

SITING**Site Selection**

1. Place the generator set on a level site if possible. Provide enough clearance around the generator set to allow for normal operation and maintenance functions.

WARNING

Exhaust discharge contains deadly gases. Do not operate generator set in enclosed area unless exhaust discharge is properly vented outside. Position as far away from personnel, shelters, and occupied vehicles as possible. Failure to observe this warning could result in severe personal injury or death due to carbon monoxide poisoning.

NOTE

Under normal operating conditions, generator set will vibrate "walk" on hard surfaces. Block generator set appropriately.

2. In a bivouac location, take measures to minimize noise and exhaust impacts on personnel. Place generator sets as far as possible from personnel areas.

END OF TASK**SERVICE UPON RECEIPT OF MATERIEL****Inspecting the Equipment**

Unpacking. The following should be performed on the generator set prior to use.

1. Remove all packaging material.
2. Inspect identification plate for positive identification of generator set.
3. Make a thorough inspection of generator set for any damage that may have occurred during shipment.
4. Inspect entire generator set carefully for loose and/or missing hardware.

END OF TASK

INSTALLATION INSTRUCTIONS

NOTE

The diesel engine must be broken-in, avoiding heavy loads (no greater than 75%), for a period of twenty (20) hours to ensure proper operation of the generator set. After the initial break-in period, engine lubricating oil must be changed, cylinder head nuts torque must be checked, and intake and exhaust valve clearances must be checked and adjusted. Refer to WP 0083, Adjustment.

1. The generator set is normally received either from the manufacturer or long term storage with the fuel system drained, however, the crankcase will be filled with oil.
2. In order to put the generator set into service, perform the following procedure:

CAUTION

When checking the diesel engine lube oil level, the generator set must be level. If it is tilted, an incorrect oil level may be indicated. Insert dipstick into the oil pan. Do not screw in the dipstick. Overfilling can cause overheating, increased oil pressure, and severe damage.

- a. Check oil level indicated on dipstick, see Figure 1. The proper viscosity of oil should be used for the following conditions: (Refer to WP 0162, Table 1, Items 14 and 15.)

-40 to 0 °F (-40 to -18 °C)	MIL-PRF-46167 0W30
0 to 120 °F (-18 to 49 °C)	MIL-PRF-2104 15W40

CAUTION

Use of fuel other than that for which the fuel injection timing is set, can damage the engine.

- b. Before starting engine, position fuel filter shutoff valve located on fuel filter to ↓O (open), and fill tank with appropriate diesel fuel. Ensure that fuel used is the grade of diesel fuel appropriate for the current fuel injection timing. If necessary, contact next higher level of maintenance to adjust fuel injection timing.
- c. Use of non-recommended fuel may cause clogging in fuel oil filter, fuel injection pump, or fuel injection nozzle. This clogging often causes sudden engine stops after starting. Diesel fuel oil substitutes are not recommended; they may be harmful to the fuel system components.
- d. Prime and bleed fuel system. Refer to WP 0005, Priming and Bleeding the Fuel System.
- e. Start engine. Refer to WP 0005, Manual Starting [23 °F (-5 °C) to 122 °F (50 °C)]. If engine will not start, refer to WP 0007, Operator Troubleshooting Index.

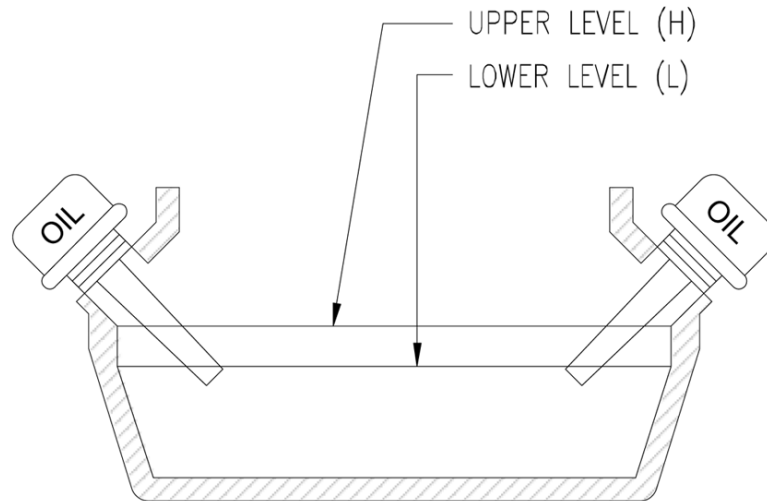

Figure 1. Oil Level.

END OF TASK

PRELIMINARY SERVICING OF EQUIPMENT

Perform the Preventive Maintenance Checks and Services; see WP 0010, Table 1 and WP 0095 for deprocessing instructions.

END OF TASK

END OF WORK PACKAGE

FIELD MAINTENANCE

2 kW MEP-501A/531A MILITARY TACTICAL GENERATOR SETS

FIELD PMCS INTRODUCTION

INITIAL SETUP:

Tools and Special Tools

Tool Kit, General Mechanic's Automotive or Standard Automotive Tool Set (WP 0159, Table 2, Item 6)
Multimeter (WP 0159, Table 2, Item 3)

Materials/Parts

Grounding Equipment
DA FORM 2404

Personnel Required

91D

References

WP 0004, Description and Use of Operator Controls and Indicators
WP 0012, Field Troubleshooting Index
WP 0016, Field PMCS Instructions

Equipment Condition

Generator set shut down (WP 0005, Stopping Procedure)
Cable disconnected for NATO Slave Receptacle (WP 0005)

INTRODUCTION TO FIELD PMCS TABLE

WP 0016, Table 1 (PMCS table) has been provided so you can keep your equipment in good operating condition and ready for its primary mission.

Preventive Maintenance Checks and Service (PMCS) are those scheduled procedures that are essential to the efficient operation of the equipment. PMCS prevent possible damage that might occur through neglect or failure to observe warning symptoms on time. Ensure all noted discrepancies are corrected.

WARNING

Remove metal jewelry when working on electrical system/components. Failure to observe this warning could cause severe personnel injury from electric shock.

Warnings and Cautions

Always observe the **WARNINGS**, **CAUTIONS**, and **NOTES** appearing in your PMCS table. Warnings and cautions appear before applicable procedures. You must observe these **WARNINGS** to prevent serious injury to yourself and others. You must observe **CAUTIONS** to prevent your equipment from being damaged. You must observe **NOTES** to ensure procedures are performed properly.

FIELD PMCS

WP 0016, Table 1 lists all scheduled maintenance tasks required for the generator set components and accessories. The columns of the PMCS table are described below.

Explanation of Table Entries

Item No. Column. Numbers in this column are for reference. When completing DA Form 2404 (Equipment Inspection and Maintenance Worksheet), include the item number for the check/service indicating a fault. Item numbers also appear in the order that you must do checks and services for the intervals listed.

Interval Column. This column tells you when you must do the procedure in the procedure column. Perform procedures such as "Monthly" or "Quarterly" at the listed calendar interval. Perform procedures designated by number of hours when the equipment has been operated for that many hours.

Item to be Checked or Serviced Column. This column lists the item to be checked or serviced.

Procedure Column. This column gives the procedures for checking or servicing the item listed in the item to be checked or serviced column. You must perform the procedure to know if the generator set is ready or available for its intended mission or operation. You must do the procedure at the time stated in the interval column.

Equipment Not Ready/Available if: Column. Information in this column tells you what faults will keep the generator set from being capable of performing its primary mission. If checks or services show faults listed in this column, do not return the generator set to service until the faults have been corrected.

NOTE

The terms ready/available and mission capable refer to the same status: generator set is on hand and is able to perform its combat missions (see DA Pam 750-8).

Other Table Entries

Be sure to observe all special information and notes that appear in your table.

Reporting and Correcting Deficiencies

If your generator set does not perform as required, refer to troubleshooting for possible problem. Any malfunctions, failures, or discrepancies shall be recorded on DA Form 2404 or DA Form 5988E and reported to higher-level maintenance, refer to DA PAM 750-8.

PREVENTIVE MAINTENANCE PROCEDURES

NOTE

Within designated intervals, these checks are to be performed in the order listed. If the generator set must be kept in continuous operation, check and service only those items that can be accessed without interrupting operations. Complete checks and services when the generator set is shut down.

Monthly

Perform "Monthly" PMCS in WP 0016, Table 1. Observe WARNINGS and CAUTIONS contained in this manual and on plates installed on equipment.

Quarterly

Perform "Quarterly" PMCS in WP 0016, Table 1. Observe WARNINGS and CAUTIONS contained in this manual and on plates installed on equipment.

Semi-annually

Perform "Semi-annually" PMCS in WP 0016, Table 1. Observe WARNINGS and CAUTIONS contained in this manual and on plates installed on equipment.

Bi-annually

Perform "Bi-annually" PMCS in WP 0016, Table 1. Observe WARNINGS and CAUTIONS contained in this manual and on plates installed on equipment.

Hourly

Perform "Hourly" PMCS in WP 0016, Table 1. Observe WARNINGS and CAUTIONS contained in this manual and on plates installed on equipment.

Order in Which PMCS Will be Done

Always perform preventive maintenance in the same order.

Routine Inspections

Use the following information to help identify potential problems before and during checks and services.

WARNING

Remove metal jewelry when working on electrical system/components. Failure to observe this warning could cause severe personnel injury from electric shock.

WARNING

High voltage is produced when this generator set is in operation. Use care when working around an open control panel with the generator set operating. Improper operation and/or failure to follow this warning could result in personal injury or death by electrocution.

WARNING

Cleaning solvents are flammable and toxic to eyes, skin, and respiratory tract. Skin/eye protection required. Avoid repeated/prolonged contact. Good general ventilation is normally adequate.

1. Keep it clean. Dirt, grease, and oil get in the way and may cover up a serious problem. Use dry cleaning solvent to clean metal surfaces.
2. Use soap and water to clean rubber or plastic parts and material.
3. Check all bolts, nuts, and screws to make sure they are not loose, missing, bent, or broken. DO not try to check them all with a tool, but look for chipped paint, bare metal, or rust around bolt heads. If you find one loose, tighten it or report it to field level maintenance.
4. Inspect welds. Look for loose or chipped paint, rust, or gaps where parts are welded together. If a broken weld is found, report it to field level maintenance.
5. Inspect electrical wires, connectors, terminals, and receptacles. Look for cracked or broken insulation, bare wires, and loose or broken connectors. Tighten loose connectors and make sure wires are in good condition. Examine terminals and receptacles for serviceability. If deficiencies are found, report them to field level maintenance.
6. Inspect hoses and fluid lines. Look for wear, damage, and leaks. Make sure that clamps and fittings are tight. Wet spots and stains around a fitting or connector can mean a leak. If a leak comes from a loose connector, or if something is broken or worn out, report it to field level maintenance.

CORROSION PREVENTION AND CONTROL (CPC)

Corrosion Prevention and Control (CPC) of Army materiel is a continuing concern. It is important that any corrosion problems with this item be reported so that the problem can be corrected and improvements can be made to prevent the problem in future items. Corrosion specifically occurs with metals. It is an electrochemical process that causes the degradation of metals. It is commonly caused by exposure to moisture, acids, bases, or salts. An example is the rusting of iron. Corrosion damage in metals can be seen, depending on the metal, as tarnishing, pitting, fogging, surface residue, and/or cracking. Plastics, composites, and rubbers can also degrade. Degradation is caused by thermal (heat), oxidation (oxygen), solvation (solvents), or photolytic (light, typically UV) processes. The most common exposures are excessive heat or light. Damage from these processes will appear as cracking, softening, swelling, and/or breaking. SF Form 368, Product Quality Deficiency Report should be submitted to the address specified in DA PAM 750-8, The Army Maintenance Management System (TAMMS) Users Manual.

FLUID LEAKAGE

It is necessary for you to know how fluid leakage affects the status of the 2 kW Generator Set. Following are types/classes of leakage you need to know to be able to determine the status of the 2 kW Generator Set. Learn these leakage definitions and remember - when in doubt, notify your supervisor. Equipment operation is allowed with minor leakage (Class I or II). Consideration must be given to fluid capacity in the item/system being checked/inspected. When in doubt, notify your supervisor.

When operating with Class I or II leaks, continue to check fluid levels as required in the PMCS.

Class III leaks should be reported immediately to your supervisor.

Table 1. Leakage Definitions.

Leakage Class	Leakage Definition
Class I	Seepage of fluid (as indicated by wetness or discoloration) not great enough to form drops.
Class II	Leakage of fluid great enough to form drops, but not enough to cause drops to drip from the item being checked/inspected.
Class III	Leakage of fluid (other than fuel) greater than three drops per minute that fall from the item being checked/inspected.

CAUTION

Equipment operation is allowable with minor leakages (Class I or II). Of course, consider the fluid capacity of the item/system being checked/inspected. When in doubt, notify maintenance.

While operating with Class I or Class II leaks, continue to check fluid levels as required in your PMCS. All leaks should be reported to maintenance.

END OF WORK PACKAGE

FIELD MAINTENANCE

**2 kW MEP-501A/531A MILITARY TACTICAL GENERATOR SETS
FIELD PMCS, INCLUDING LUBRICATION INSTRUCTIONS**

INITIAL SETUP:**Tools and Special Tools**

Tool Kit, General Mechanic's Automotive or
Standard Automotive Tool Set
(WP 0159, Table 2, Item 6)
Multimeter (WP 0159, Table 2, Item 3)

Materials/Parts

Grounding Equipment
Cloth, Cleaning (WP 0162, Table 1, Item 4)
Oil, Lubricating (WP 0162, Table 1, Item 14)
Oil, Lubricating (WP 0162, Table 1, Item 15)

References

WP 0004, Description and Use of Operator Controls
and Indicators
WP 0012, Field Troubleshooting Index
MIL-PRF-46167 0W30
MIL-PRF-2104-15W40
WP 0017, Fuel Filter Element Replacement
WP 0018, Air Filter Element Replacement
WP 0020, Alternator Brushes Inspection
(MEP-531A)
WP 0021, Alternator Flexible Coupling Inspection
(MEP-501A)
WP 0022, Engine resilient Mounts Replacement
WP 0025, Cylinder Head Nuts Tightening
WP 0031, Exhaust System Components
WP 0062, Low Oil Pressure (LOP) Engine Shutdown
Cable
WP 0067, Engine Oil Strainer
WP 0083, Intake and Exhaust Valves

Equipment Condition

Generator set shut down (WP 0005, Stopping
Procedure)
Cable disconnected for NATO Slave Receptacle
(WP 0005)

FIELD LUBRICATION INSTRUCTIONS

Lubrication not required by field support.

NOTE

Within designated intervals, these checks are to be performed in the order listed.

Table 1. Field Preventive Maintenance Checks and Services for MEP-501A/MEP-531A.

ITEM NO.	INTERVAL	ITEM TO BE CHECKED OR SERVICED	PROCEDURE	EQUIPMENT NOT READY/AVAILABLE IF:
1	MONTHLY	Diesel Engine	Check for loose, damaged, or missing parts. Tighten loose parts. Repair or replace damaged or missing parts. Inspect decompression lever "A" for debris. Clean if needed.	Engine parts are loose, damaged, or missing.

Table 1. Field Preventive Maintenance Checks and Services for MEP-501A/MEP-531A. - Continued

ITEM NO.	INTERVAL	ITEM TO BE CHECKED OR SERVICED	PROCEDURE	EQUIPMENT NOT READY/AVAILABLE IF:
2	50 HOURS	Primary and Prefilter Air Filter Elements	Inspect for clogged primary (paper) air filter element. Clean every 50 hours or as required, or replace element if damaged. Replace pre-filter (foam) element. Refer to WP 0018, Air Filter Element Replacement.	Air cleaner element is clogged or damaged.
3	MONTHLY	Ground Terminal Lug	Check for damage or corrosion.	
4	MONTHLY	Control Panel	Check for damaged/missing edge protector on load terminal board cover. NOTE There is no edge protector on side with latching screws.	
5	20 HOURS (1ST TIME) THEN EVERY 100 HOURS	Engine Lube System	Change diesel engine oil after the first 20 hours of operation and then after every 100 hours. 1. Remove diesel engine oil drain plug and collect oil in an appropriate chemical resistant container for disposition/disposal through the local servicing Defense Revitalization and Marketing Office. 2. Remove, clean, and install oil strainer, refer to WP 0067, Engine Oil Strainer. 3. Add proper lube oil for the following operating environments: -40 to 0 °F MIL-PRF-46167 (-40 to -18 °C) 0W30/0 to 120 °F MIL-PRF-2104 (-18 to 49 °C) 15W40	
6	100 HOURS	Fuel Filter Element	Replace fuel filter element. Inspect gaskets for damage. Refer to WP 0017, Fuel Filter Element Replacement.	
7	50 HOURS	Spark Arrestor	Check for damaged, missing or corroded spark arrestor. Clean spark arrestor, refer to WP 0031, Exhaust System Components. Check per (F) TO 38-1-23.	
8	1,000 HOURS	AC Alternator Brushes, Caps, Wires, and Holders (MEP-531A)	Check for worn alternator brushes. Length must be a minimum of 0.5 in. (1.3 cm). Check for damaged or missing brush caps, wires, and holders. Refer to WP 0020, Alternator Brushes Inspection (MEP-531A).	Alternator brushes worn. Damaged or missing brush caps, wires, and holders.

Table 1. Field Preventive Maintenance Checks and Services for MEP-501A/MEP-531A. - Continued

ITEM NO.	INTERVAL	ITEM TO BE CHECKED OR SERVICED	PROCEDURE	EQUIPMENT NOT READY/AVAILABLE IF:
9	20 HOURS (1ST TIME) THEN EVERY 500 HOURS	Intake and Exhaust Valves	Adjust valve head clearance after the first 20 hours of operation and then every 500 hours. Refer to WP 0083, Adjustment.	
10	500 HOURS	Primary and Prefilter Air Filter Elements	Replace air filter elements. Refer to WP 0018, Air Filter Element Replacement.	
11	20 HOURS (1ST TIME) THEN EVERY 500 HOURS	Cylinder Head Nuts	Check after first 20 hours of operation and then every 500 hours. Check for loose head nuts. Torque cylinder head nuts. Refer to WP 0025, Cylinder Head Nuts Tightening.	Head nuts are loose.
12	1,000 HOURS	Fuel Injector	Replace every 1,000 hours. Refer to WP 0019, Fuel Injector Replacement.	
13	1,500 HOURS	DC Alternator Brush Holder	Contact next higher level of maintenance to replace brush holder assembly.	
14	2,000 HOURS	Fuel Injection Pump	Contact next higher level of maintenance to replace fuel injection pump.	
15	SEMI-ANNUALLY	Generator Set, Engine/Alternator, and Control Panel	Check for damage, corrosion, missing, or loose attaching hardware.	Damaged, corroded, missing, or loose hardware.
16	SEMI-ANNUALLY	Fuel Lines	Inspect for breaks and/or damage. Replace damaged fuel lines.	Fuel lines leak or show signs of wear or damage.
17	SEMI-ANNUALLY	Fuel Tank	Check for damaged, corroded, or missing fuel fill strainer, tank cap lug, and retaining rope.	Damaged, corroded, or missing components.
18	SEMI-ANNUALLY	Alternator (MEP-501A)	Check for damaged flexible sleeve coupling and flexible flange couplings. Refer to WP 0021, Alternator Flexible Coupling Inspection (MEP-501A).	Damaged alternator coupling components.
19	SEMI-ANNUALLY	Control Panel (External)	Check for damaged, corroded, or missing convenience receptacle and cover (MEP-531A); LOP engine shutdown cable grommet and cable guide; and slave receptacle.	Damaged, corroded, or missing control panel components.
20	SEMI-ANNUALLY	Control Panel (Internal)	Check for damaged terminal board jumper (MEP-531A) and ground straps, and damaged or burned wires and insulation on all electrical leads and harnesses. Ensure that protective cover on rear of instrument panel is secure.	Damaged control panel components.
21	SEMI-ANNUALLY	Load Terminal Board (MEP-501A and Mechtron Sets) Electromagnetic Interference (EMI) Filter (MEP-531A)	Check for damaged or corroded load terminals, load terminal board, and EMI filter load terminals. Check for damaged or missing retaining clips.	Damaged or corroded load terminals, terminal board, or EMI filter load terminals. Damaged or missing retaining clips.

Table 1. Field Preventive Maintenance Checks and Services for MEP-501A/MEP-531A. - Continued

ITEM NO.	INTERVAL	ITEM TO BE CHECKED OR SERVICED	PROCEDURE	EQUIPMENT NOT READY/AVAILABLE IF:
22	SEMI-ANNUALLY	Generator Set	Check ground strap for damage.	Damaged ground strap.
23	SEMI-ANNUALLY	Low Oil Pressure (LOP) Engine Shutdown Cable	Check for damaged push-pull cable and tube. Check cable adjustment. Refer to WP 0062, Low Oil Pressure (LOP) Engine Shutdown Cable.	Damaged or misadjusted LOP engine shutdown cable.
24	SEMI-ANNUALLY	Air Preheater Lead	Check for damaged or missing tubing and protective boot; damaged or burned wires and insulation.	Damaged air preheater lead.
25	SEMI-ANNUALLY	Engine Wiring Harness	Check for damaged, missing, corroded clamps; damaged or missing tubing and protective boot; and burned insulation.	Damaged, missing, or corroded engine wiring harness components.
26	SEMI-ANNUALLY	Alternator Wiring Harnesses	Check for damaged, missing, corroded clamps; damaged or missing tubing and protective boot; and burned insulation.	Damaged, missing, or corroded generator wiring harness components.
27	2,000 HOURS	Resilient Mounts	Replace resilient mounts after 2,000 hours. Refer to WP 0022, Engine Resilient Mounts Replacement.	
28	ANNUALLY	Frame	Check for damage and corrosion.	Damaged or corroded frame.
29	ANNUALLY	Fuel System	Check for damaged or corroded fuel tank brackets and guard.	Damaged or corroded components.
30	ANNUALLY	Engine/Alternator	Check for damaged, corroded alternator guard, brackets, engine mounting bracket, and fuel filter stiffener.	Damaged or corroded components.
31	ANNUALLY	Air Intake System	Check for damaged or corroded air filter plate and air filter cover.	Damaged or corroded air intake components.
32	ANNUALLY	Exhaust System	Check for damaged or corroded muffler and shroud; damaged or missing grommet; damaged muffler blanket; damaged, missing, or corroded retaining wire.	Damaged or corroded exhaust system components.
33	ANNUALLY	Alternator (MEP-531A and Mechron Sets)	Check for damaged engine adapter and damaged or corroded support bracket.	Damaged or corroded alternator components.
34	ANNUALLY	Control Panel	Check for damaged or missing panel mounts; panel housing; covers and hinges.	Damaged or missing control panel components.

MANDATORY REPLACEMENT PARTS LIST

There are no replacement parts required for these PMCS procedures.

END OF WORK PACKAGE

FIELD MAINTENANCE**2 kW MEP-501A/531A MILITARY TACTICAL GENERATOR SETS
FUEL FILTER ELEMENT REPLACEMENT: REMOVAL, INSTALLATION**

INITIAL SETUP:**Tools and Special Tools**

Tool Kit, General Mechanic's Automotive or Standard Automotive Tool Set (WP 0159, Table 2, Item 6)

Materials/Parts

Cloth, Cleaning (WP 0162, Table 1, Item 4)

References

WP 0005, Operation Under Usual Conditions

Equipment Condition

Generator set shut down (WP 0005, Stopping Procedure)
Cable disconnected for NATO Slave Receptacle (WP 0005)

WARNING

The fuels in this generator set are flammable. Do not smoke or use open flames when performing maintenance. Do not service or drain the fuel system while open flames are present. Flames and explosion could result in severe personal injury or death. Use a container or cloth to catch any excess fuel to prevent spilling over engine components. Be sure to properly dispose of diesel fuel and diesel fuel soaked cloths.

REMOVAL**NOTE**

For generator sets with the original Mechron configuration fuel filter assembly, use the replacement element, bowl, and O-ring listed in this manual.

1. Shut down generator set.

WARNING

The fuels in this generator set are flammable. Do not smoke or use open flames when performing maintenance. Do not service or drain the fuel system while open flames are present. Flames and explosion could result in severe personal injury or death. Use a container or cloth to catch any excess fuel to prevent spilling over engine components. Be sure to properly dispose of diesel fuel and diesel fuel soaked cloths.

2. Close fuel shutoff valve.
3. Unscrew retaining ring (Figure 1) and separate bowl and head using care not to spill diesel fuel trapped in bowl. Then pour diesel fuel into suitable container.
4. Remove and discard fuel filter element and gasket.

END OF TASK**INSTALLATION**

1. Clean bowl with clean cloth (WP 0162, Table 1, Item 4).
2. Install new fuel filter element in bowl.
3. Lubricate new gasket with clean diesel fuel and seat in land of bowl.
4. Assemble bowl to head and hand-tighten retaining ring.

5. Prime and bleed the fuel system. Refer to WP 0005, Priming and Bleeding the Fuel System, Steps 1 through 3 only.

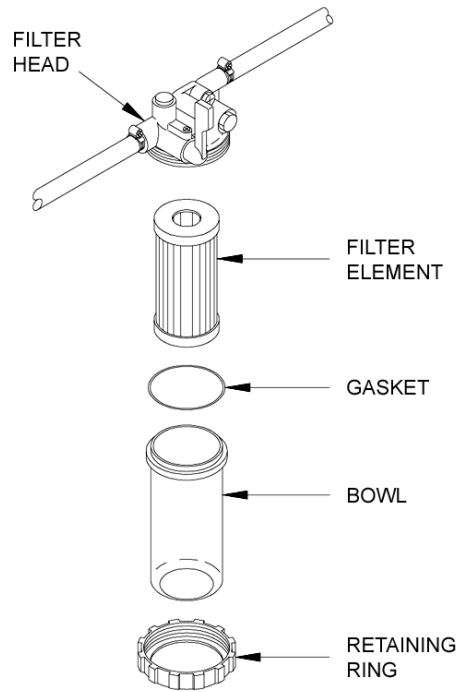

Figure 1. Fuel Filter Element Replacement.

END OF TASK

END OF WORK PACKAGE

FIELD MAINTENANCE**2 kW MEP-501A/531A MILITARY TACTICAL GENERATOR SETS****AIR FILTER ELEMENT REPLACEMENT: REMOVAL, CLEANING, INSTALLATION**

INITIAL SETUP:**Tools and Special Tools**

Tool Kit, General Mechanic's Automotive or Standard Automotive Tool Set (WP 0159, Table 2, Item 6)
Shop Equipment, Automotive Maintenance and Repair, Field Maintenance, Suppl 1 W/O Power (WP 0159, Table 2, Item 4)

References

WP 0162, Table 1, Item 15

Materials/Parts

Filter Element, Air (WP 0162, Table 1, Item 5)
Engine Oil (WP 0162, Table 1, Item 14)

Equipment Condition

Generator set shut down (WP 0005, Stopping Procedure)
Cable disconnected for NATO Slave Receptacle (WP 0005)

REMOVAL

1. Shut down generator set.
2. Remove wing nut (Figure 1), cover, and filter element with pre-filter.
3. Remove pre-filter from filter element.
4. If necessary, remove gaskets from mounting plate and cover. Clean adhesive residue from surfaces.

END OF TASK**CLEANING**

1. Inspect cover for cleanliness, cracks and other damage. Clean cover with mild soap and water.
2. Inspect filter element for cleanliness, dents, and crushed corrugations.
3. Replace damaged parts.
4. Replace filter element if dirty.
5. Replace pre-filter.

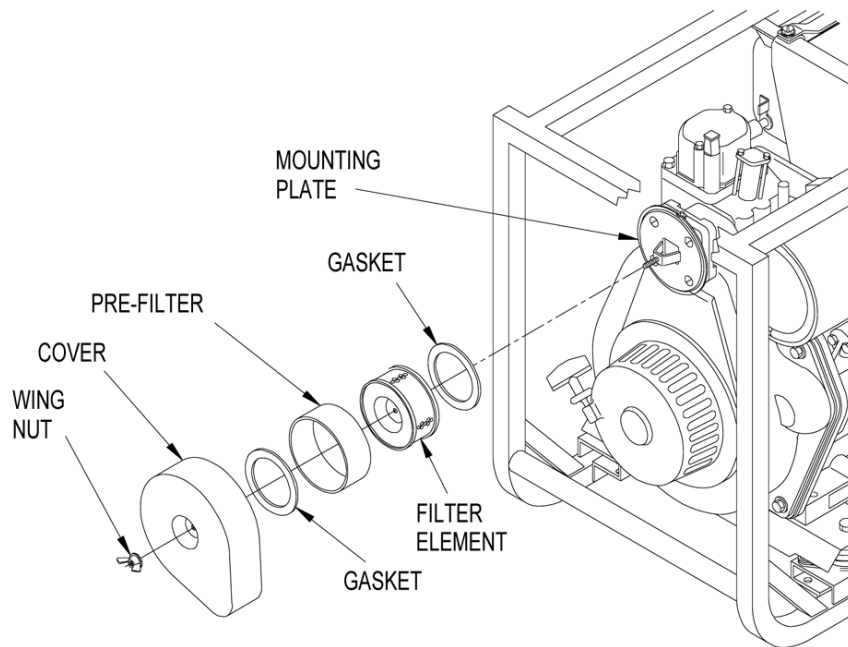

Figure 1. Air Filter Elements.

END OF TASK

INSTALLATION

1. If removed, install new gaskets (Figure 1) on mounting plate and cover.
2. Soak new pre-filter in clean engine oil (WP 0162, Table 1, Item 15) and squeeze out ALL excess oil.
3. Install pre-filter over filter element. Pre-filter should fit snugly over filter element.
4. Position filter element with pre-filter and cover on mounting plate.
5. Install wing nut.

END OF TASK

END OF WORK PACKAGE

FIELD MAINTENANCE**2 kW MEP-501A/531A MILITARY TACTICAL GENERATOR SETS****FUEL INJECTOR REPLACEMENT: REMOVAL, INSPECTION, INSTALLATION**

INITIAL SETUP:**Tools and Special Tools**

Tool Kit, General Mechanic's Automotive or Standard Automotive Tool Set (WP 0159, Table 2, Item 6)

Materials/Parts

Wire, 0.019 in. diameter (WP 0162, Table 1, Item 22)

References

WP 0005, Operation Under Usual Condition
WP 0162, Table 1, Item 22

Equipment Condition

Generator set shut down (WP 0005, Stopping Procedure)
Cable disconnected for NATO Slave Receptacle (WP 0005)

WARNING

The fuels in this generator set are flammable. Do not smoke or use open flames when performing maintenance. Do not service or drain the fuel system while open flames are present. Flames and explosion could result in severe personal injury or death. Use a container or cloth to catch any excess fuel to prevent spilling over engine components. Be sure to properly dispose of diesel fuel and diesel fuel soaked cloths.

REMOVAL

1. Shut down generator set.
2. Disconnect pressure and return fuel lines from fuel injector (Figure 1).
3. Remove nuts and retainer from cylinder head.

CAUTION

To prevent damage to nozzle tip, wrap fuel injector in a clean cloth after removal. Do not place unprotected nozzle tip directly on dirty surface.

4. Pull fuel injector straight out of cylinder head, wrap in clean cloth, and remove spacer and gasket. If gasket (black plastic) remains in cylinder head, use a bolt (5/16 in. diameter) that will thread into gasket to remove.

END OF TASK**INSPECTION**

1. Inspect injector for nicks, cracks, scoring, corrosion, and other damage.
2. Inspect nozzle tip for carbon deposits. Carefully clean deposits from nozzle body and clean nozzle injection ports with 0.019 in. diameter wire (WP 0162, Table 1, Item 22).

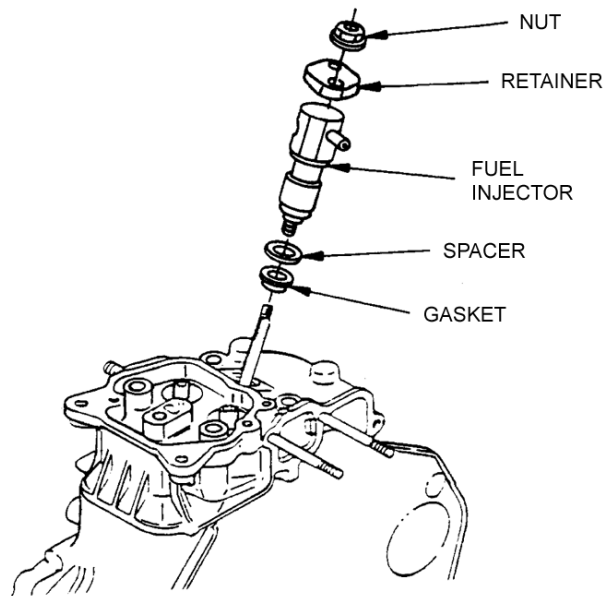

Figure 1. Fuel Injector Replacement.

END OF TASK

INSTALLATION

1. Clean fuel injector sleeve surface in cylinder head.
2. Install new gasket (Figure 1), spacer, and fuel injector in cylinder head.

NOTE

Ensure fuel injector is positioned to connect pressure fuel line prior to securing in cylinder head.

3. Secure fuel injector in cylinder head with retainer and nuts. Torque nuts evenly to 7-9 ft•lb (9-12 N•m).
4. Connect pressure and return fuel lines. Bleed fuel system if necessary. Refer to WP 0005, Priming and Bleeding the Fuel System.

END OF TASK

END OF WORK PACKAGE

FIELD MAINTENANCE

2 kW MEP-501A/531A MILITARY TACTICAL GENERATOR SETS

ALTERNATOR BRUSHES INSPECTION (MEP-531A): REMOVAL, INSPECTION, INSTALLATION

INITIAL SETUP:

Tools and Special Tools

Tool Kit, General Mechanic's Automotive or Standard Automotive Tool Set (WP 0159, Table 2, Item 6)
Shop Equipment, Automotive Maintenance and Repair, Field Maintenance, Suppl 1 W/O Power (WP 0159, Table 2, Item 4)

Materials/Parts

As required

Equipment Condition

Generator set shut down (WP 0005, Stopping Procedure)
Cable disconnected for NATO Slave Receptacle (WP 0005)
Control Panel Assembly removed (WP 0032)

REMOVAL

1. Shut down generator set.
2. Remove control panel assembly, refer to WP 0032, Removal.
3. Remove capscrews (Figure 1), lockwashers, and guard from alternator.

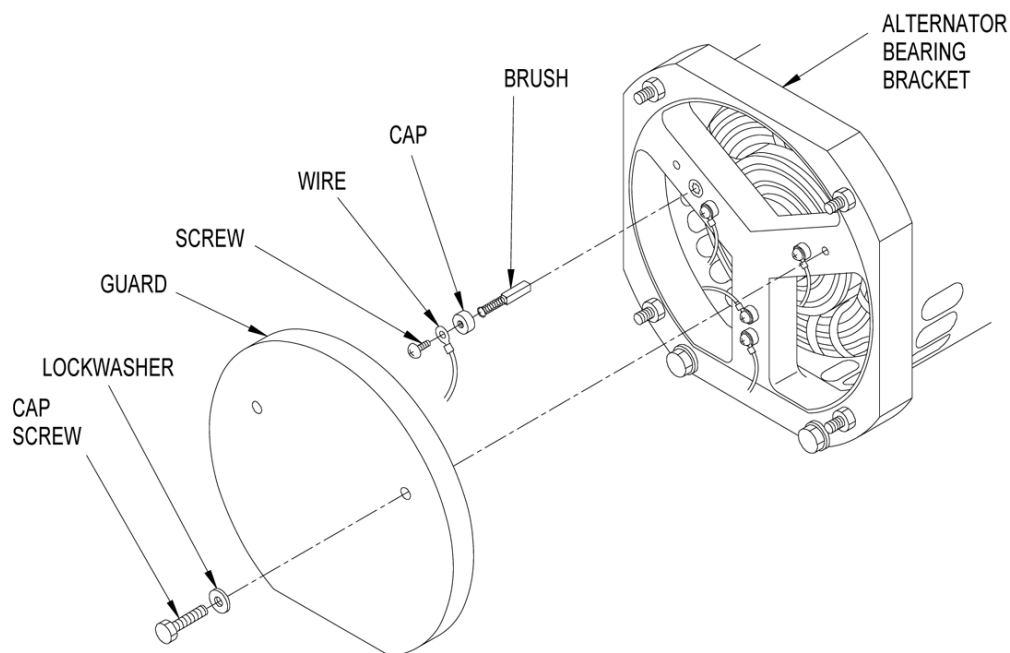

Figure 1. AC Alternator Brushes.

4. Tag stator wires and brush wires connected by screws.
5. Remove screws and brush wires, and disconnect stator wires from bearing bracket.

6. Unscrew brush caps and lift brushes out gently.

END OF TASK**INSPECTION**

1. Inspect brush wires for security of terminals, cracked insulation, and other damage.
2. Inspect brush caps for cracks and stripped threads.
3. Measure brush length [0.875-0.50 in. (2.2-1.3 cm)].
4. Replace damaged or worn parts.

END OF TASK**INSTALLATION**

1. Insert brushes in bearing bracket and secure with brush caps.
2. Connect stator wires and brush wires with screws. Remove tags.
3. Install guard on alternator with lockwashers and capscrews. Cross tighten capscrews to 6 ft•lb (8.2 N•m).
4. Install control panel assembly, refer to WP 0032, Installation.

END OF TASK**END OF WORK PACKAGE**

FIELD MAINTENANCE**2 kW MEP-501A/531A MILITARY TACTICAL GENERATOR SETS****ALTERNATOR FLEXIBLE COUPLING INSPECTION (MEP-501A): REMOVAL, INSPECTION, INSTALLATION**

INITIAL SETUP:**Tools and Special Tools**

Tool Kit, General Mechanic's Automotive or Standard Automotive Tool Set (WP 0159, Table 2, Item 6)
Shop Equipment, Automotive Maintenance and Repair, Field Maintenance, Suppl 1 W/O Power (WP 0159, Table 2, Item 4)

Materials/Parts

As required

Equipment Condition

Generator set shut down (WP 0005, Stopping Procedure)
Cable disconnected for NATO Slave Receptacle (WP 0005)
Control Panel Assembly removed (WP 0032)

REMOVAL

1. Shut down generator set.
2. Remove control panel assembly, refer to WP 0032, Removal.
3. Remove capscrews (Figure 1), lockwashers, washers, and guard from engine adapter.
4. Support rear of alternator. Then remove self-locking nuts, washers, capscrews, and ground strap, securing alternator to engine adapter. Carefully remove alternator and sleeve coupling.

END OF TASK**INSPECTION**

1. Inspect sleeve coupling for damage and wear. Replace sleeve coupling if damaged or worn.
2. Inspect flexible flange couplings on alternator and engine crankshaft for damage and wear. If damaged or worn, refer to next higher level of maintenance.

END OF TASK**INSTALLATION**

1. Position and support alternator (Figure 1) with sleeve coupling to engine adapter. Ensure that external teeth on sleeve coupling engage the internal teeth of alternator and engine crankshaft flexible flange couplings.
2. Secure alternator to engine adapter with capscrews, washers, and new self-locking nuts ensuring that ground strap is secured under capscrew head on right side. Torque self-locking nuts to 18 ft•lb (24.4 N•m).
3. Install guard with capscrews, lockwashers, and washers.
4. Install control panel assembly, refer to WP 0032, Installation.

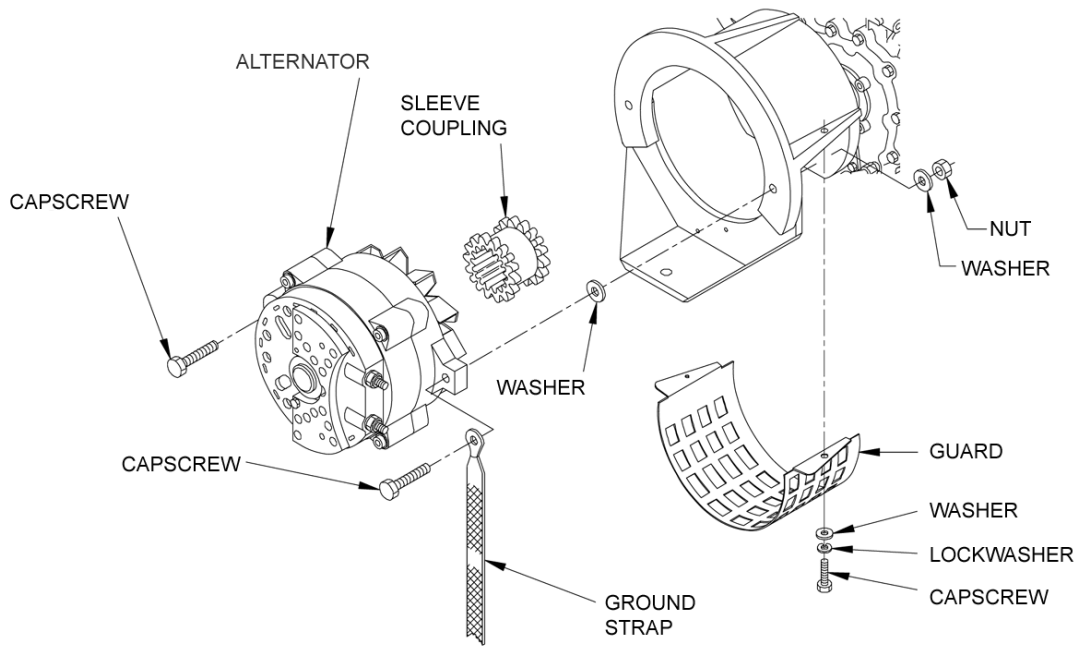

Figure 1. Alternator Flexible Coupling (MEP-501A).

END OF TASK

END OF WORK PACKAGE

FIELD MAINTENANCE**2 kW MEP-501A/531A MILITARY TACTICAL GENERATOR SETS
ENGINE RESILIENT MOUNTS REPLACEMENT: REMOVAL, INSTALLATION**

INITIAL SETUP:**Tools and Special Tools**

Tool Kit, General Mechanic's Automotive or Standard Automotive Tool Set (WP 0159, Table 2, Item 6)
Shop Equipment, Automotive Maintenance and Repair, Field Maintenance, Suppl 1 W/O Power (WP 0159, Table 2, Item 4)

Materials/Parts

As required

References

WP 0023, Figure 1

Equipment Condition

Generator set shut down (WP 0005, Stopping Procedure)
Cable disconnected for NATO Slave Receptacle (WP 0005)

REMOVAL

1. Shut down generator set.
2. Remove capscrews (WP 0023, Figure 1), lockwashers, and washers securing resilient mounts to engine support bracket.
3. Remove capscrew, lockwasher, and washer securing ground strap to side of engine crankcase.

CAUTION

Use caution not to lift engine so high that fuel line from fuel tank to fuel filter stretches and breaks.

4. Lift engine, with support bracket, approximately 1-1 inches and insert block under engine to hold in position.
5. Remove nuts, lockwashers, washers, ground strap, and capscrews with washers securing resilient mounts to generator set frame. Then remove and discard resilient mounts.

END OF TASK**INSTALLATION**

1. Position new resilient mounts on generator set frame and secure with capscrews, washers, lockwashers, and nuts ensuring engine ground strap is installed under left rear nut and washers. Torque nuts to 17 ft•lb (23 N•m).
2. Remove block and lower engine while aligning holes in engine support bracket with resilient mounts.
3. Secure engine support bracket to resilient mounts with capscrews, washers, and lockwashers. Torque capscrews to 17 ft•lb (23 N•m).
4. Secure ground strap on side of engine crankcase with capscrew, lockwasher, and washer.

END OF TASK**END OF WORK PACKAGE**

FIELD MAINTENANCE**2 kW MEP-501A/531A MILITARY TACTICAL GENERATOR SETS****ALTERNATOR RESILIENT MOUNT REPLACEMENT (MEP-531A): REMOVAL, INSTALLATION**

INITIAL SETUP:**Tools and Special Tools**

Tool Kit, General Mechanic's Automotive or Standard Automotive Tool Set (WP 0159, Table 2, Item 6)
Shop Equipment, Automotive Maintenance and Repair, Field Maintenance, Suppl 1 W/O Power (WP 0159, Table 2, Item 4)

Materials/Parts

As required

Equipment Condition

Generator set shut down (WP 0005, Stopping Procedure)
Cable disconnected for NATO Slave Receptacle (WP 0005)

REMOVAL

1. Shut down generator set.
2. Remove nuts (Figure 1), lockwashers, capscrews with washers, and ground strap securing alternator-to-alternator bracket.

CAUTION

Use caution not to lift alternator so high that fuel line from fuel tank to fuel filter stretches and breaks, or alternator wiring harness is damaged.

3. Lift alternator approximately 1-1 inches and insert block under alternator to hold in position.
4. Remove nuts, lockwashers, washers and capscrews securing diesel engine resilient mount and ground strap to generator set frame. Then, remove and discard resilient mount.
5. Remove capscrew, washer, and lockwasher securing resilient mount to alternator bracket. Then remove and discard resilient mount.

END OF TASK**INSTALLATION**

1. Install new resilient mount on alternator bracket with capscrew, washer, and lockwasher. Torque capscrew to 17 ft•lb (23 N•m).
2. Install new resilient mount and ground strap with alternator bracket on generator set frame with capscrews, washers, lockwashers, and nuts. Torque nuts to 17 ft•lb (23 N•m).
3. Remove block and lower alternator onto alternator bracket. Secure alternator to alternator bracket with capscrews, washers, lockwashers, and nuts ensuring alternator ground strap is installed under head of right capscrew and washers.

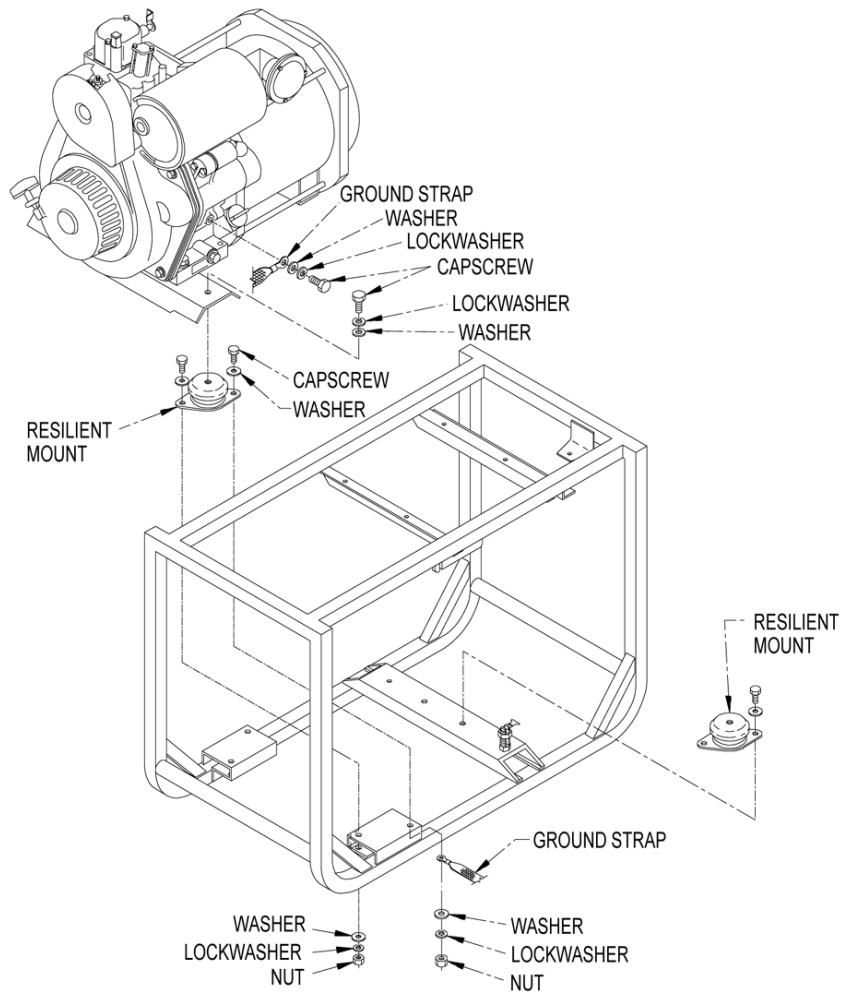

Figure 1. Resilient Mounts.

END OF TASK

END OF WORK PACKAGE

FIELD MAINTENANCE**2 kW MEP-501A/531A MILITARY TACTICAL GENERATOR SETS****ALTERNATOR RESILIENT MOUNT REPLACEMENT (MEP-501A): REMOVAL, INSTALLATION**

INITIAL SETUP:**Tools and Special Tools**

Tool Kit, General Mechanic's Automotive or Standard Automotive Tool Set (WP 0159, Table 2, Item 6)
Shop Equipment, Automotive Maintenance and Repair, Field Maintenance, Suppl 1 W/O Power (WP 0159, Table 2, Item 4)

Materials/Parts

As required

Equipment Condition

Generator set shut down (WP 0005, Stopping Procedure)
Cable disconnected for NATO Slave Receptacle (WP 0005)

REMOVAL

1. Shut down generator set.
2. Remove capscrew (Figure 1), washer, and lockwasher securing alternator support bracket to resilient mount.

CAUTION

Use caution not to lift alternator so high that fuel line from fuel tank to fuel filter stretches and breaks, or alternator wiring harness is damaged.

3. Lift alternator approximately 1-1 inches and insert block under alternator to hold in position.
4. Remove nuts, lockwashers, washers and capscrews securing diesel engine resilient mount to generator set frame. Then remove and discard resilient mount.

END OF TASK**INSTALLATION**

1. Install new resilient mount on generator set frame with capscrews, washers, lockwashers, and nuts. Torque nuts to 17 ft•lb (23 N•m).
2. Remove block and lower alternator while aligning holes in alternator support bracket with resilient mount.
3. Secure alternator support bracket to resilient mount with capscrew, washer, and lockwasher. Torque capscrew to 17 ft•lb (23 N•m).

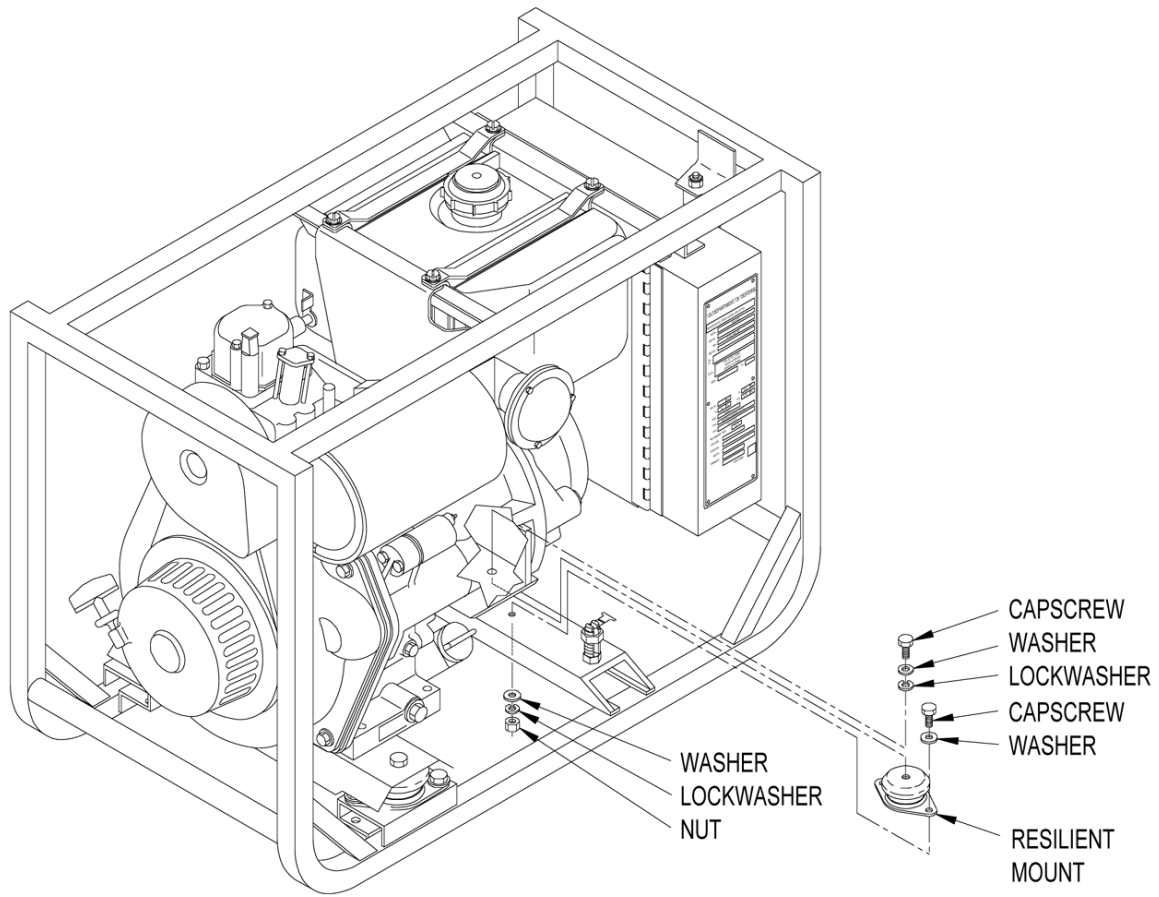

Figure 1. Alternator Resilient Mount (MEP-501A).

END OF TASK

END OF WORK PACKAGE

FIELD MAINTENANCE**2 kW MEP-501A/531A MILITARY TACTICAL GENERATOR SETS****CYLINDER HEAD NUTS TIGHTENING: ADJUSTMENT**

INITIAL SETUP:**Tools and Special Tools**

Tool Kit, General Mechanic's Automotive or Standard Automotive Tool Set (WP 0159, Table 2, Item 6)
Shop Equipment, Automotive Maintenance and Repair, Field Maintenance, Suppl 1 W/O Power (WP 0159, Table 2, Item 4)

Materials/Parts

As required

References

WP 0005, Operation Under Usual Conditions

Equipment Condition

Generator set shut down (WP 0005, Stopping Procedure)
Cable disconnected for NATO Slave Receptacle (WP 0005)

WARNING

The fuels in this generator set are flammable. Do not smoke or use open flames when performing maintenance. Do not service or drain the fuel system while open flames are present. Flames and explosion could result in severe personal injury or death. Use a container or cloth to catch any excess fuel to prevent spilling over engine components. Be sure to properly dispose of diesel fuel and diesel fuel soaked cloths.

ADJUSTMENT

1. Shut down generator set.
2. Remove bolts securing valve cover (Figure 1). Then remove valve cover with gasket.
3. Back off fuel line connecting nut from fuel injector. Do not disconnect line.
4. Loosen cylinder head nuts, then cross torque cylinder head nuts to 20-23 ft•lb (27-31 N•m).
5. Install gasket and valve cover on cylinder head with bolts.
6. Tighten fuel line connecting nut and bleed fuel system if necessary. Refer to WP 0005, Priming and Bleeding the Fuel System.

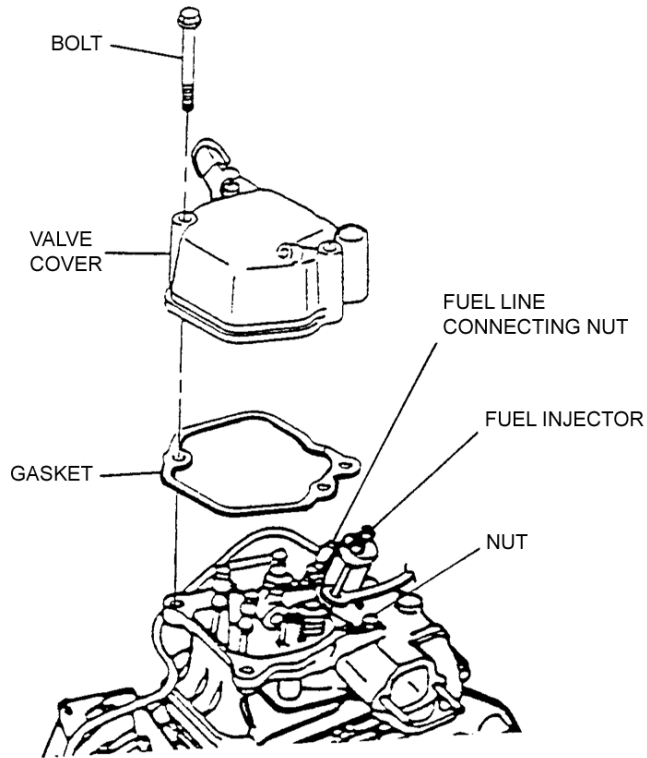

Figure 1. Torquing Cylinder Head Nuts.

END OF TASK

END OF WORK PACKAGE

FIELD MAINTENANCE

**2 kW MEP-501A/531A MILITARY TACTICAL GENERATOR SETS
FUEL LINES, CLAMPS, FITTINGS, ETC.: REMOVAL, INSTALLATION**

INITIAL SETUP:**Tools and Special Tools**

Tool Kit, General Mechanic's Automotive or Standard Automotive Tool Set (WP 0159, Table 2, Item 6)
Shop Equipment, Automotive Maintenance and Repair, Field Maintenance, Suppl 1 W/O Power (WP 0159, Table 2, Item 4)

Materials/Parts

As required

References

WP 0005, Operation Under Usual Conditions
WP 0028, Figure 1

Equipment Condition

Generator set shut down (WP 0005, Stopping Procedure)
Cable disconnected for NATO Slave Receptacle (WP 0005)
Fuel Tank drained: 1.6 gal (6.1 L) into suitable container

WARNING

The fuels in this generator set are flammable. Do not smoke or use open flames when performing maintenance. Do not service or drain the fuel system while open flames are present. Flames and explosion could result in severe personal injury or death. Use a container or cloth to catch any excess fuel to prevent spilling over engine components. Be sure to properly dispose of diesel fuel and diesel fuel soaked cloths.

REMOVAL

1. Shut down generator set.

NOTE

If removing tank-to-filter fuel line tubing, fuel tank must be drained.

2. If necessary, open fuel tank drain cock (WP 0028, Figure 1) and drain fuel into suitable container. Close fuel tank drain cock. Fuel tank capacity is 1.6 gal. (6.1 L).

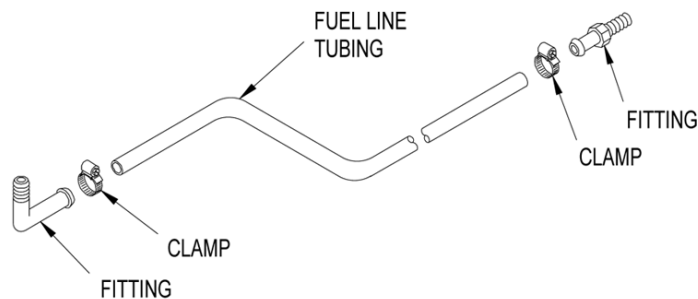

Figure 1. Fuel Lines, Clamps, Fittings (Typical).

3. Loosen hose clamps (Figure 1) and remove fuel line tubing.

4. Remove fittings as necessary.

END OF TASK**INSTALLATION**

1. Install fittings (Figure 1) as necessary.
2. Install fuel line tubing and tighten clamps.

NOTE

This generator set can operate on DL-1, DL-2 & JP-8.
No adjustments are necessary to run these alternate fuels.

3. If drained, fill fuel tank with diesel fuel (DL-1, DL-2, or JP-8).
4. Prime and bleed the fuel system. Refer to WP 0005, Priming and Bleeding the Fuel System.

END OF TASK**END OF WORK PACKAGE**

FIELD MAINTENANCE**2 kW MEP-501A/531A MILITARY TACTICAL GENERATOR SETS
FUEL FILTER ASSEMBLY: REMOVAL, INSPECTION, INSTALLATION**

INITIAL SETUP:**Tools and Special Tools**

Tool Kit, General Mechanic's Automotive or Standard Automotive Tool Set (WP 0159, Table 2, Item 6)

Materials/Parts

As required

References

WP 0005, Operation Under Usual Conditions
WP 0028, Figure 1

Equipment Condition

Generator set shut down (WP 0005, Stopping Procedure)
Cable disconnected for NATO Slave Receptacle (WP 0005)
Fuel Tank drained: 1.6 gal (6.1 L) into suitable container

WARNING

The fuels in this generator set are flammable. Do not smoke or use open flames when performing maintenance. Do not service or drain the fuel system while open flames are present. Flames and explosion could result in severe personal injury or death. Use a container or cloth to catch any excess fuel to prevent spilling over engine components. Be sure to properly dispose of diesel fuel and diesel fuel soaked cloths.

REMOVAL**NOTE**

For generator sets with the original Mechtron configuration fuel filter assembly, replace entire assembly with the assembly listed in this manual. Shorten fuel line from fuel tank to fuel filter assembly by approximately two (2) inches to reduce slack in fuel line.

1. Shut down generator set.
2. Open fuel tank drain cock (see WP 0028, Figure 1) and drain fuel into suitable container, and close fuel tank drain cock. Fuel tank capacity is 1.6 gal. (6.1 L).
3. Loosen hose clamps (Figure 1, Items 1 and 3) and disconnect tank-to-filter and filter-to-pump fuel line tubing (2 and 4) from fuel filter assembly.
4. Remove nut (5), lockwasher (6), washer (7), capscrew (8), and washer (9) securing fuel filter assembly (10) to bracket (16).
5. Remove fuel filter assembly (10) with washer (11) using care not to spill diesel fuel trapped in filter bowl.
6. If necessary, remove bolts and capscrew (12, 14, and 17) and lockwashers (13 and 15) securing bracket (16) and stiffener (18) to diesel engine.

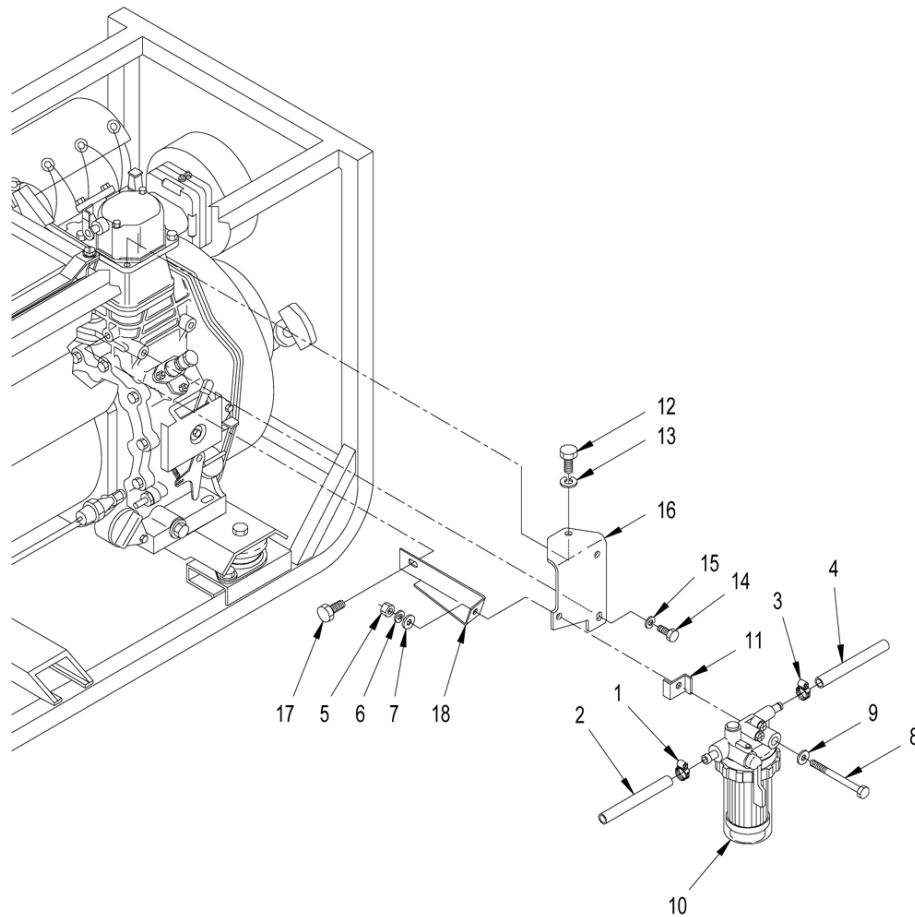

LEGEND

- | | | | |
|---|------------|----|----------------------|
| 1 | Hose Clamp | 10 | Fuel Filter Assembly |
| 2 | Tubing | 11 | Washer |
| 3 | Hose Clamp | 12 | Bolt |
| 4 | Tubing | 13 | Lockwashers |
| 5 | Nut | 14 | Capscrew |
| 6 | Lockwasher | 15 | Lockwashers |
| 7 | Washer | 16 | Bracket |
| 8 | Capscrew | 17 | Bolt |
| 9 | Washer | 18 | Stiffener |

Figure 1. Fuel Filter Assembly.

END OF TASK

INSPECTION

1. Check fuel filter assembly (Figure 1, Item 10) for nicks, cracks, or leaks. Replace if damaged.
2. Inspect bracket (16) and stiffener (18) for cracks and deformation.

END OF TASK

INSTALLATION

1. If removed, install bracket (Figure 1, Item 16) and stiffener (18) to diesel engine with bolts and capscrew (12, 14, and 17) and lockwashers (13 and 15).

2. Install fuel filter assembly (10) on bracket (16) and secure with capscrew (8), washer (9), washer (11), washer (7), lockwasher (6), and nut (5).
3. Connect tank-to-filter and filter-to-pump fuel line tubing (2 and 4) to fuel filter assembly (10). Tighten hose clamps (1 and 3).

NOTE

This generator set can operate on DL-1, DL-2 & JP-8.
No adjustments are necessary to run these alternate fuels.

4. Fill fuel tank with diesel fuel (DL-1, DL-2, or JP-8).
5. Prime and bleed the fuel system. Refer to WP 0005, Priming and Bleeding the Fuel System.

END OF TASK

END OF WORK PACKAGE

FIELD MAINTENANCE**2 kW MEP-501A/531A MILITARY TACTICAL GENERATOR SETS****FUEL DRAIN COCK: REMOVAL, INSTALLATION****INITIAL SETUP:****Tools and Special Tools**

Tool Kit, General Mechanic's Automotive or Standard Automotive Tool Set (WP 0159, Table 2, Item 6)

Materials/Parts

Sealing Compound (WP 0162, Table 1, Item 21)

References

WP 0005, Operation Under Usual Conditions
WP 0162, Table 1, Item 21

Equipment Condition

Generator set shut down (WP 0005, Stopping Procedure)
Cable disconnected for NATO Slave Receptacle (WP 0005)
Fuel Tank drained: 1.6 gal (6.1 L) into suitable container

WARNING

The fuels in this generator set are flammable. Do not smoke or use open flames when performing maintenance. Do not service or drain the fuel system while open flames are present. Flames and explosion could result in severe personal injury or death. Use a container or cloth to catch any excess fuel to prevent spilling over engine components. Be sure to properly dispose of diesel fuel and diesel fuel soaked cloths.

REMOVAL

1. Shut down generator set.
2. Open fuel tank drain cock (Figure 1), drain fuel into suitable container. Fuel tank capacity is 1.6 gal. (6.1 L).

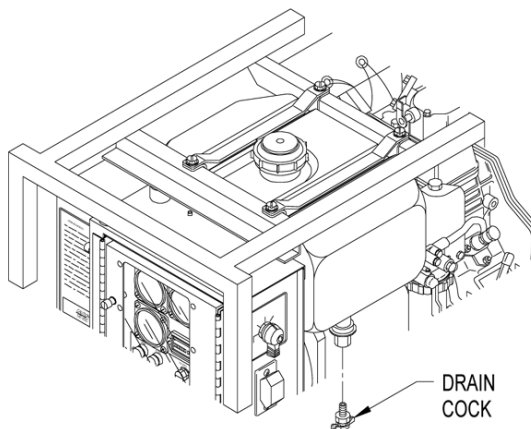

Figure 1. Fuel Drain Cock.

3. Remove drain cock.

END OF TASK

INSTALLATION

1. Apply sealing compound (WP 0162, Table 1, Item 21) to threads of drain cock and adapter.
2. Install drain cock (Figure 1).

NOTE

This generator set can operate on DL- 1, DL- 2 & JP-8.

No adjustments are necessary to run these alternate fuels.

3. Fill fuel tank with diesel fuel (DL-1, DL-2, or JP-8).
4. Prime and bleed the fuel system. Refer to WP 0005, Priming and Bleeding the Fuel System.

END OF TASK**END OF WORK PACKAGE**

FIELD MAINTENANCE**2 kW MEP-501A/531A MILITARY TACTICAL GENERATOR SETS****FUEL TANK ASSEMBLY: REMOVAL, DISASSEMBLY, INSPECTION, ASSEMBLY, INSTALLATION**

INITIAL SETUP:**Tools and Special Tools**

Tool Kit, General Mechanic's Automotive or Standard Automotive Tool Set (WP 0159, Table 2, Item 6)
Shop Equipment, Automotive Maintenance and Repair, Field Maintenance, Suppl 1 W/O Power (WP 0159, Table 2, Item 4)

Materials/Parts

Solvent, Cleaning (WP 0162, Table 1, Item 20)
Cloth, Cleaning (WP 0162, Table 1, Item 4)

References

WP 0005, Operation Under Usual Conditions
WP 0162, Table 1, Item 1, 4, and 20

Equipment Condition

Generator set shut down (WP 0005, Stopping Procedure)
Cable disconnected for NATO Slave Receptacle (WP 0005)
Fuel Tank drained: 1.6 gal (6.1 L) into suitable container

WARNING

The fuels in this generator set are flammable. Do not smoke or use open flames when performing maintenance. Do not service or drain the fuel system while open flames are present. Flames and explosion could result in severe personal injury or death. Use a container or cloth to catch any excess fuel to prevent spilling over engine components. Be sure to properly dispose of diesel fuel and diesel fuel soaked cloths.

WARNING

Cleaning solvents are flammable and toxic to eyes, skin, and respiratory tract. Skin/eye protection required. Avoid repeated/prolonged contact. Good general ventilation is normally adequate.

WARNING

Adhesive is flammable and toxic. Vapors may ignite explosively. Avoid breathing in vapors. Provide adequate ventilation to prevent vapor concentrations in excess of permissible exposure levels. Keep away from heat, sparks, and open flame. Do not smoke. Extinguish all flames and turn off non-explosion-proof electrical equipment during use until vapors are dissipated. Close container tightly after use. Contains Methylethketone. Avoid swallowing.

REMOVAL**NOTE**

For generator sets with Mechron configuration fuel tank. Replace fuel tank with assembly listed in this manual. Replacement tank will come with fuel drain cock installed.

1. Shut down generator set.
2. Open fuel tank drain cock (Figure 1, Item 14) and drain fuel into suitable container. Close fuel tank drain cock. Fuel tank capacity is 1.6 gal. (6.1 L).
3. Loosen hose clamp (1) and disconnect tank-to-filter fuel line tubing (2) from elbow (16) at bottom of fuel tank (9).
4. Loosen hose clamp (3) and disconnect return fuel line tubing (4) from elbow (18) at front of fuel tank (9).

5. Remove capscrews (5), lockwashers (6), washers (7), and upper fuel tank brackets (8).
6. Remove fuel tank (9) from lower fuel tank brackets (10).
7. Remove lower fuel tank brackets (10) and guard (11) from generator set frame.

END OF TASK

DISASSEMBLY

1. Remove fuel cap (Figure 1, Item 12) and filter (13) from fuel tank (9).
2. Remove fuel drain cock (14) from adapter (15).
3. Remove adapter (15) from fuel tank by holding adapter top plate with pliers and turning adapter fitting. Refer to Detail A.

NOTE

Some fuel tanks may be equipped with a fuel drain adapter requiring removal from inside the tank and secured with a nut on the outside of the tank.

4. Remove elbows (16 and 18) from bushings (17 and 19), and bushings from fuel tank.
5. If necessary, remove rubber straps (20) from fuel tank. Remove all traces of adhesive from tank.

END OF TASK

INSPECTION

1. Inspect fuel tank brackets (Figure 1, Items 8 and 10) for damage that would prevent them from securely holding fuel tank.

WARNING

Cleaning solvents are flammable and toxic to eyes, skin, and respiratory tract. Skin/eye protection required. Avoid repeated/prolonged contact. Good general ventilation is normally adequate.

2. Visually check fuel tank (9) for cracks or leaks. Ensure that fuel cap (12) fits securely onto tank and surrounding area is clean. Clean using approved cleaning solvent (WP 0162, Table 1, Item 20) and cleaning cloth (WP 0162, Table 1, Item 4).
3. Check filter (13) for cracks or damage. Replace if defective.
4. Inspect fuel cap (12) for physical damage. Repair or replace as necessary.
5. Inspect fuel drain cock (14) and adapter (15) for damage and leaks. Replace if defective.
6. Inspect elbows (16 and 18) and bushings (17 and 19) for physical damage, leaks, and security.

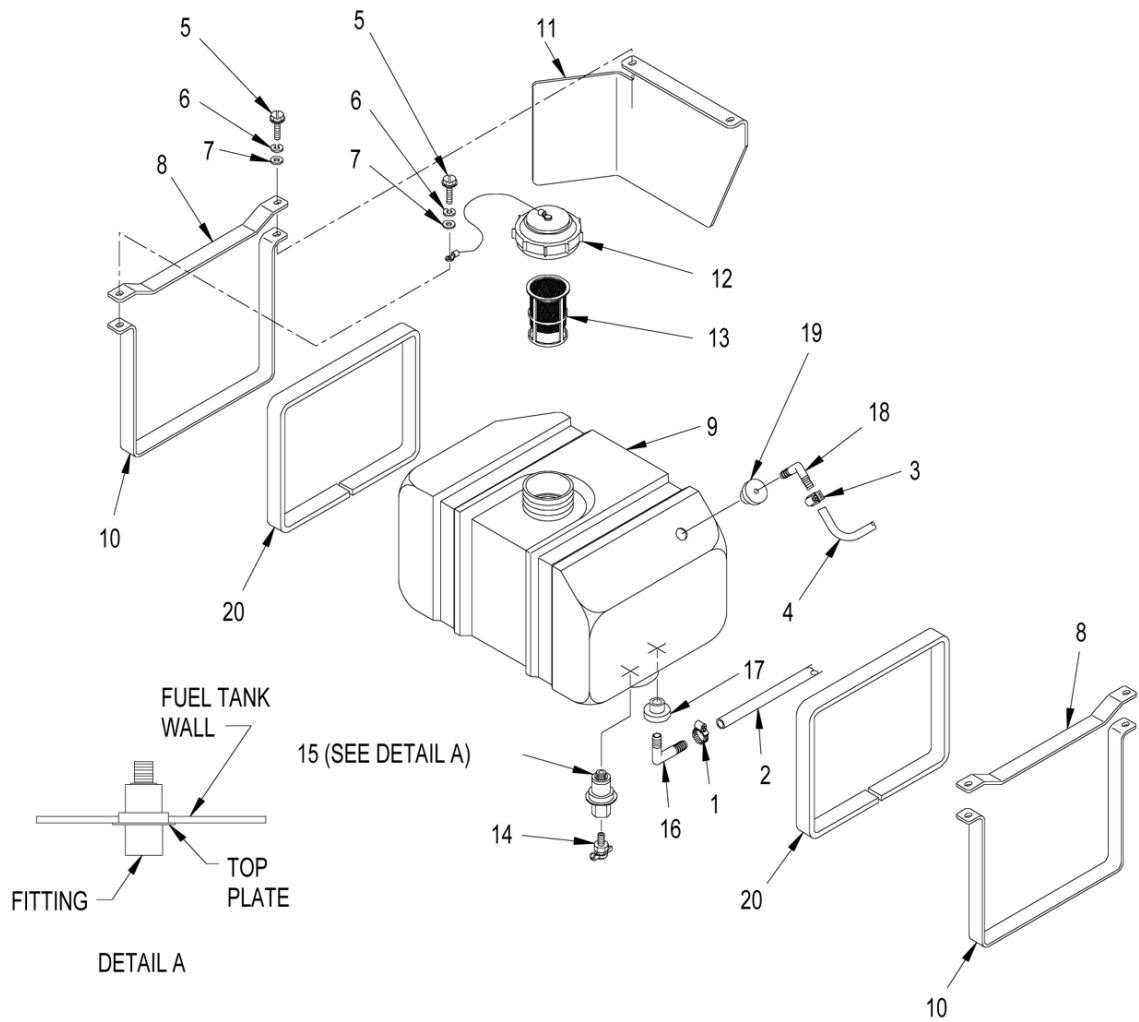

LEGEND

- | | | | |
|----|------------|----|--------------|
| 1 | Hose Clamp | 11 | Guard |
| 2 | Tubing | 12 | Fuel Cap |
| 3 | Hose Clamp | 13 | Filter |
| 4 | Tubing | 14 | Drain Cock |
| 5 | Capscrew | 15 | Adapter |
| 6 | Lockwasher | 16 | Elbow |
| 7 | Washer | 17 | Bushing |
| 8 | Bracket | 18 | Elbow |
| 9 | Fuel Tank | 19 | Bushing |
| 10 | Bracket | 20 | Rubber Strap |

Figure 1. Fuel Tank Assembly.

END OF TASK

ASSEMBLY**WARNING**

Adhesive is flammable and toxic. Vapors may ignite explosively. Avoid breathing in vapors. Provide adequate ventilation to prevent vapor concentrations in excess of permissible exposure levels. Keep away from heat, sparks, and open flame. Do not smoke. Extinguish all flames and turn off non-explosion-proof electrical equipment during use until vapors are dissipated. Close container tightly after use. Contains Methylethketone. Avoid swallowing.

1. If removed, install rubber straps (Figure 1, Item 20) on fuel tank (9). Make sure fuel tank is clean and free of oil, dirt, and grease. Then cut rubber straps and secure with adhesive (WP 0162, Table 1, Item 1). Follow adhesive manufacturer' s instructions for application.
2. Install bushings (19 and 17) in fuel tank (9), and elbows (18 and 16) in bushings.
3. Install adapter (15) in fuel tank (9). Torque adapter to 40 in•lb (4.5 N•m), then install fuel drain cock (14) in adapter.
4. Install filter (13) and fuel cap (12) on fuel tank (9).

END OF TASK**INSTALLATION**

1. Position guard (Figure 1, Item 11) and lower fuel tank brackets (10) in generator set frame.
2. Place fuel tank (9) in lower fuel tank brackets (10).
3. Secure fuel tank (9) in generator set with upper fuel tank brackets (8), washers (7), lockwashers (6), and capscrews (5) ensuring fuel cap (12) wire rope is secured under rear right side hardware.
4. Connect fuel return line tubing (4) to elbow (18) with hose clamp (3).
5. Connect tank-to-filter fuel line tubing (2) to elbow (16) with hose clamp (1).

NOTE

This generator set can operate on DL- 1, DL- 2 & JP8.
No adjustments are necessary to run alternate fuels.

6. Fill fuel tank with diesel fuel (DL-1, DL-2, or JP-8).
7. Prime and bleed the fuel system. Refer to WP 0005, Priming and Bleeding the Fuel System.

END OF TASK**END OF WORK PACKAGE**

FIELD MAINTENANCE

2 kW MEP-501A/531A MILITARY TACTICAL GENERATOR SETS

AIR INTAKE SYSTEM COMPONENTS: REMOVAL, INSPECTION, INSTALLATION

INITIAL SETUP:

Tools and Special Tools

Tool Kit, General Mechanic's Automotive or Standard Automotive Tool Set (WP 0159, Table 2, Item 6)

Materials/Parts

Compound, Locking (WP 0162, Table 1, Item 7)
Oil, Lubricating (WP 0162, Table 1, Item 14)

References

WP 0162, Item 7, and 15

Equipment Condition

Generator set shut down (WP 0005, Stopping Procedure)
Cable disconnected for NATO Slave Receptacle (WP 0005)

REMOVAL

1. Shut down generator set.
2. Remove wing nut (Figure 1), cover, and filter element with pre-filter.

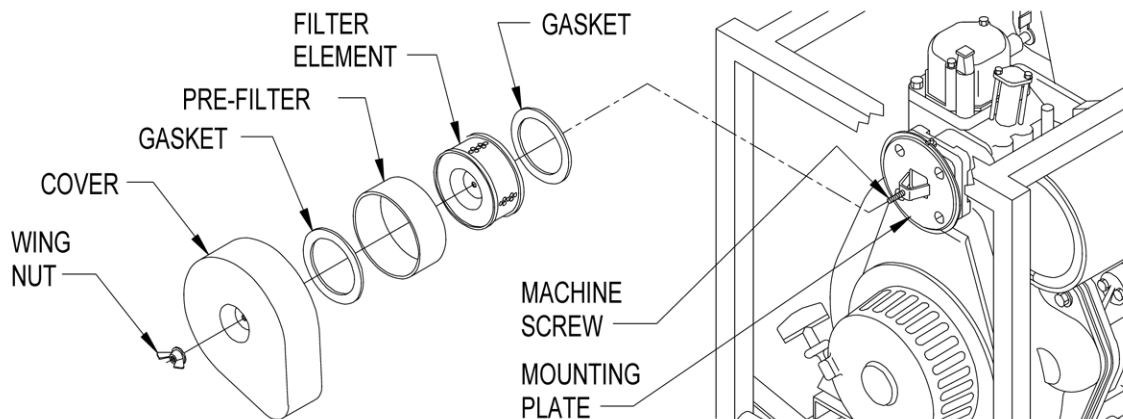

Figure 1. Air Intake System Components.

3. Remove pre-filter from filter element.
4. If necessary, remove gaskets from mounting plate and cover. Clean adhesive residue from surfaces.

END OF TASK

INSPECTION

1. Inspect cover (Figure 1) for cleanliness, cracks and other damage. Clean cover with mild soap and water.
2. Inspect filter element for cleanliness, dents, and crushed corrugations. Replace if damaged.
3. Discard pre-filter.
4. Replace damaged parts.

5. If damaged, replace machine screw in mounting plate. Use locking compound (WP 0162, Table 1, Item 7) to secure machine screw in mounting plate.

END OF TASK**INSTALLATION**

1. If removed, install new gasket (Figure 1) on cover.
2. Position air filter element on mounting plate and mark position for gasket on plate. Remove air filter element and install new gasket on mounting plate with adhesive side toward mounting plate.
3. Soak new pre-filter in clean engine oil (WP 0162, Table 1, Item 15) and squeeze out ALL excess oil.
4. Install pre-filter over filter element. Pre-filter should fit snugly over filter element.
5. Position filter element with pre-filter and cover on mounting plate.
6. Install wing nut.

END OF TASK**END OF WORK PACKAGE**

FIELD MAINTENANCE**2 kW MEP-501A/531A MILITARY TACTICAL GENERATOR SETS****EXHAUST SYSTEM COMPONENTS: REMOVAL, CLEANING, INSTALLATION**

INITIAL SETUP:**Tools and Special Tools**

Tool Kit, General Mechanic's Automotive or Standard Automotive Tool Set (WP 0159, Table 2, Item 6)
Shop Equipment, Automotive Maintenance and Repair, Field Maintenance, Suppl 1 W/O Power (WP 0159, Table 2, Item 4)

Materials/Parts

Solvent, Cleaning (WP 0162, Table 1, Item 20)

References

WP 0162, Table 1, Item 20

Equipment Condition

Generator set shut down (WP 0005, Stopping Procedure)
Cable disconnected for NATO Slave Receptacle (WP 0005)

WARNING

Cleaning solvents are flammable and toxic to eyes, skin, and respiratory tract. Skin/eye protection required. Avoid repeated/prolonged contact. Good general ventilation is normally adequate.

REMOVAL

1. Shut down generator set.
2. Remove clamp (Figure 1, Item 1) and spark arrester (2) from muffler (11).
3. Cut retaining wire (3) and remove retaining wire and blanket (4) from shroud (5).
4. Remove capscrews (6), lockwashers (7), washers (8), and shroud (5) from muffler (11).
5. If necessary, remove grommet (13) from shroud (5).
6. If necessary, remove capscrews (9), nuts (10), muffler (11), and gasket (12).

END OF TASK**CLEANING****NOTE**

Spark arrester diffuser discs can become blocked with carbon deposits over time, making engine hard to start. Disassemble and clean spark arrester as necessary to ensure proper operation.

1. Remove socket head screws (Figure 1, Item 14), end cap (15), and diffuser discs (16) from spark arrester (2).

WARNING

Cleaning solvents are flammable and toxic to eyes, skin, and respiratory tract. Skin/eye protection required. Avoid repeated/prolonged contact. Good general ventilation is normally adequate.

2. Clean carbon deposits from diffuser discs, end cap, and spark arrester using a wire brush and approved cleaning solvent (WP 0162, Table 1, Item 20).
3. Install diffuser discs (16) and end cap (15) on spark arrester with socket head screws (14).

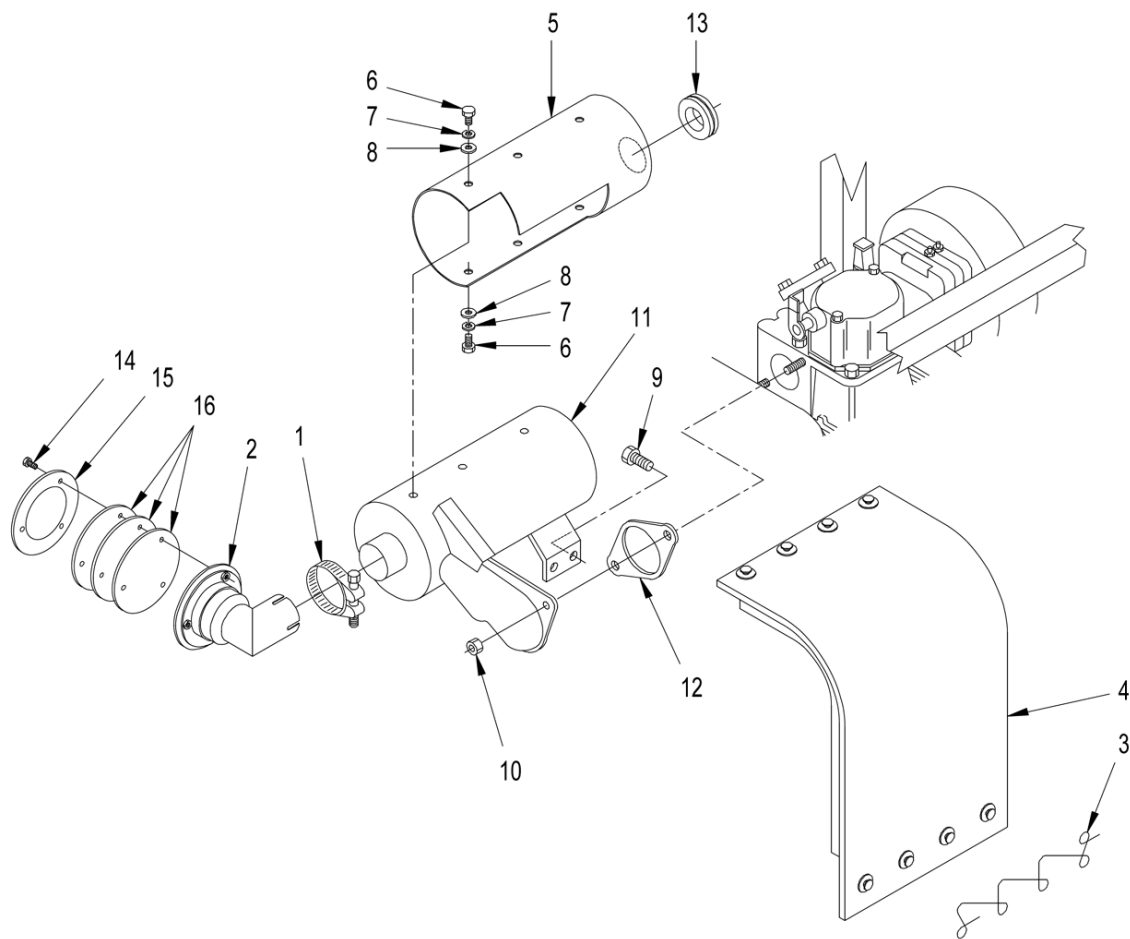
**LEGEND**

1	Clamp	9	Capscrew
2	Spark arrester	10	Nut
3	Retaining Wire	11	Muffler
4	Blanket	12	Gasket
5	Shroud	13	Grommet
6	Capscrew	14	Socket Head Screw
7	Lockwasher	15	End Cap
8	Washer	16	Diffuser Disc

Figure 1. Exhaust System Components.**END OF TASK****INSTALLATION**

1. If removed, install new gasket (Figure 1, Item 12) and muffler (11) with nuts (10), and capscrews (9). Torque capscrews (9) to 125 in•lb (14 N•m) and nuts (10) to 225 in•lb (25 N•m).
2. If removed, install grommet (13) in shroud (5).
3. Install shroud (5) on muffler with washers (8), lockwashers (7), and capscrews (6).
4. Install muffler blanket (4) over shroud (5). Secure with retaining wire (3).
5. Install spark arrester (2) on muffler and secure with clamp (1). Refer to Figure 2 for proper positioning of clamp. Torque clamp bolt to 150 in•lb (17 N•m).

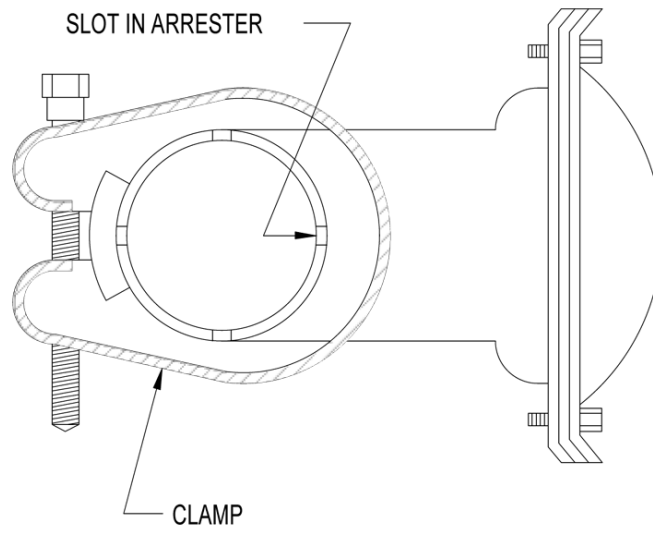

Figure 2. Spark Arrester Clamp Positioning.

END OF TASK

END OF WORK PACKAGE

FIELD MAINTENANCE**2 kW MEP-501A/531A MILITARY TACTICAL GENERATOR SETS****CONTROL PANEL ASSEMBLY: INSPECTION, REMOVAL, REPAIR, INSTALLATION**

INITIAL SETUP:**Tools and Special Tools**

Tool Kit, General Mechanic's Automotive or Standard Automotive Tool Set (WP 0159, Table 2, Item 6)
Shop Equipment, Automotive Maintenance and Repair, Field Maintenance, Suppl 1 W/O Power (WP 0159, Table 2, Item 4)

References

WP 0162, Table 1, Item 17
TM 43-1039/TO 35-1-3

Materials/Parts

Paper, Abrasive (WP 0162, Table 1, Item 17)

Equipment Condition

Generator set shut down (WP 0005, Stopping Procedure)
Cable disconnected for NATO Slave Receptacle (WP 0005)
Low Oil Pressure (LOP) Engine Shutdown Cable removed (WP 0062)

WARNING

Chemical Agent Resistant Coating (CARC) paint dust is a health hazard. Wear protective eyewear, mask, and gloves when sanding CARC painted surfaces. Failure to comply can cause personal injury.

INSPECTION

1. Shut down generator set.
2. Inspect control panel assembly for security, cracked and corroded panels, loose wires, missing parts, and other damage.

END OF TASK**REMOVAL**

1. Shut down generator set.
2. Unscrew and disconnect engine and alternator harness plugs (Figure 1) from receptacles at bottom of control panel assembly.
3. Remove nut, lockwasher, and ground strap from frame.
4. Remove LOP engine shutdown cable from control panel assembly, refer to WP 0062, Removal, Step 5 only.
5. Remove locknuts that hold control panel assembly to frame.
6. Remove control panel assembly from frame.

END OF TASK

REPAIR**WARNING**

Chemical Agent Resistant Coating (CARC) paint dust is a health hazard. Wear protective eyewear, mask, and gloves when sanding CARC painted surfaces. Failure to comply can cause personal injury.

1. Repair all dents and cracks, and remove all loose paint.
2. Remove light corrosion with fine grit abrasive paper (WP 0162, Table 1, Item 17).
3. Repaint surface in accordance with TM 43-0139/TO 35-1-3.

END OF TASK**INSTALLATION**

1. Position control panel assembly (Figure 1) in frame.

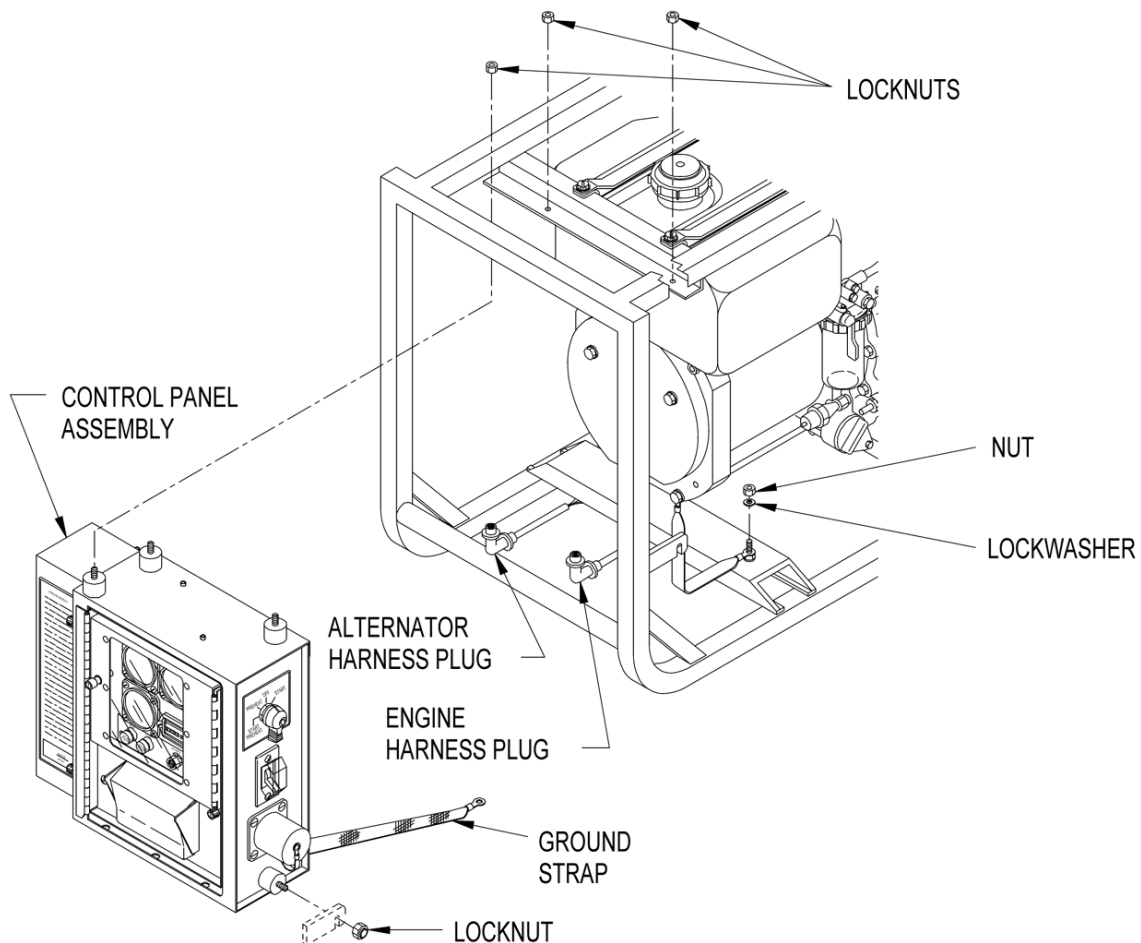

Figure 1. Control Panel Assembly.

2. Install locknuts to secure control panel assembly.
3. Install LOP engine shutdown cable in control panel assembly, refer to WP 0062, Installation, Steps 5 and 6 only.

4. Connect ground strap to frame with lockwasher and nut. Torque nut to 75 in•lb (8.5 N•m).
5. Connect engine and alternator harness plugs to receptacles at bottom of control panel assembly.

END OF TASK

END OF WORK PACKAGE

FIELD MAINTENANCE**2 kW MEP-501A/531A MILITARY TACTICAL GENERATOR SETS****INSTRUCTION PLATE(S): REMOVAL, INSTALLATION**

INITIAL SETUP:**Tools and Special Tools**

Tool Kit, General Mechanic's Automotive or
Standard Automotive Tool Set
(WP 0159, Table 2, Item 6)

Materials/Parts

As required

Equipment Condition

Generator set shut down (WP 0005, Stopping
Procedure)
Cable disconnected for NATO Slave Receptacle
(WP 0005)

REMOVAL

1. Drill out rivets (Figure 1) securing instruction plate to control panel assembly.
2. Remove instruction plate.

END OF TASK**INSTALLATION**

1. Using new instruction plate (Figure 1) as a template, drill six new 1/16-in. holes in control panel assembly if necessary.
2. Secure instruction plate with rivets.

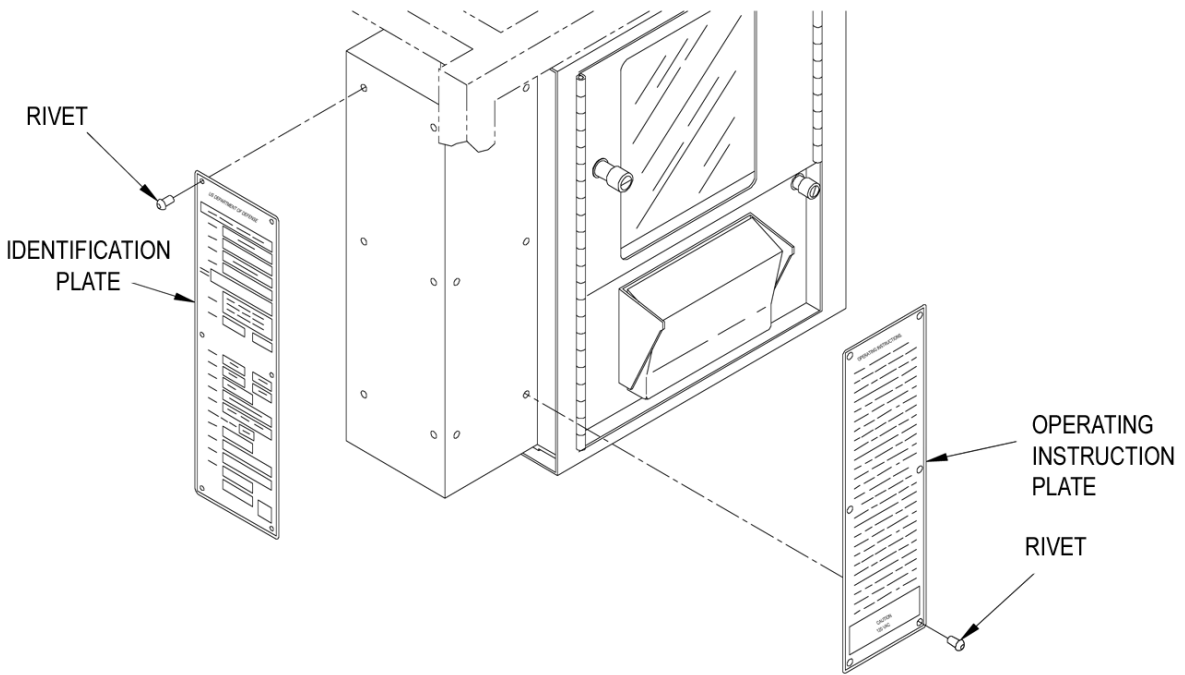

Figure 1. Instruction Plate(s).

END OF TASK

END OF WORK PACKAGE

FIELD MAINTENANCE**2 kW MEP-501A/531A MILITARY TACTICAL GENERATOR SETS**
INSTRUMENT COVER: INSPECTION, REMOVAL, REPAIR, INSTALLATION

INITIAL SETUP:**Tools and Special Tools**

Tool Kit, General Mechanic's Automotive or Standard Automotive Tool Set (WP 0159, Table 2, Item 6)

Materials/Parts

Paper, Abrasive (WP 0162, Table 1, Item 17)

References

WP 0162, Table 1, Item 7
TM 43-0139/TO 35-1-3

Equipment Condition

Generator set shut down (WP 0005, Stopping Procedure)
Cable disconnected for NATO Slave Receptacle (WP 0005)

WARNING

Chemical Agent Resistant Coating (CARC) paint dust is a health hazard. Wear protective eyewear, mask, and gloves when sanding CARC painted surfaces. Failure to comply can cause personal injury.

INSPECTION

1. Shut down generator set.
2. Inspect instrument cover for security, cracks, corrosion, and other damage.

END OF TASK**REMOVAL**

1. Shut down generator set.
2. Release instrument panel by turning fastener. Open instrument panel slowly.
3. Release instrument cover by turning fastener. Open instrument cover.
4. Remove rivets (Figure 1) and instrument cover from instrument panel.
5. If necessary, remove nut, lockwasher, washer, and standoff from instrument panel.

END OF TASK**REPAIR****WARNING**

Chemical Agent Resistant Coating (CARC) paint dust is a health hazard. Wear protective eyewear, mask, and gloves when sanding CARC painted surfaces. Failure to comply can cause personal injury.

1. Repair all dents and cracks, and remove all loose paint.
2. Remove light corrosion with fine grit abrasive paper (WP 0162, Table 1, Item 17).
3. Repaint surface in accordance with TM 43-0139/TO 35-1-3.

END OF TASK

INSTALLATION

1. If removed, install standoff (Figure 1) on instrument panel with washer, lockwasher, and nut.
2. Install instrument cover on instrument panel with new rivets.
3. Close and secure instrument panel and instrument cover.

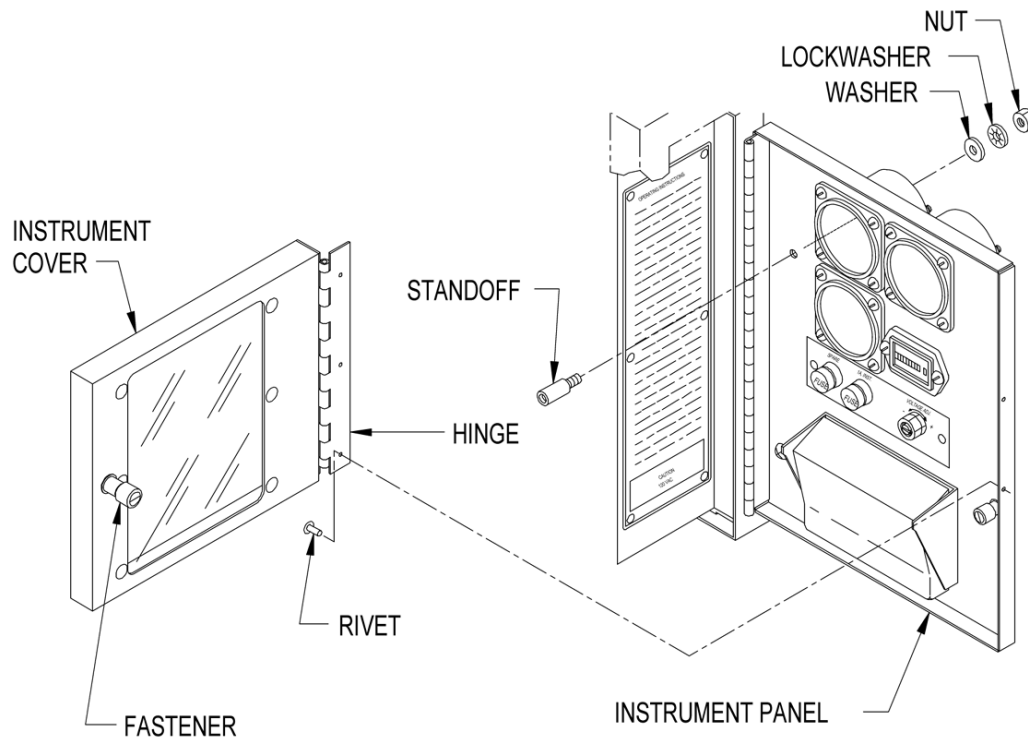
**Figure 1. Instrument Cover.****END OF TASK****END OF WORK PACKAGE**

FIELD MAINTENANCE**2 kW MEP-501A/531A MILITARY TACTICAL GENERATOR SETS****INSTRUMENT PANEL: INSPECTION, REMOVAL, REPAIR, INSTALLATION**

INITIAL SETUP:**Tools and Special Tools**

Tool Kit, General Mechanic's Automotive or Standard Automotive Tool Set (WP 0159, Table 2, Item 6)

Materials/Parts

Paper, Abrasive (WP 0162, Table 1, Item 17)

References

WP 0034, Instrument Cover
WP 0162, Table 1, Item 17
TM 43-0139/TO 35-1-3

Equipment Condition

Generator set shut down (WP 0005, Stopping Procedure)
Cable disconnected for NATO Slave Receptacle (WP 0005)
Instrument cover removed, if necessary (WP 0034)

WARNING

Chemical Agent Resistant Coating (CARC) paint dust is a health hazard. Wear protective eyewear, mask, and gloves when sanding CARC painted surfaces. Failure to comply can cause personal injury.

INSPECTION

1. Shut down generator set.
2. Inspect instrument panel for security, cracks and other damage.

END OF TASK**REMOVAL**

1. Shut down generator set.
2. Release instrument panel by turning fastener. Open instrument panel slowly.
3. Remove nut (Figure 1), lockwasher, washer, and screw securing clamp and ground strap to instrument panel.
4. If necessary, remove clamp from electrical harness and ground strap from lug terminal board mounting screw.
5. Remove gauge protective cover. Then tag and disconnect electrical leads from HERTZ frequency meter (MEP-531 only), VOLTS meter, % LOAD meter, HOURS meter, VOLTAGE ADJ. potentiometer, GFCI receptacle (MEP-531 only), and INST. fuse holder.
6. Remove rivets and instrument panel from control panel.
7. If necessary, remove fastener from instrument panel and blind nut from control panel.
8. If necessary, remove edge protector and adhesive residue from control panel.
9. If necessary, remove instrument cover, refer to WP 0034, Removal.
10. If necessary, remove HERTZ frequency meter (MEP-531A only), VOLTS meter, % LOAD meter, HOURS meter, VOLTAGE ADJ. potentiometer, GFCI receptacle (MEP-531A only), and INST. fuse holders, see table of contents for corresponding work packages.
11. If necessary, remove rivets and instruction plate.

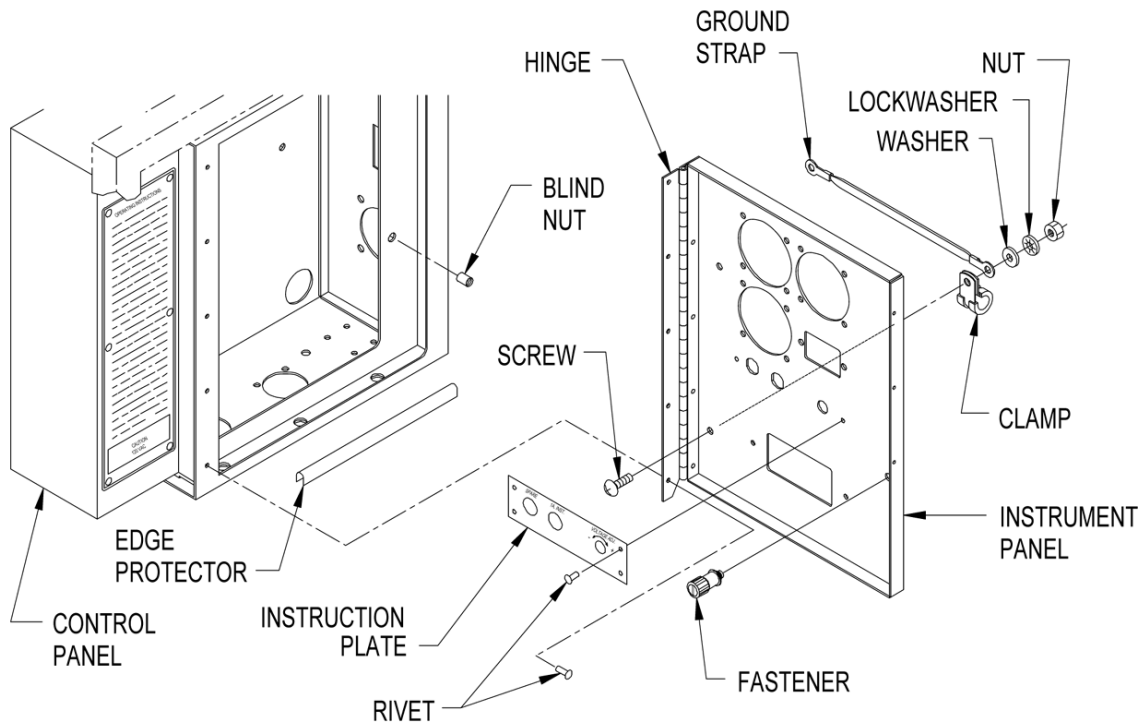

Figure 1. Instrument Panel.

END OF TASK

REPAIR

WARNING

Chemical Agent Resistant Coating (CARC) paint dust is a health hazard. Wear protective eyewear, mask, and gloves when sanding CARC painted surfaces. Failure to comply can cause personal injury.

1. Repair all dents and cracks, and remove all loose paint.
2. Remove light corrosion with fine grit abrasive paper (WP 0162, Table 1, Item 17).
3. Repaint surface in accordance with TM 43-0139/TO 35-1-3.

END OF TASK

INSTALLATION

1. If removed, install instruction plate, refer to WP 0033, Installation.
2. If removed, install INST. fuse holders, GFCI receptacle (MEP-531A only), VOLTAGE ADJ. potentiometer, HOURS meter, % LOAD meter, VOLTS meter, and HERTZ frequency meter (MEP-531A only). Refer to corresponding paragraphs.
3. If removed, install instrument cover, refer to WP 0034, Installation.
4. If removed, install edge protector (Figure 1) on control panel with contact adhesive (WP 0162, Table 1, Item 2).
5. If removed, install blind nut in control panel and fastener in instrument panel.
6. If removed, install hinge on instrument panel with new rivets.

7. Install instrument panel on control panel with new rivets.
8. If removed, install ground strap on lug terminal board mounting screw and position clamp on electrical harness.
9. Secure ground strap and clamp to instrument panel with screw, washer, lockwasher, and nut.
10. Connect electrical leads to HERTZ frequency meter (MEP-531 only), VOLTS meter, % LOAD meter, HOURS meter, VOLTAGE ADJ. potentiometer, GFCI receptacle (MEP-531 only), and INST. fuse holder. Remove tags. Then install gauge protective cover.
11. Close and secure instrument panel.

END OF TASK

END OF WORK PACKAGE

FIELD MAINTENANCE**2 kW MEP-501A/531A MILITARY TACTICAL GENERATOR SETS****HERTZ FREQUENCY METER (MEP-531A): INSPECTION, TESTING, REMOVAL, INSTALLATION**

INITIAL SETUP:**Tools and Special Tools**

Tool Kit, General Mechanic's Automotive or Standard Automotive Tool Set (WP 0159, Table 2, Item 6)
Multimeter (WP 0159, Table 2, Item 3)

Materials/Parts

Compound, Locking (WP 0162, Table 1, Item 7)

References

WP 0162, Table 1, Item 7

Equipment Condition

Generator set shut down (WP 0005, Stopping Procedure)
Cable disconnected for NATO Slave Receptacle (WP 0005)

INSPECTION

1. Shut down generator set.
2. Release instrument cover by turning fastener. Open instrument cover.
3. Release instrument panel by turning fastener. Open instrument panel slowly.
4. Inspect HERTZ frequency meter for security, cracked lens, corrosion, and other damage.
5. Close and secure instrument panel and instrument cover.

END OF TASK**TESTING**

1. Shut down generator set.
2. Release instrument panel by turning fastener. Open instrument panel slowly.
3. Remove gauge protective cover.
4. Set multimeter for ohms and check for continuity in wires M4-1⊗M2-1 and M4-2⊗M2-2.
5. If continuity is present (Step 4), replace HERTZ frequency meter.
6. Install gauge protective cover.
7. Close and secure instrument panel.

END OF TASK**REMOVAL**

1. Shut down generator set.
2. Release instrument panel by turning fastener. Open instrument panel slowly.
3. Remove gauge protective cover. Then tag and disconnect HERTZ frequency meter (Figure 1) electrical leads.

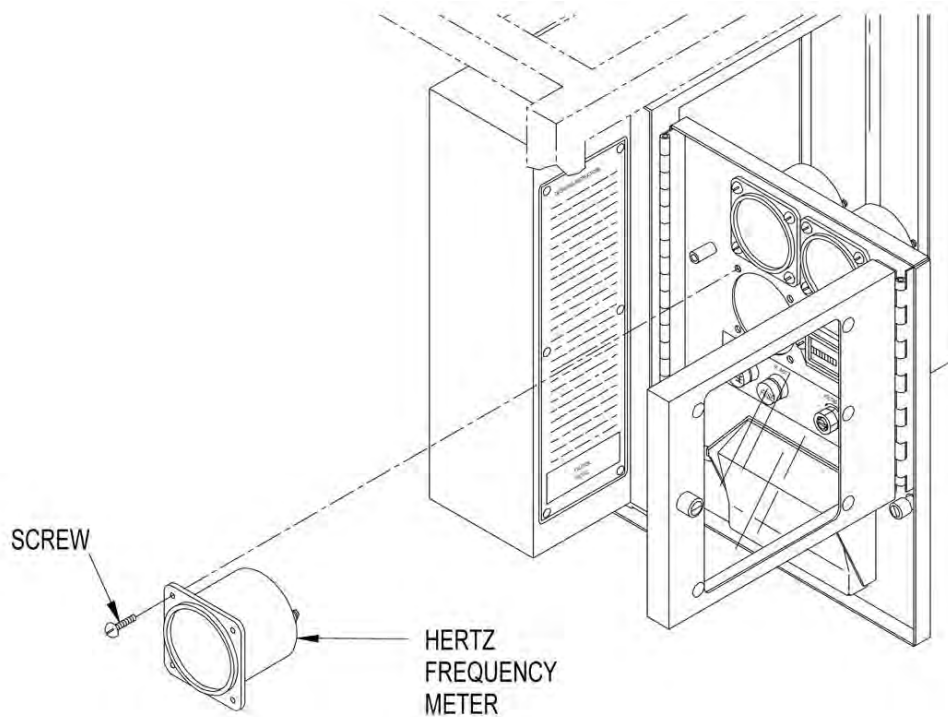

Figure 1. HERTZ Frequency Meter (MEP-531A).

4. Release instrument cover by turning fastener. Open instrument cover.
5. Remove screws.
6. Remove HERTZ frequency meter from instrument panel.

END OF TASK

INSTALLATION

1. Insert HERTZ frequency meter (Figure 1) into instrument panel.
2. Apply locking compound (WP 0162, Table 1, Item 7) to screws.
3. Install screws.
4. Connect electrical leads and remove tags. Then install gauge protective cover.
5. Close and secure instrument panel and instrument cover.

END OF TASK

END OF WORK PACKAGE

FIELD MAINTENANCE**2 kW MEP-501A/531A MILITARY TACTICAL GENERATOR SETS**
VOLTS METER: INSPECTION, TESTING, REMOVAL, INSTALLATION

INITIAL SETUP:**Tools and Special Tools**

Tool Kit, General Mechanic's Automotive or Standard Automotive Tool Set (WP 0159, Table 2, Item 6)
Multimeter (WP 0159, Table 2, Item 3)

Materials/Parts

Compound, Locking (WP 0162, Table 1, Item 7)

References

WP 0162, Table 1, Item 7

Equipment Condition

Generator set shut down (WP 0005, Stopping Procedure)
Cable disconnected for NATO Slave Receptacle (WP 0005)

WARNING

Never attempt to start the generator set if it is not properly grounded. Failure to observe this warning could result in serious injury or death by electrocution.

WARNING

High voltage is produced when this generator set is in operation. Use care when working around an open control panel with the generator set operating. Improper operation and/or failure to follow this warning could result in personal injury or death by electrocution.

INSPECTION

1. Shut down generator set.
2. Release instrument cover by turning fastener. Open instrument cover.
3. Release instrument panel by turning fastener. Open instrument panel slowly.
4. Inspect VOLTS meter for security, cracked lens, corrosion, and other damage.
5. Close and secure instrument panel and instrument cover.

END OF TASK**TESTING****Volts AC Meter**

1. Release instrument panel by turning fastener. Open instrument panel slowly.
2. Remove gauge protective cover.
3. Set multimeter for AC volts and connect to VOLTS AC meter terminals 1 and 2.

WARNING

High voltage is produced when this generator set is in operation. Use care when working around an open control panel with the generator set operating. Improper operation and/or failure to follow this warning could result in personal injury or death by electrocution.

4. Start and operate generator set at rated voltage. Record multimeter indication.

5. Shut down generator set.
6. Replace VOLTS AC meter if multimeter indicates AC voltage within rated range (114-126 VAC) and meter does not.
7. Install gauge protective cover.
8. Close and secure instrument panel.

END OF TASK**Volts DC Meter**

1. Release instrument panel by turning fastener. Open instrument panel slowly.
2. Remove gauge protective cover.
3. Set multimeter for DC volts and connect to VOLTS DC meter terminals.
4. Start and operate generator set at rated voltage (multimeter indication).
5. Shut down generator set.
6. Replace VOLTS DC meter if multimeter indicates DC voltage within rated range (26.6-32.2 VDC) and meter does not.
7. Install gauge protective cover.
8. Close and secure instrument panel.

END OF TASK**REMOVAL**

1. Shut down generator set.
2. Release instrument panel by turning fastener. Open instrument panel slowly.
3. Remove gauge protective cover. Then tag and disconnect VOLTS meter (Figure 1) electrical leads.
4. Release instrument cover by turning fastener. Open instrument cover.
5. Remove screws.
6. Remove VOLTS meter from instrument panel.

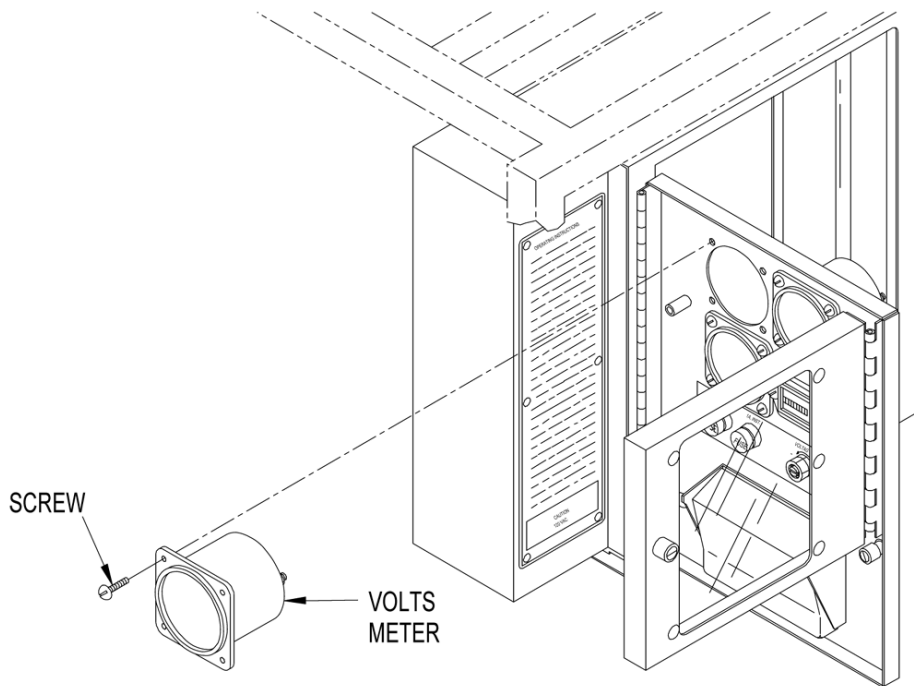

Figure 1. VOLTS Meter.

END OF TASK

INSTALLATION

1. Insert VOLTS meter (Figure 1) into instrument panel.
2. Apply locking compound (WP 0162, Table 1, Item 7) to screws.
3. Install screws.
4. Connect electrical leads and remove tags. Then install gauge protective cover.
5. Close and secure instrument panel and instrument cover.

END OF TASK

END OF WORK PACKAGE

FIELD MAINTENANCE**2 kW MEP-501A/531A MILITARY TACTICAL GENERATOR SETS****% LOAD METER: INSPECTION, TESTING, REMOVAL, INSTALLATION**

INITIAL SETUP:**Tools and Special Tools**

Tool Kit, General Mechanic's Automotive or Standard Automotive Tool Set (WP 0159, Table 2, Item 6)
Multimeter (WP 0159, Table 2, Item 3)

Materials/Parts

Compound, Locking (WP 0162, Table 1, Item 7)

References

WP 0162, Table 1, Item 7

Equipment Condition

Generator set shut down (WP 0005, Stopping Procedure)
Cable disconnected for NATO Slave Receptacle (WP 0005)

WARNING

Never attempt to start the generator set if it is not properly grounded. Failure to observe this warning could result in serious injury or death by electrocution.

WARNING

High voltage is produced when this generator set is in operation. Use care when working around an open control panel with the generator set operating. Improper operation and/or failure to follow this warning could result in personal injury or death by electrocution.

INSPECTION

1. Shut down generator set.
2. Release instrument cover by turning fastener. Open instrument cover.
3. Release instrument panel by turning fastener. Open instrument panel slowly.
4. Inspect % LOAD meter for security, cracked lens, corrosion, and other damage.
5. Close and secure instrument panel and instrument cover.

END OF TASK**TESTING****MEP-531A**

1. Shut down generator set.
2. Release instrument panel by turning fastener. Open instrument panel slowly.
3. Remove gauge protective cover.
4. Tag and disconnect wire M1⊗TB1-14 at % LOAD meter.
5. Set multimeter for amps and using alligator clips, connect multimeter between disconnected wire and terminal of % LOAD meter.

WARNING

High voltage is produced when this generator set is in operation. Use care when working around an open control panel with the generator set operating. Improper operation and/or failure to follow this warning could result in personal injury or death by electrocution.

6. Start and operate generator set at rated voltage and frequency. Apply some load to generator set.
7. Observe and note indications on multimeter and % LOAD meter. If no indication on multimeter, then fault is in wiring to % LOAD meter.
8. Shut down generator set.
9. Calculate percent of current from multimeter indication using following formula:

$$\text{Percent of Current} = 100 \times \frac{\text{Multimeter Indication}}{16.66}$$

10. Compare calculated percent of current to % LOAD meter indication noted during operation. If difference is greater than 10%, replace % LOAD meter.
11. Remove multimeter, connect wire M1 to TB1-14 to % LOAD meter.
12. Install gauge protective cover.
13. Close and secure instrument panel.

END OF TASK**MEP-501A**

1. Shut down generator set.
2. Release instrument panel by turning fastener. Open instrument panel slowly.
3. Remove gauge protective cover.
4. Tag and disconnect wire M1 (Red) at R3 at % LOAD meter.
5. Set multimeter for amps, and using alligator clips, connect multimeter between disconnected wire and terminal of % LOAD meter.

NOTE

If using a load greater than 10 amps, a shunt will be required.

6. Start and operate generator set at rated voltage and frequency. Apply some load to generator set.
7. Observe and note indications on multimeter and % LOAD meter. If no indication on multimeter, then fault is in wiring to % LOAD meter or in instrument shunt.
8. Shut down generator set.
9. Calculate percent of current from multimeter indication using following formula:

$$\text{Percent of Current} = 100 \times \frac{\text{Multimeter Indication}}{71.44}$$

10. Compare calculated percent of current to % LOAD meter indication noted during operation. If difference is greater than 10%, replace % LOAD meter.
11. Remove multimeter, connect wire M1 (Red) at R3 to % LOAD meter.
12. Install gauge protective cover.
13. Close and secure instrument panel.

END OF TASK

REMOVAL

1. Shut down generator set.
2. Release instrument panel by turning fastener. Open instrument panel slowly.
3. Remove gauge protective cover. Then tag and disconnect % LOAD meter (Figure 1) electrical leads.
4. Release instrument cover by turning fastener. Open instrument cover.
5. Remove screws.
6. Remove % LOAD meter from instrument panel.

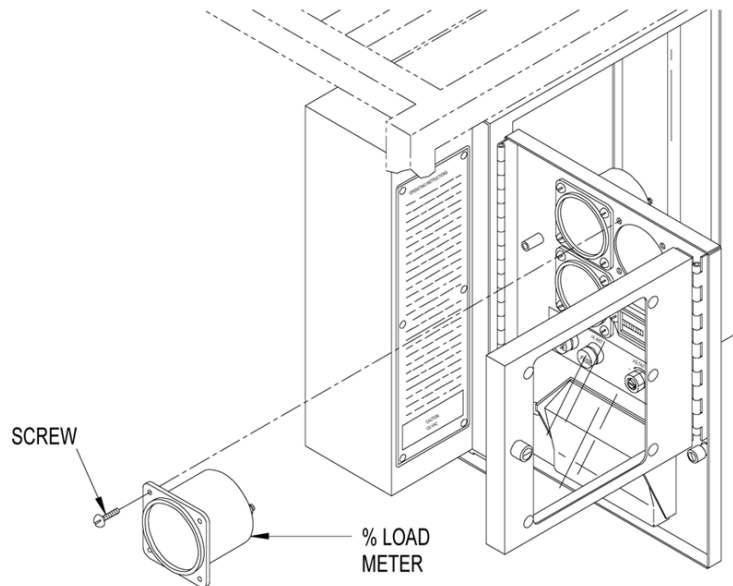
**Figure 1. % LOAD Meter.****END OF TASK****INSTALLATION**

1. Insert % LOAD meter (Figure 1) into instrument panel.
2. Apply locking compound (WP 0162, Table 1, Item 7) to screws.
3. Install screws.
4. Connect electrical leads and remove tags. Then install gauge protective cover.
5. Close and secure instrument panel and instrument cover.

END OF TASK**END OF WORK PACKAGE**

FIELD MAINTENANCE**2 kW MEP-501A/531A MILITARY TACTICAL GENERATOR SETS
HOURS METER: INSPECTION, TESTING, REMOVAL, INSTALLATION**

INITIAL SETUP:**Tools and Special Tools**

Tool Kit, General Mechanic's Automotive or
Standard Automotive Tool Set
(WP 0159, Table 2, Item 6)
Multimeter (WP 0159, Table 2, Item 3)

Materials/Parts

As required

Equipment Condition

Generator set shut down (WP 0005, Stopping
Procedure)
Cable disconnected for NATO Slave Receptacle
(WP 0005)

WARNING

Never attempt to start the generator set if it is not properly grounded. Failure to observe this warning could result in serious injury or death by electrocution.

WARNING

High voltage is produced when this generator set is in operation. Use care when working around an open control panel with the generator set operating. Improper operation and/or failure to follow this warning could result in personal injury or death by electrocution.

INSPECTION

1. Shut down generator set.
2. Release instrument cover by turning fastener. Open instrument cover.
3. Release instrument panel by turning fastener. Open instrument panel slowly.
4. Inspect HOURS meter for security, cracked lens, corrosion, and other damage.
5. Close and secure instrument panel and instrument cover.

END OF TASK**TESTING**

1. Release instrument panel by turning fastener. Open instrument panel slowly.
2. Set multimeter for DC volts and connect across terminals of HOURS meter.

WARNING

High voltage is produced when this generator set is in operation. Use care when working around an open control panel with the generator set operating. Improper operation and/or failure to follow this warning could result in personal injury or death by electrocution.

3. Start generator set and operate at rated voltage.
4. If 35-45 VDC is present, wait approximately six (6) minutes. HOURS meter should move 1/10 of an hour.
5. If HOURS meter does not operate properly, meter is defective and must be replaced.

6. Disconnect multimeter. Close and secure instrument panel.

END OF TASK

REMOVAL

1. Shut down generator set.
2. Release instrument panel by turning fastener. Open instrument panel slowly.
3. Tag and disconnect HOURS meter (Figure 1) electrical leads.
4. Release instrument cover by turning fastener. Open instrument cover.
5. Remove screws.
6. Remove HOURS meter from instrument panel.

END OF TASK

INSTALLATION

1. Insert HOURS meter (Figure 1) into instrument panel.
2. Install screws.
3. Connect electrical leads and remove tags.
4. Close and secure instrument panel and instrument cover.

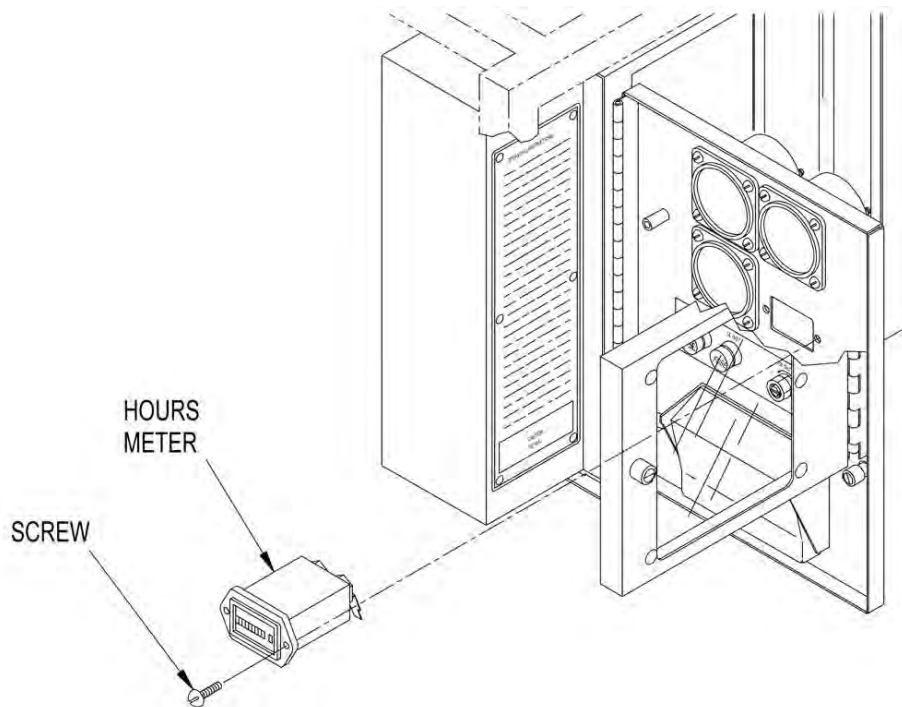

Figure 1. HOURS Meter.

END OF TASK

END OF WORK PACKAGE

FIELD MAINTENANCE**2 kW MEP-501A/531A MILITARY TACTICAL GENERATOR SETS
VOLTAGE ADJ. POTENTIOMETER: INSPECTION, TESTING, REMOVAL**

INITIAL SETUP:**Tools and Special Tools**

Tool Kit, General Mechanic's Automotive or Standard Automotive Tool Set (WP 0159, Table 2, Item 6)
Multimeter (WP 0159, Table 2, Item 3)

Materials/Parts

As required

References

WP 0099, Potentiometer, VOLTAGE ADJ.(P/N: 95-8077)
WP 0100, Potentiometer, VOLTAGE ADJ.(P/N: 95-8014)

Equipment Condition

Generator set shut down (WP 0005, Stopping Procedure)
Cable disconnected for NATO Slave Receptacle (WP 0005)

INSPECTION

1. Shut down generator set.
2. Release instrument cover by turning fastener. Open instrument cover.
3. Release instrument panel by turning fastener. Open instrument panel slowly.
4. Inspect VOLTAGE ADJ. potentiometer for security, loose connections, and other damage.
5. Close and secure instrument panel and instrument cover.

END OF TASK**TESTING**

1. Remove VOLTAGE ADJ. potentiometer, See Removal steps in this work package.
2. Set multimeter for ohms and connect across two outer terminals of VOLTAGE ADJ. potentiometer. Indication should be 900 to 1,000 ohms (MEP-531A) or 9,000 to 10,000 ohms (MEP-501A).
3. Rotate voltage adjust shaft counterclockwise as far as it will go.
4. Connect multimeter between center terminal and either outer terminal.
5. Slowly, at an even rate, rotate voltage adjust shaft clockwise as far as it will go while observing multimeter.
6. Multimeter indication shall increase, at an even rate, from 0 to 900-1,000 ohms (MEP-531A) or 0 to 9,000-10,000 ohms (MEP-501A).
7. Repeat Steps 3 through 6 for other outer terminal.
8. If multimeter indication changes erratically or indications are not as stated above when rotation is complete, VOLTAGE ADJ. potentiometer is defective and must be replaced.
9. If not defective, install VOLTAGE ADJ. potentiometer, see Installation instructions in this work package.

END OF TASK**REMOVAL**

1. Shut down generator set.
2. Release instrument panel by turning fastener. Open instrument panel slowly.
3. Tag and disconnect electrical leads for VOLTAGE ADJ. potentiometer (Figure 1) from terminals of TB1.

4. Release instrument cover by turning fastener. Open instrument cover.
5. Remove nuts, lockwasher and VOLTAGE ADJ. potentiometer from instrument panel.

END OF TASK

REPAIR

Repair VOLTAGE ADJ. potentiometer by assembling the potentiometer, wires, and terminals in accordance with WP 0099, Figure 1 (MEP-531A) or WP 0100, Figure 1 (MEP-501A).

INSTALLATION

1. Insert VOLTAGE ADJ. potentiometer (Figure 1) into instrument panel and secure with lockwasher and nuts.
2. Connect electrical leads to terminals of TB1 and remove tags.
3. Close and secure instrument panel and instrument cover.

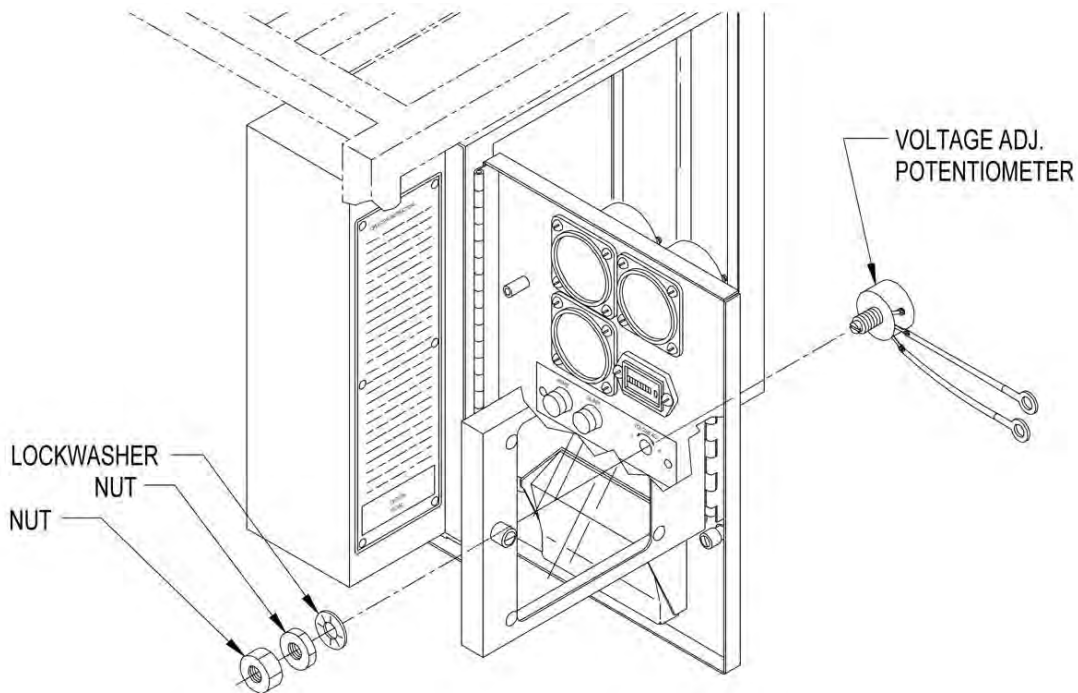

Figure 1. VOLTAGE ADJ. Potentiometer.

END OF TASK

END OF WORK PACKAGE

FIELD MAINTENANCE**2 kW MEP-501A/531A MILITARY TACTICAL GENERATOR SETS****INSTRUMENT SHUNT (MEP-501A): INSPECTION, REMOVAL, TESTING, INSTALLATION**

INITIAL SETUP:**Tools and Special Tools**

Tool Kit, General Mechanic's Automotive or
Standard Automotive Tool Set
(WP 0159, Table 2, Item 6)
Multimeter (WP 0159, Table 2, Item 3)

Materials/Parts

As required

Equipment Condition

Generator set shut down (WP 0005, Stopping
Procedure)
Cable disconnected for NATO Slave Receptacle
(WP 0005)

WARNING

Never attempt to start the generator set if it is not properly grounded. Failure to observe this warning could result in serious injury or death by electrocution.

WARNING

High voltage is produced when this generator set is in operation. Use care when working around an open control panel with the generator set operating. Improper operation and/or failure to follow this warning could result in personal injury or death by electrocution.

INSPECTION

1. Shut down generator set.
2. Release instrument panel by turning fastener. Open instrument panel slowly.
3. Inspect instrument shunt for security, corrosion, and loose wires.
4. Close and secure instrument panel.

END OF TASK**REMOVAL**

1. Shut down generator set.
2. Release instrument panel by turning fastener. Open instrument panel slowly.
3. Tag and disconnect electrical leads to instrument shunt (Figure 1).
4. Remove screws, lockwashers, and washers securing instrument shunt to control panel. Remove shunt resistor.

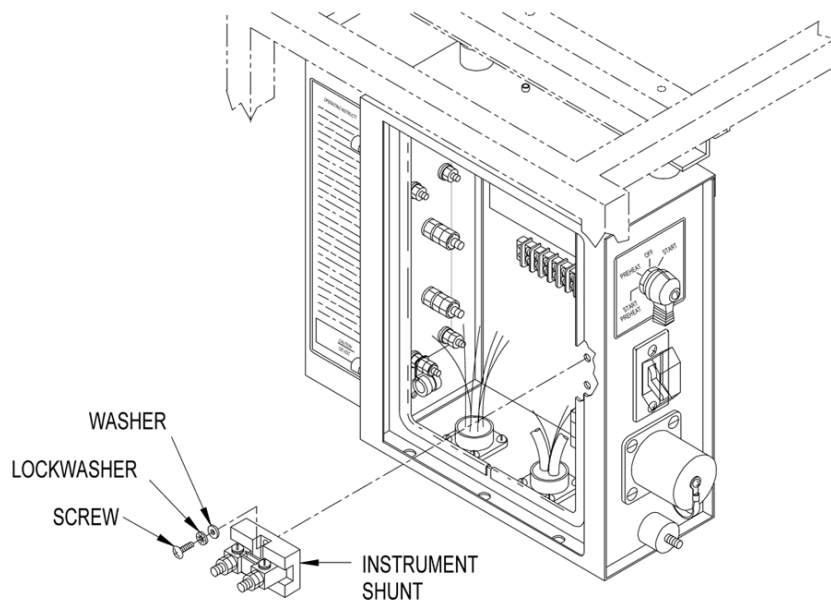

Figure 1. Instrument Shunt (MEP-501A).

END OF TASK

TESTING

1. Release instrument panel by turning fastener. Open instrument panel slowly.
2. Set multimeter for mVDC and connect to shunt terminals [M1-(RED) and M1-(BLK)].

WARNING

High voltage is produced when this generator set is in operation. Use care when working around an open control panel with the generator set operating. Improper operation and/or failure to follow this warning could result in personal injury or death by electrocution.

3. Start generator set connected to load bank and operate at rated voltage at no load.
4. Multimeter should indicate 0 mVDC.
5. Increase load to 50%. Multimeter should indicate 20 mVDC.
6. Increase load to 100%. Multimeter should indicate 40 mVDC.
7. Shutdown generator set.
8. Instrument shunt should be replaced if any of above multimeter readings are incorrect.
9. Close and secure instrument panel.

END OF TASK

INSTALLATION

1. Install instrument shunt (Figure 1) in control panel and secure with screws, lockwashers, and washers.
2. Connect wires to instrument shunt terminals as tagged. Remove tags.

3. Close and secure instrument panel.

END OF TASK

END OF WORK PACKAGE

FIELD MAINTENANCE**2 kW MEP-501A/531A MILITARY TACTICAL GENERATOR SETS****CAPACITOR (MEP-501A): INSPECTION, REMOVAL, TESTING, REPAIR, INSTALLATION**

INITIAL SETUP:**Tools and Special Tools**

Tool Kit, General Mechanic's Automotive or Standard Automotive Tool Set (WP 0159, Table 2, Item 6)
Multimeter (WP 0159, Table 2, Item 3)

Materials/Parts

As Required

References

WP 0102, Capacitor Assembly (P/N: 95-8017)

Equipment Condition

Generator set shut down (WP 0005, Stopping Procedure)
Cable disconnected for NATO Slave Receptacle (WP 0005)

WARNING

If 24 VDC battery source is connected to the North Atlantic Treaty Organization (NATO) slave receptacle, DC voltages are present at generator set electrical components even with generator set shut down. Avoid grounding self when touching any electrical components. Failure to observe this warning can result in personal injury.

INSPECTION

1. Shut down generator set.
2. Release instrument panel by turning fastener. Open instrument panel slowly.
3. Inspect capacitor for security, overheating, and other damage.
4. Close and secure instrument panel.

END OF TASK**REMOVAL**

1. Shut down generator set.
2. Release instrument panel by turning fastener. Open instrument panel slowly.
3. Cut tie down strap securing capacitor (Figure 1) to mount.
4. Tag and disconnect capacitor at terminal board and at load terminal (-). Remove capacitor from control panel.

END OF TASK**TESTING**

1. Shut down generator set.
2. Release instrument panel by turning fastener. Open instrument panel slowly.
3. Disconnect wire C1 (-) at load terminal (-) and wire C1 (+) at circuit breaker CB1.
4. Using multimeter, set for ohms, note resistance across terminals. Reverse leads and note resistance.
5. Resistance should be high in one direction and low in the other. If resistance is high or low in both directions, replace capacitor.

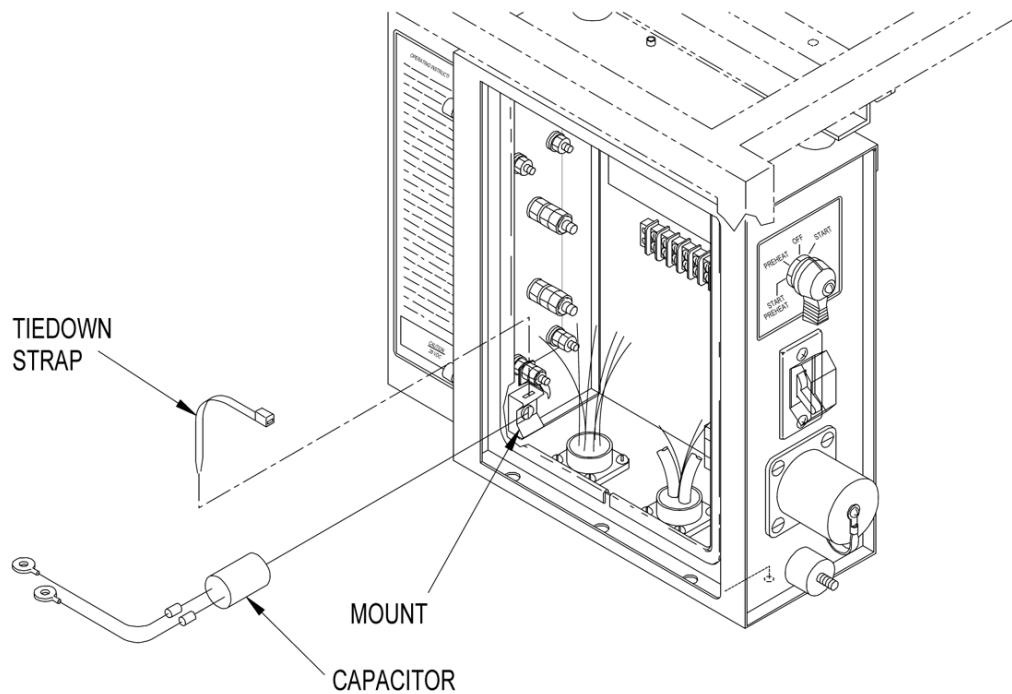

Figure 1. Capacitor (MEP-501A).

6. Reconnect wires.
7. Close and secure instrument panel.

END OF TASK

REPAIR

Repair capacitor by assembling the capacitor and terminals in accordance with WP 0102.

END OF TASK

INSTALLATION

1. Connect capacitor leads at terminal board and at load terminal (-) as tagged. Remove tags.
2. Secure capacitor (Figure 1) to mount with new tie down strap.
3. Close and secure instrument panel.

END OF TASK

END OF WORK PACKAGE

FIELD MAINTENANCE**2 kW MEP-501A/531A MILITARY TACTICAL GENERATOR SETS****TRANSIENT SUPPRESSOR ASSEMBLY (MEP-501A): INSPECTION, REMOVAL, TESTING, REPAIR,
INSTALLATION**

INITIAL SETUP:**Tools and Special Tools**

Tool Kit, General Mechanic's Automotive or
Standard Automotive Tool Set
(WP 0159, Table 2, Item 6)
Multimeter (WP 0159, Table 2, Item 3)

Materials/Parts

As required

References

WP 0112, Transient Suppressor (P/N: 95-8028)

Equipment Condition

Generator set shut down (WP 0005, Stopping
Procedure)
Cable disconnected for NATO Slave Receptacle
(WP 0005)

INSPECTION

1. Shut down generator set.
2. Release instrument panel by turning fastener. Open instrument panel slowly.
3. Inspect transient suppressor assembly for security and other damage.
4. Close and secure instrument panel.

END OF TASK**REMOVAL**

1. Shut down generator set.
2. Release instrument panel by turning fastener. Open instrument panel slowly.
3. Remove locknuts and washers (Figure 1) securing transient suppressor assembly to load terminals (+) and (-). Then remove transient suppressor assembly.

END OF TASK**TESTING**

1. Shut down generator set.
2. Release instrument panel by turning fastener. Open instrument panel slowly.
3. Disconnect transient suppressor assembly from positive load terminal.
4. Using multimeter, set for ohms, note resistance across terminals. Reverse leads and note resistance.
5. Resistance should be high in one direction and low in the other. If resistance is high or low in both directions, replace suppressor.
6. Reconnect transient suppressor assembly.
7. Close and secure instrument panel.

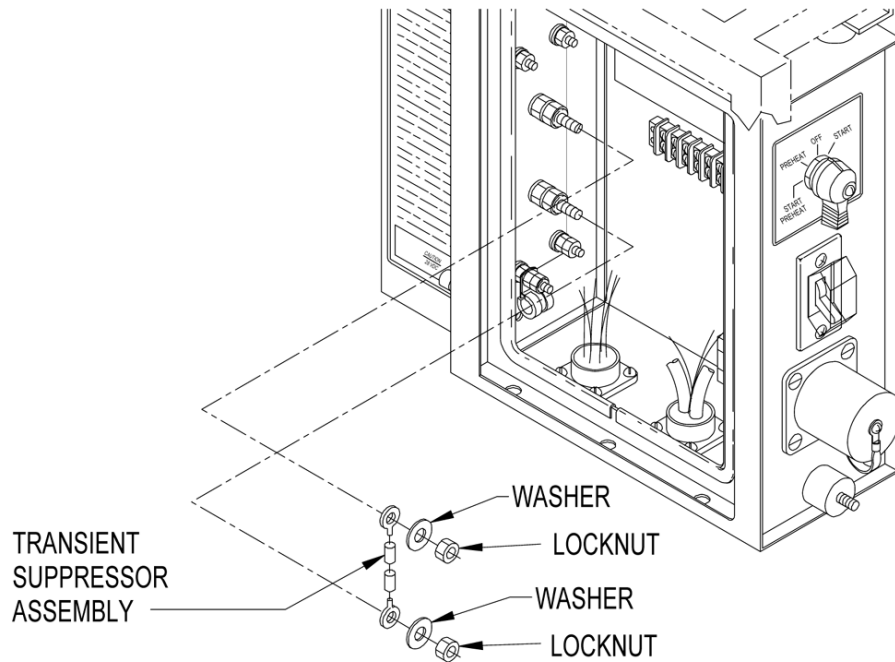

Figure 1. Transient Suppressor Assembly (MEP-501A).

END OF TASK

REPAIR

Repair transient suppressor assembly by assembling the transient suppressor assembly and terminals in accordance with WP 0112.

END OF TASK

INSTALLATION

1. Install transient suppressor assembly (Figure 1) on load terminals (+) and (-) with locknuts and washers.
2. Close and secure instrument panel.

END OF TASK

END OF WORK PACKAGE

FIELD MAINTENANCE**2 kW MEP-501A/531A MILITARY TACTICAL GENERATOR SETS****FUSEHOLDER(S): INSPECTION, REMOVAL, INSTALLATION**

INITIAL SETUP:**Tools and Special Tools**

Tool Kit, General Mechanic's Automotive or
Standard Automotive Tool Set
(WP 0159, Table 2, Item 6)

Materials/Parts

As required

Equipment Condition

Generator set shut down (WP 0005, Stopping
Procedure)
Cable disconnected for NATO Slave Receptacle
(WP 0005)

INSPECTION

1. Shut down generator set.
2. Release instrument cover by turning fastener. Open instrument cover.
3. Release instrument panel by turning fastener. Open instrument panel slowly.
4. Inspect fuse holder for security, cracked cap, corrosion, and other damage.
5. Inspect fuse for cracks and burned out element.
6. Close and secure instrument panel and instrument cover.

END OF TASK**REMOVAL**

1. Shut down generator set.
2. Release instrument panel by turning fastener. Open instrument panel slowly.
3. Tag and disconnect electrical leads from fuseholder (Figure 1).
4. Release instrument cover by turning fastener. Open instrument cover.
5. Remove nut.
6. Remove fuse holder, complete with fuse.
7. If necessary, remove cap and fuse.

END OF TASK**INSTALLATION**

1. If removed, insert fuse (Figure 1) into fuse holder and install cap.
2. Position fuse holder in instrument panel.
3. Install nut.
4. Connect electrical leads and remove tags.
5. Close and secure instrument panel and instrument cover.

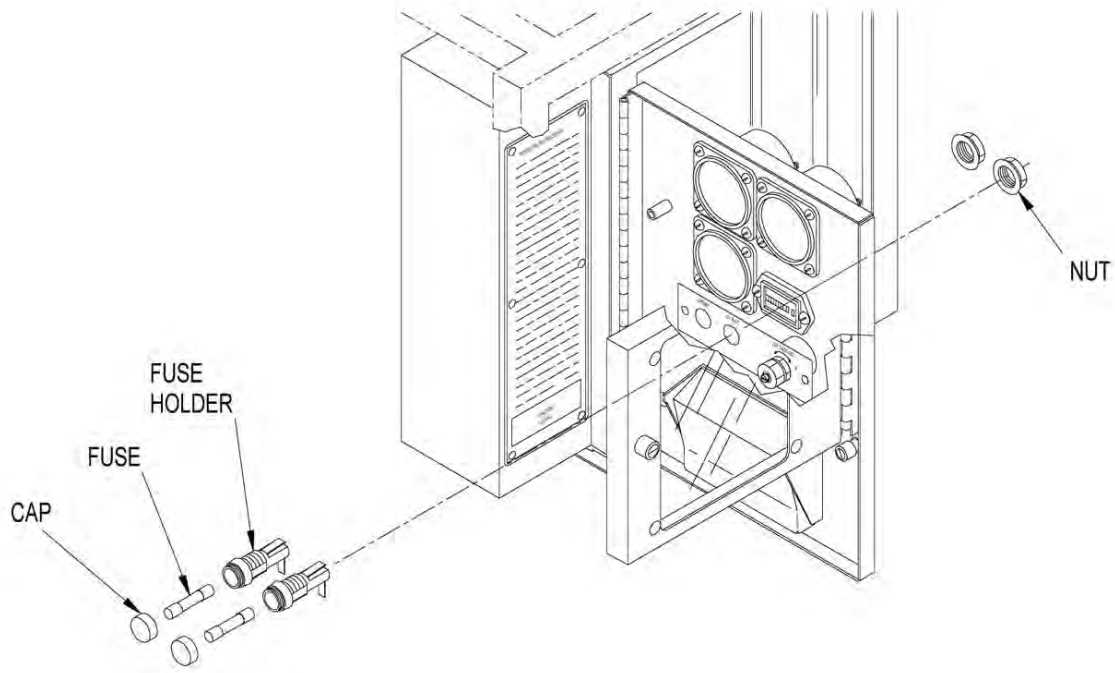

Figure 1. Fuseholder(s).

END OF TASK

END OF WORK PACKAGE

FIELD MAINTENANCE**2 kW MEP-501A/531A MILITARY TACTICAL GENERATOR SETS
GROUND STRAP(S): INSPECTION, REMOVAL, INSTALLATION**

INITIAL SETUP:**Tools and Special Tools**

Tool Kit, General Mechanic's Automotive or Standard Automotive Tool Set (WP 0159, Table 2, Item 6)
Shop Equipment, Automotive Maintenance and Repair, Field Maintenance, Suppl 1 W/O Power (WP 0159, Table 2, Item 4)

Materials/Parts

As required

Equipment Condition

Generator set shut down (WP 0005, Stopping Procedure)
Cable disconnected for NATO Slave Receptacle (WP 0005)

INSPECTION

1. Inspect braided strap for broken strands, corrosion, and damage.
2. Inspect connectors for damage and corrosion.

END OF TASK**REMOVAL**

1. Remove nuts, lockwashers, washers, and capscrews as applicable securing ground strap (Figure 1) at both ends.
2. Remove ground strap.

END OF TASK**INSTALLATION**

1. Position ground strap (Figure 1).
2. Secure ground strap at both ends with nuts, lockwashers, washers, and capscrews as applicable. Torque nut to 75 lb-in. (8.5 N•m).

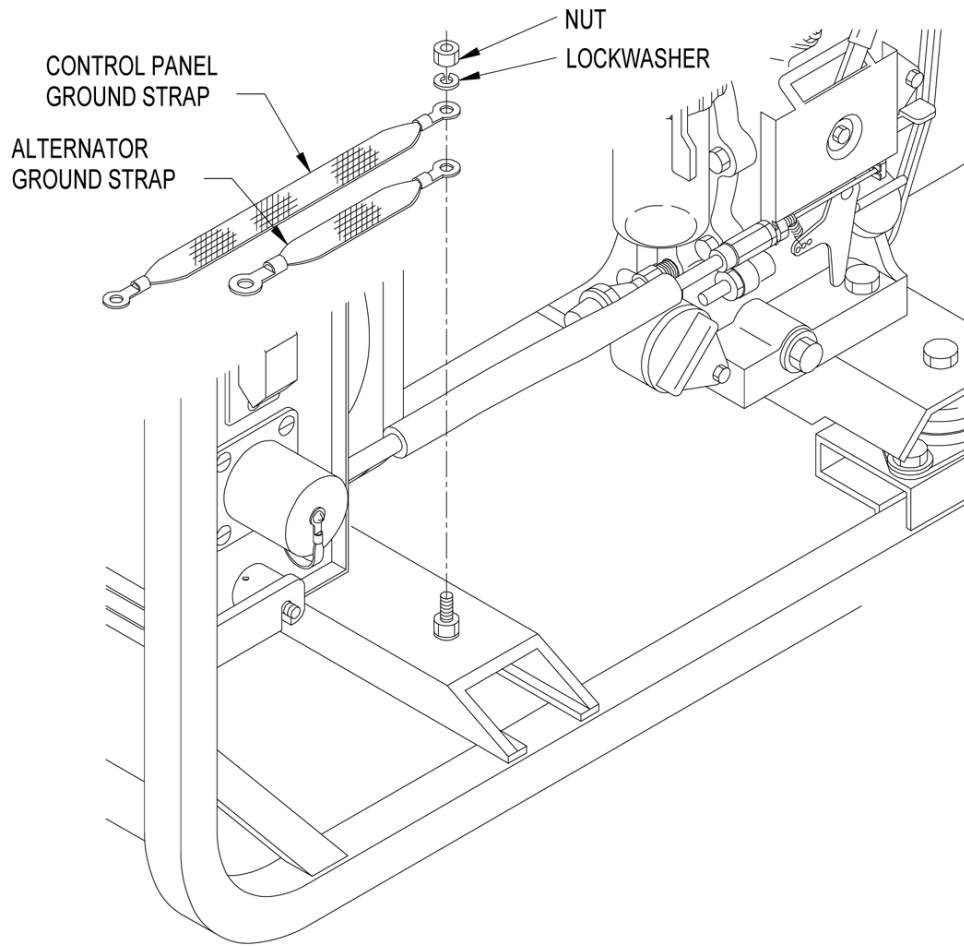

Figure 1. Ground Strap(s).

END OF TASK

END OF WORK PACKAGE

FIELD MAINTENANCE**2 kW MEP-501A/531A MILITARY TACTICAL GENERATOR SETS****GFCI RECEPTACLE AND RECEPTACLE COVER (MEP-531A): INSPECTION, TESTING, REMOVAL,
INSTALLATION**

INITIAL SETUP:**Tools and Special Tools**

Tool Kit, General Mechanic's Automotive or
Standard Automotive Tool Set
(WP 0159, Table 2, Item 6)
Multimeter (WP 0159, Table 2, Item 3)

Materials/Parts

As required

Equipment Condition

Generator set shut down (WP 0005, Stopping
Procedure)
Cable disconnected for NATO Slave Receptacle
(WP 0005)

INSPECTION

1. Shut down generator set.
2. Release instrument panel by turning fastener. Open instrument panel slowly.
3. Inspect GFCI receptacle for security, cracks, corrosion, and other damage.
4. Close and secure instrument panel.

END OF TASK**TESTING**

1. Shut down generator set.
2. Release instrument panel by turning fastener. Open instrument panel slowly.
3. Tag and disconnect GFCI receptacle (Figure 1) electrical leads.
4. Set multimeter for ohms and check for continuity between side terminals of each plug outlet.
5. Replace GFCI receptacle if continuity is indicated between terminals.
6. Connect electrical leads to receptacle and remove tags.
7. Close and secure instrument panel.

END OF TASK**REMOVAL**

1. Shut down generator set.
2. Release instrument panel by turning fastener. Open instrument panel slowly.
3. Tag and disconnect GFCI receptacle (Figure 1) electrical leads.
4. Remove nuts, lockwashers, screws, washers, and cover.
5. Remove GFCI receptacle from instrument panel.

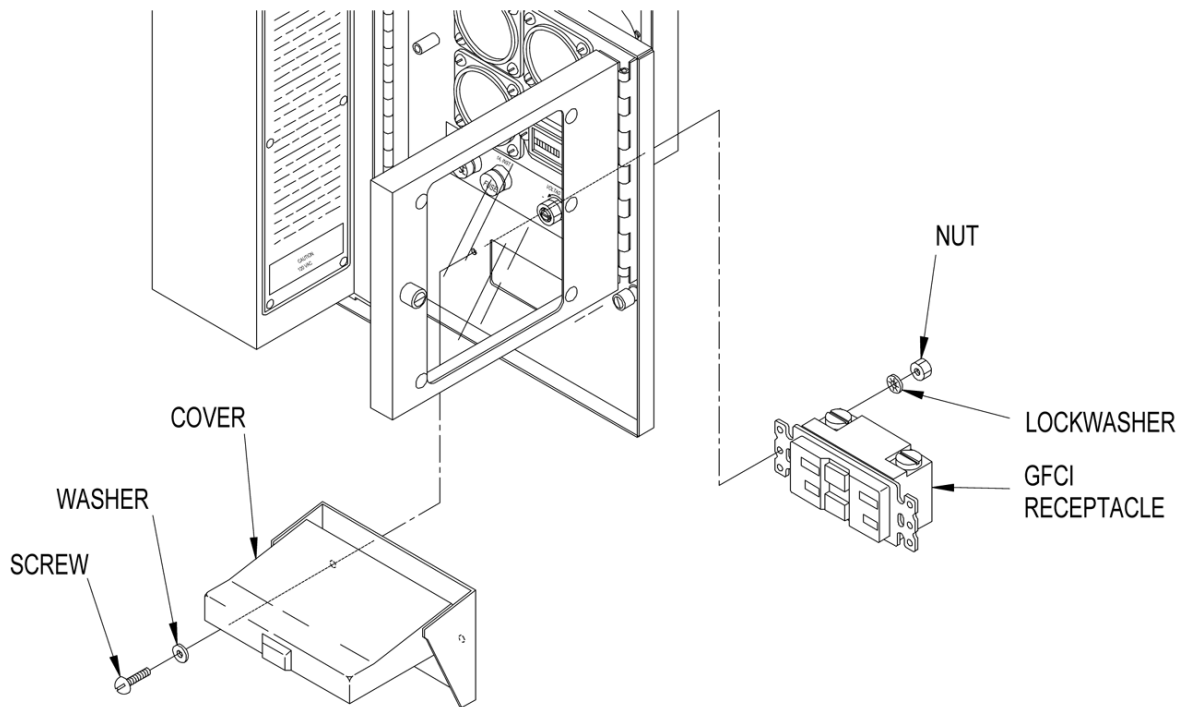

Figure 1. GFCI Receptacle and Receptacle Cover (MEP-531A).

END OF TASK

INSTALLATION

1. Insert GFCI receptacle (Figure 1) into instrument panel.
2. Position cover over GFCI receptacle and secure both with washers, screws, lockwashers, and nuts.
3. Connect electrical leads and remove tags.
4. Close and secure instrument panel.

END OF TASK

END OF WORK PACKAGE

FIELD MAINTENANCE**2 kW MEP-501A/531A MILITARY TACTICAL GENERATOR SETS****START-PREHEAT/PREHEAT/OFF/START ROTARY SWITCH: INSPECTION, TESTING, REMOVAL,
INSTALLATION**

INITIAL SETUP:**Tools and Special Tools**

Tool Kit, General Mechanic's Automotive or
Standard Automotive Tool Set
(WP 0159, Table 2, Item 6)
Multimeter (WP 0159, Table 2, Item 3)

Materials/Parts

As required

Equipment Condition

Generator set shut down (WP 0005, Stopping
Procedure)
Cable disconnected for NATO Slave Receptacle
(WP 0005)

INSPECTION

1. Shut down generator set.
2. Release instrument panel by turning fastener. Open instrument panel slowly.
3. Inspect START-PREHEAT/PREHEAT/OFF/START rotary switch for security, cracks, corrosion, and other damage.
4. Close and secure instrument panel.

END OF TASK**TESTING**

1. Shut down generator set.
2. If connected, disconnect power source at NATO slave receptacle.
3. Release instrument panel by turning fastener. Open instrument panel slowly.
4. Tag and disconnect START-PREHEAT/PREHEAT/OFF/START rotary switch (Figure 1) electrical leads and check switch for continuity using multimeter. Refer to Electrical Schematic Figure FO-1 (MEP-531A) or Figure FO-2 (MEP-501A) to determine circuits made to corresponding switch positions.
5. Check continuity until all four positions have been checked.
6. If readings are not as noted in schematic, switch is unserviceable and must be replaced.
7. Connect electrical leads, remove tags, close and secure instrument panel.

END OF TASK**REMOVAL**

1. Shut down generator set.
2. Release instrument panel by turning fastener. Open control panel slowly.
3. Tag and disconnect START-PREHEAT/PREHEAT/OFF/START rotary switch (Figure 1) electrical leads.
4. Remove screw and knob from START-PREHEAT/PREHEAT/OFF/START rotary switch.

5. Remove nut, instruction plate, and START-PREHEAT/PREHEAT/OFF/START rotary switch from control panel.

END OF TASK

INSTALLATION

1. Insert START-PREHEAT/PREHEAT/OFF/START rotary switch (Figure 1) into control panel.
2. Position instruction plate over START-PREHEAT/PREHEAT/OFF/START rotary switch and secure both in control panel with nut.
3. Install screw and knob on START-PREHEAT/PREHEAT/OFF/START rotary switch.
4. Connect electrical leads and remove tags.
5. Close and secure instrument panel.

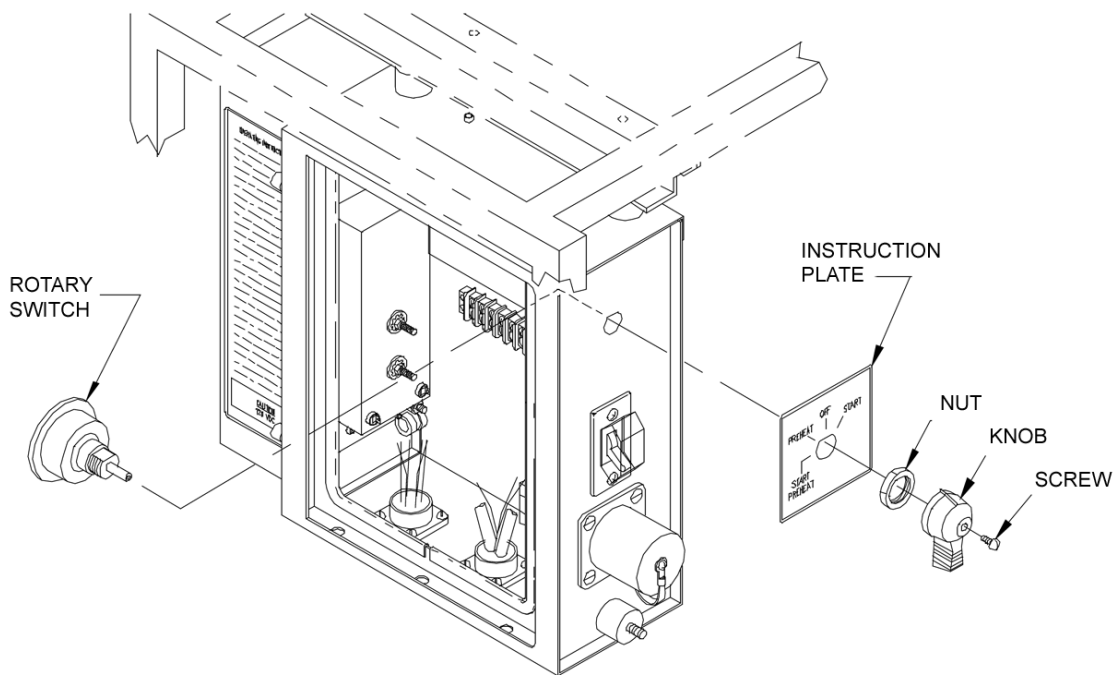

Figure 1. START-PREHEAT/PREHEAT/OFF/START Rotary Switch.

END OF TASK

END OF WORK PACKAGE

FIELD MAINTENANCE**2 kW MEP-501A/531A MILITARY TACTICAL GENERATOR SETS
DISCHARGE VARISTOR: INSPECTION, TESTING, REMOVAL, INSTALLATION**

INITIAL SETUP:**Tools and Special Tools**

Tool Kit, General Mechanic's Automotive or
Standard Automotive Tool Set
(WP 0159, Table 2, Item 6)
Multimeter (WP 0159, Table 2, Item 3)

Materials/Parts

As required

Equipment Condition

Generator set shut down (WP 0005, Stopping
Procedure)
Cable disconnected for NATO Slave Receptacle
(WP 0005)

INSPECTION

1. Shut down generator set.
2. Release instrument panel by turning fastener. Open instrument panel slowly.
3. Visually inspect the discharge varistor for security, cracks, broken wires, corrosion, and other damage.
4. Close and secure instrument panel.

END OF TASK**TESTING**

1. Disconnect one lead from discharge varistor (Figure 1).
2. Set multimeter for ohms and check across leads for continuity in both directions.
3. Replace discharge varistor if continuity is indicated in either direction.
4. Install disconnected lead of discharge varistor.

END OF TASK**REMOVAL**

1. Shut down generator set.
2. Release instrument panel by turning fastener. Open instrument panel slowly.
3. Tag electrical leads for discharge varistor (Figure 1) at terminals 5 and 6 of TB1 (MEP-531A) or terminals 6 and 7 of TB1 (MEP-501A).
4. Remove screws and discharge varistor from control panel.

END OF TASK**INSTALLATION**

1. Install discharge varistor (Figure 1) in control panel with screws.
2. Remove tags from electrical leads.
3. Close and secure instrument panel.

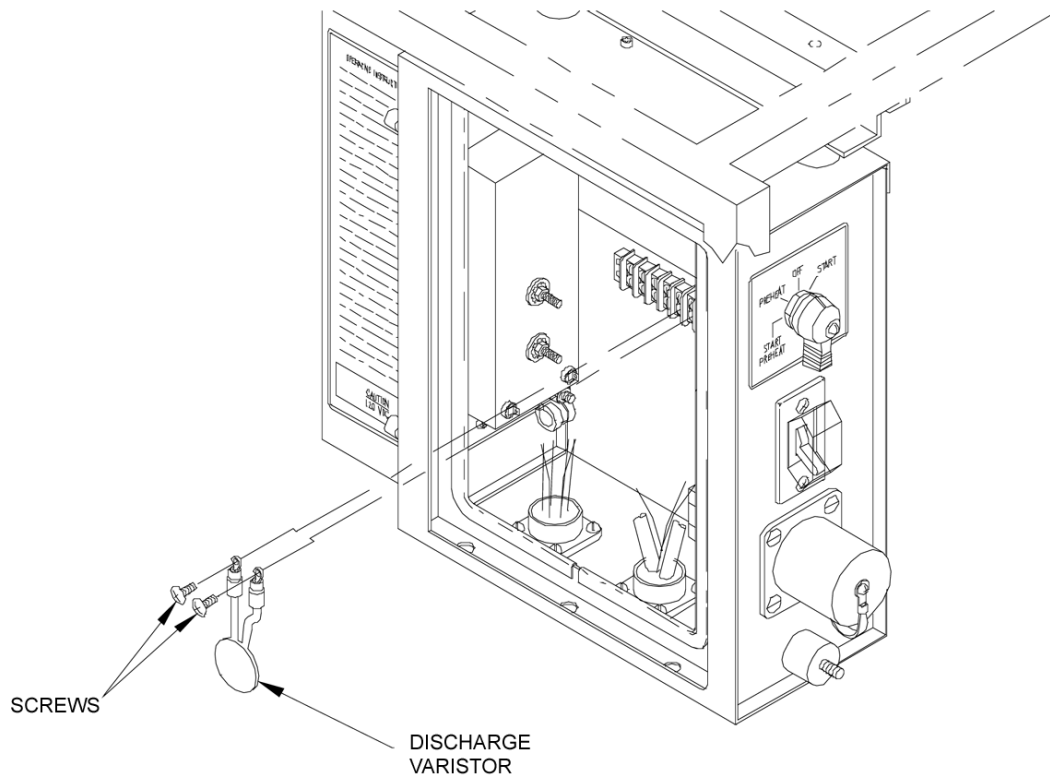

Figure 1. Discharge Varistor.

END OF TASK

END OF WORK PACKAGE

FIELD MAINTENANCE**2 kW MEP-501A/531A MILITARY TACTICAL GENERATOR SETS
NATO SLAVE RECEPTACLE: INSPECTION, REMOVAL, INSTALLATION**

INITIAL SETUP:**Tools and Special Tools**

Tool Kit, General Mechanic's Automotive or
Standard Automotive Tool Set
(WP 0159, Table 2, Item 6)

Materials/Parts

As required

Equipment Condition

Generator set shut down (WP 0005, Stopping
Procedure)
Cable disconnected for NATO Slave Receptacle
(WP 0005)

INSPECTION

1. Shut down generator set.
2. Release instrument panel by turning fastener. Open instrument panel slowly.
3. Inspect NATO slave receptacle for security, corrosion, and other damage.
4. Close and secure instrument panel.

END OF TASK**REMOVAL**

1. Shut down generator set.
2. Release instrument panel by turning fastener. Open instrument panel slowly.
3. Tag and disconnect electrical leads from NATO slave receptacle (Figure 1).
4. Remove nuts, lockwashers, washers, screws, cover, bracket, and NATO slave receptacle with gasket from control panel.

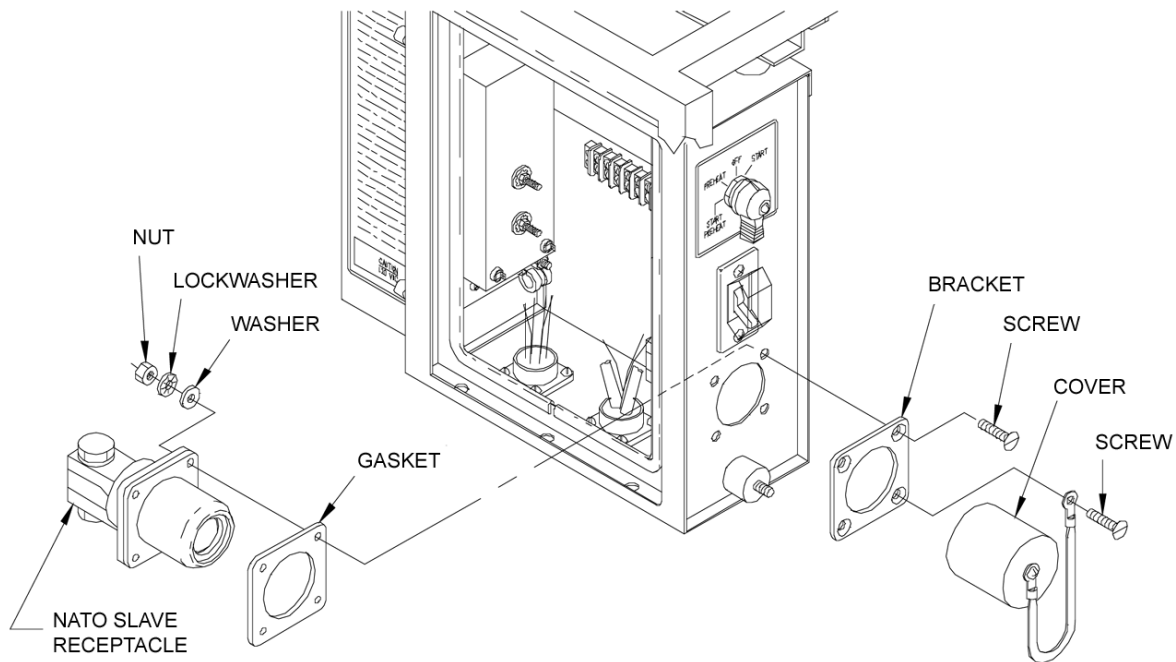

Figure 1. NATO Slave Receptacle.

END OF TASK

INSTALLATION

1. Insert NATO slave receptacle (Figure 1) with gasket into control panel.
2. Position bracket and cover on NATO slave receptacle.
3. Secure NATO slave receptacle, bracket, and cover to control panel with screws, washers, lockwashers, and nuts.
4. Connect electrical leads to NATO slave receptacle and remove tags.
5. Close and secure instrument panel.

END OF TASK

END OF WORK PACKAGE

FIELD MAINTENANCE**2 kW MEP-501A/531A MILITARY TACTICAL GENERATOR SETS****LOAD TERMINAL(S) (MEP-501A AND MECHRON SETS): INSPECTION, REMOVAL, INSTALLATION**

INITIAL SETUP:**Tools and Special Tools**

Tool Kit, General Mechanic's Automotive or
Standard Automotive Tool Set
(WP 0159, Table 2, Item 6)

Materials/Parts

As required

Equipment Condition

Generator set shut down (WP 0005, Stopping
Procedure)
Cable disconnected for NATO Slave Receptacle
(WP 0005)

WARNING

Be sure the load terminal retaining clip is closed to prevent contact with the lug cover as electrical shock could occur.

WARNING

Note the orientation of the load terminals before removing them. They must be installed in exactly the same way to preclude the possibility of accidental contact with the lug cover and the potential for electrical shock resulting from this contact.

INSPECTION

1. Shut down generator set.
2. Release instrument panel by turning fastener. Open instrument panel slowly.
3. Release lug cover by turning two fasteners. Open lug cover.
4. Inspect the load terminals for deformed threads, corrosion, or other physical damage.
5. Ensure that the connections to the load terminals are clean and tight. Replace if defective.
6. Close and secure instrument panel.
7. Close and secure lug cover.

END OF TASK**REMOVAL**

1. Shut down generator set.
2. Release lug cover by turning two fasteners. Open lug cover.
3. Disconnect load cables from load terminals (Figure 1) as necessary.
4. Release instrument panel by turning fastener. Open instrument panel slowly.
5. Remove locknuts, washers, transient suppressor assembly, and nuts from load terminals.
6. Tag and remove electrical leads from load terminals.

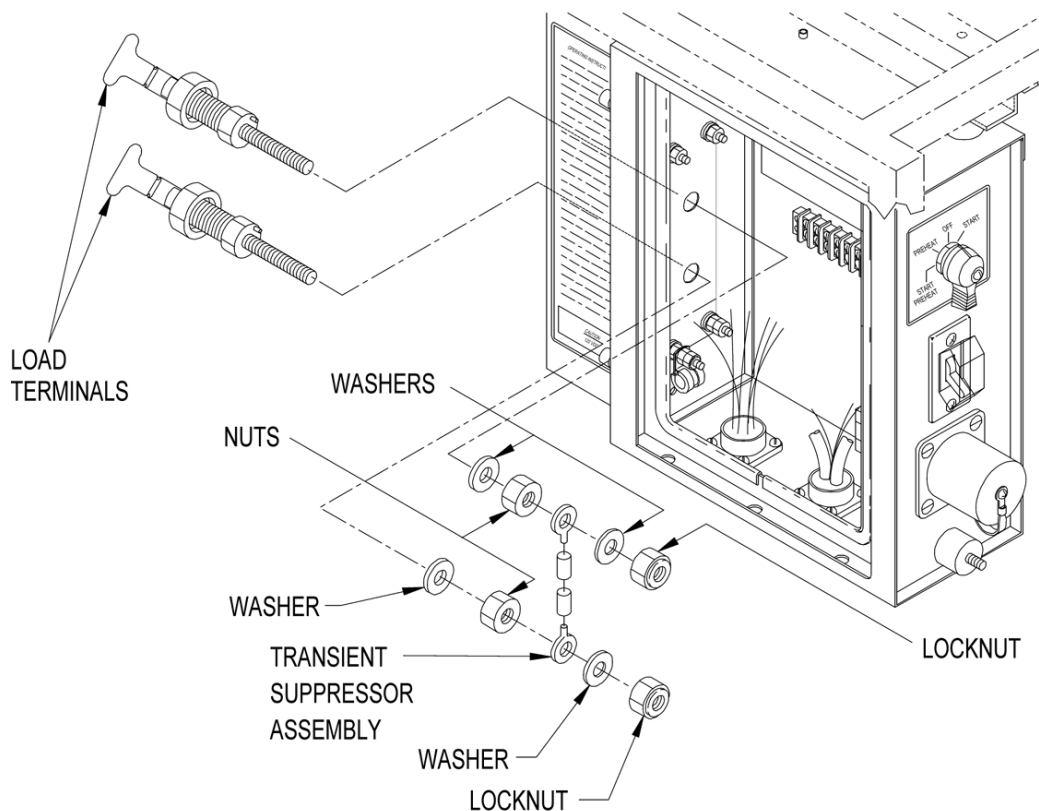

Figure 1. Load Terminal(s) (MEP-501A and Mechron Sets).

WARNING

Note the orientation of the load terminals before removing them. They must be installed in exactly the same way to preclude the possibility of accidental contact with the lug cover and the potential for electrical shock resulting from this contact.

7. Hold terminal body hex with wrench and remove nuts, washers, and load terminals from load terminal board.

END OF TASK

INSTALLATION

WARNING

Be sure the load terminal retaining clip is closed to prevent contact with the lug cover as electrical shock could occur.

1. Install load terminals (Figure 1) in load terminal board. Then hold terminal body hex with wrench and install washers and nuts.
2. Position transient suppressor assembly and electrical leads on load terminals and secure with washers, nuts, and locknuts. Remove tags.
3. Close and secure instrument panel.
4. Connect load cables to load terminals as necessary.

5. Close and secure lug cover.

END OF TASK

END OF WORK PACKAGE

FIELD MAINTENANCE**2 kW MEP-501A/531A MILITARY TACTICAL GENERATOR SETS****TERMINAL BOARD: INSPECTION, REMOVAL, TESTING, INSTALLATION**

INITIAL SETUP:**Tools and Special Tools**

Tool Kit, General Mechanic's Automotive or Standard Automotive Tool Set (WP 0159, Table 2, Item 6)
Multimeter (WP 0159, Table 2, Item 3)

Materials/Parts

As required

References

WP 0048, Discharge varistor

Equipment Condition

Generator set shut down (WP 0005, Stopping Procedure)
Cable disconnected for NATO Slave Receptacle (WP 0005)

INSPECTION**NOTE**

Terminal board numbering runs from left to right starting with number 1.

1. Shut down generator set.
2. Release instrument panel by turning fastener. Open instrument panel slowly.
3. Visually inspect terminal board for security, cracks, broken jumpers, corrosion, and other damage.
4. Close and secure instrument panel.

END OF TASK**REMOVAL**

1. Shut down generator set.
2. Release instrument panel by turning fastener. Open instrument panel slowly.
3. If replacing terminal board remove and retain discharge varistor, refer to WP 0048, Removal.
4. Tag and disconnect electrical leads from terminal board (Figure 1).
5. Tag and remove bus (MEP-531A) from terminal board.
6. Remove screws, lockwashers, washers, and terminal board from control panel.

END OF TASK**TESTING**

1. Remove terminal board. Refer to Removal.
2. Using multimeter set for ohms, check for continuity across each set of terminals. Replace terminal board if any terminal sets indicate an open circuit.
3. Install terminal board. Refer to Installation.

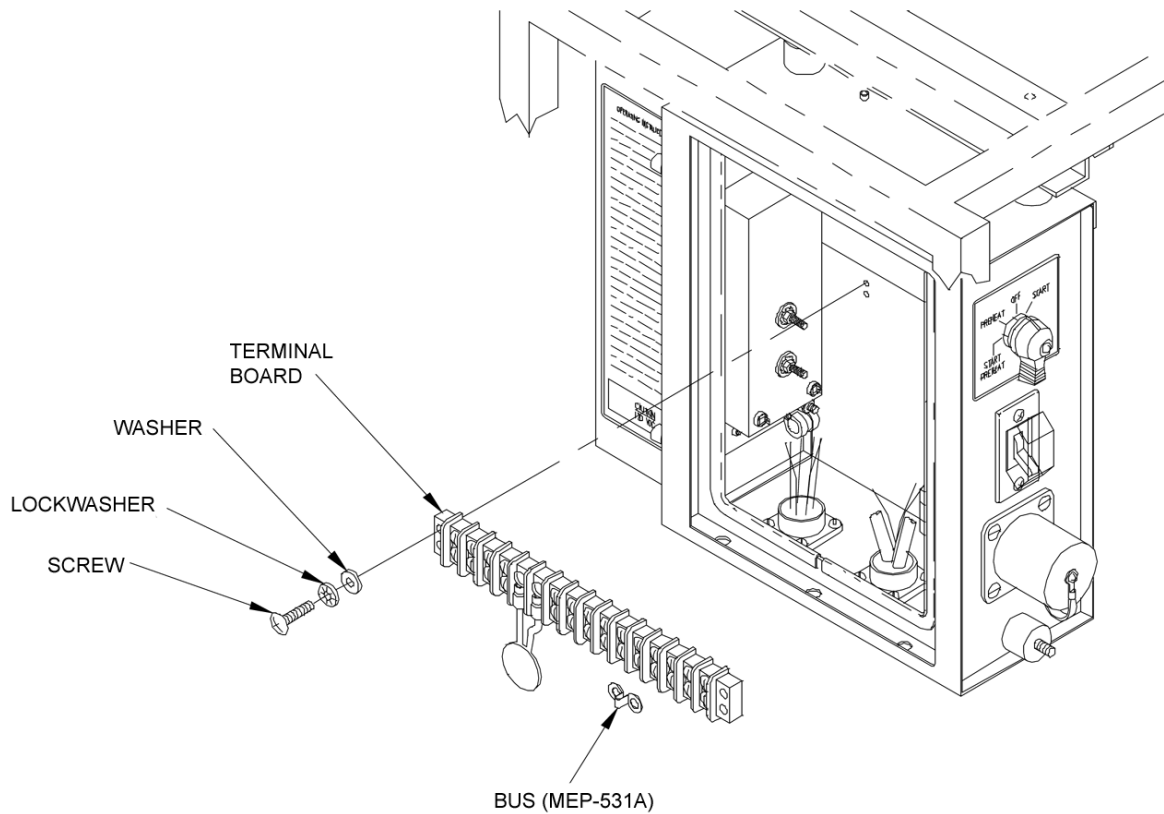

Figure 1. Terminal Board.

END OF TASK

INSTALLATION

1. Install terminal board (Figure 1) in control panel with washers, lockwashers, and screws.
2. Connect bus (MEP-531A) and electrical leads to terminal board. Remove tags.
3. If removed, install discharge varistor. Refer to WP 0048, Installation.
4. Close and secure instrument panel.

END OF TASK

END OF WORK PACKAGE

FIELD MAINTENANCE**2 kW MEP-501A/531A MILITARY TACTICAL GENERATOR SETS****LOAD TERMINAL BOARD (MEP-501A AND MECHRON SETS): INSPECTION, REMOVAL, INSTALLATION**

INITIAL SETUP:**Tools and Special Tools**

Tool Kit, General Mechanic's Automotive or Standard Automotive Tool Set
(WP 0159, Table 2, Item 6)

Materials/Parts

As required

References

WP 0050, Load Terminal(s)(MEP-501A and Mechron Sets)

Equipment Condition

Generator set shut down (WP 0005, Stopping Procedure)
Cable disconnected for NATO Slave Receptacle (WP 0005)

INSPECTION

1. Shut down generator set.
2. Release instrument panel by turning fastener. Open instrument panel slowly.
3. Release lug cover by turning two fasteners. Open lug cover.
4. Inspect load terminal board for security, cracks, deterioration, or other physical damage. Replace if defective.
5. Close and secure instrument panel.
6. Close and secure lug cover.

END OF TASK**REMOVAL**

1. Shut down generator set.
2. Remove load terminals, refer to WP 0050, Removal.
3. Remove nut (Figure 1, Item 5), lockwashers (6), washers (7) and electrical wiring with p-clamp (3) from screw (8).
4. Remove locknut (2), washers (7), lockwasher (6), ground strap (4), and nut (5) from screw (9).
5. Remove nuts (5), lockwashers (6), washers (7), screws (10), and load terminal board (1) from control panel.

END OF TASK**INSTALLATION**

1. Install load terminal board (Figure 1, Item 1) on control panel with screws (10), washers (7), lockwashers (6), and nuts (5).
2. Install washers (7), lockwasher (6), nut (5), ground strap (4) and locknut (2) on screw (9).
3. Install washers (7), lockwashers (6), nuts (5), and electrical wiring with p-clamp (3) on screw (8).
4. Install load terminals, refer to WP 0050, Installation.

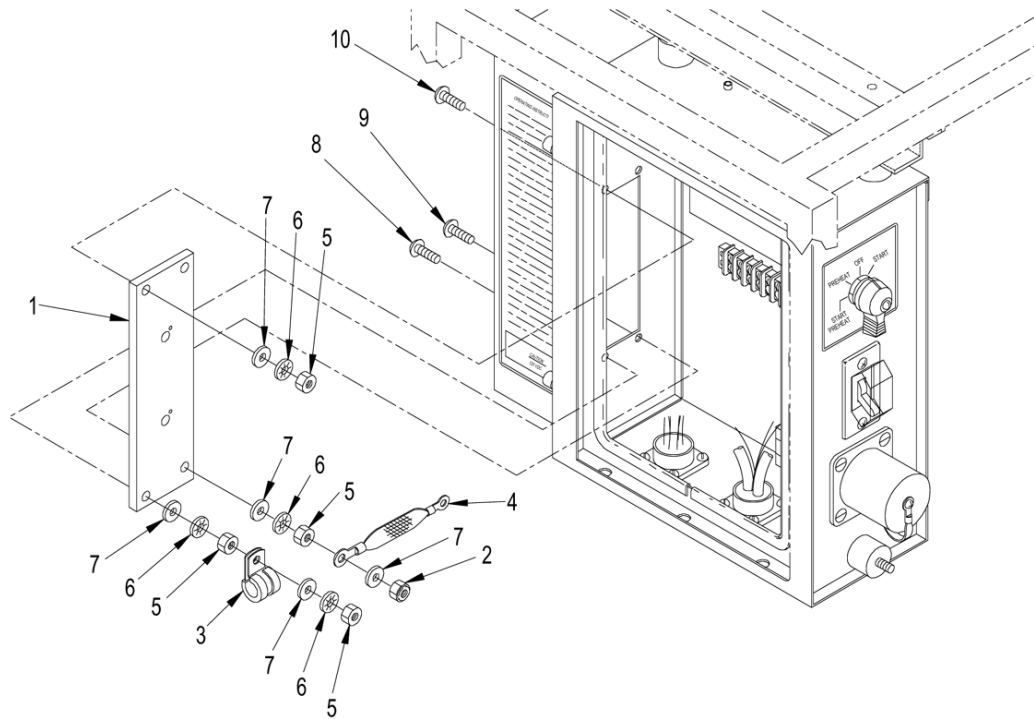

LEGEND

- 1 Load Terminal Board
- 2 Locknut
- 3 P. Clamp
- 4 Ground Strap
- 5 Nut
- 6 Lockwasher
- 7 Washer
- 8 Screw
- 9 Screw
- 10 Screw

Figure 1. Load Terminal Board (MEP-501A and Mechron Sets).

END OF TASK

END OF WORK PACKAGE

FIELD MAINTENANCE**2 kW MEP-501A/531A MILITARY TACTICAL GENERATOR SETS
ON-OFF LOAD CIRCUIT BREAKER ASSEMBLY AND BOOT: INSPECTION, TESTING, REMOVAL,
INSTALLATION**

INITIAL SETUP:**Tools and Special Tools**

Tool Kit, General Mechanic's Automotive or
Standard Automotive Tool Set
(WP 0159, Table 2, Item 6)
Multimeter (WP 0159, Table 2, Item 3)

Materials/Parts

As required

Equipment Condition

Generator set shut down (WP 0005, Stopping
Procedure)
Cable disconnected for NATO Slave Receptacle
(WP 0005)

INSPECTION

1. Shut down generator set.
2. Release instrument panel by turning fastener. Open instrument panel slowly.
3. Inspect ON-OFF load circuit breaker assembly for security, cracks, corrosion, and other damage.
4. Close and secure instrument panel.

END OF TASK**TESTING MEP-531A**

1. Shut down generator set.
2. Release instrument panel by turning fastener. Open instrument panel slowly.

NOTE

Refer to Wiring Diagram Figure FO-3 for terminal positions.

3. Check for open circuits between terminals COM and NO, and terminals A and B.
4. Place and hold ON-OFF load circuit breaker assembly in ON position.
5. Check for continuity between terminals COM and NO, and terminals A and B.
6. Remove shrink wrap and check diode assembly CR2 as follows:
 - a. Using multimeter, set for ohms, note resistance across terminals. Reverse leads and note resistance.
 - b. Resistance should be high in one direction and low in the other. If resistance is high or low in both directions, replace entire ON-OFF load circuit breaker assembly.
7. Remove and replace entire assembly if any continuity/resistance check is other than indicated above.
8. Close and secure instrument panel.

END OF TASK

TESTING MEP-501A

1. Shut down generator set.
2. Release instrument panel by turning fastener. Open instrument panel slowly.

NOTE

Refer to Wiring Diagram Figure FO-4 for terminal positions.

3. Set multimeter to ohms and with ON-OFF load circuit breaker assembly in ON position, check for continuity between terminals P1 and P2.
4. Check for open circuit between terminals P1 and P2 with load circuit breaker in OFF position.
5. Repeat Steps 3 and 4 for other half of ON-OFF load circuit breaker.
6. Remove and replace entire ON-OFF load circuit breaker if any reading is other than indicated above.
7. Close and secure instrument panel.

END OF TASK**REMOVAL**

1. Shut down generator set.
2. Release instrument panel by turning fastener, open instrument panel slowly.
3. Tag and disconnect electrical leads for ON-OFF load circuit breaker assembly (Figure 1) from TB1-2 and TB1-7 (MEP-531A).
4. Tag and disconnect electrical leads from terminals on ON-OFF load circuit breaker assembly.
5. Remove screws, boot, and ON-OFF load circuit breaker assembly from control panel.

END OF TASK**INSTALLATION**

1. Insert ON-OFF load circuit breaker assembly (Figure 1) into control panel.
2. Position boot over ON-OFF load circuit breaker assembly and secure both to control panel with screws.
3. Connect electrical leads to terminals on ON-OFF load circuit breaker assembly and remove tags.
4. Connect electrical leads for ON-OFF load circuit breaker assembly to TB1-2 and TB1-7 (MEP-531A) and remove tags.
5. Close and secure instrument panel.

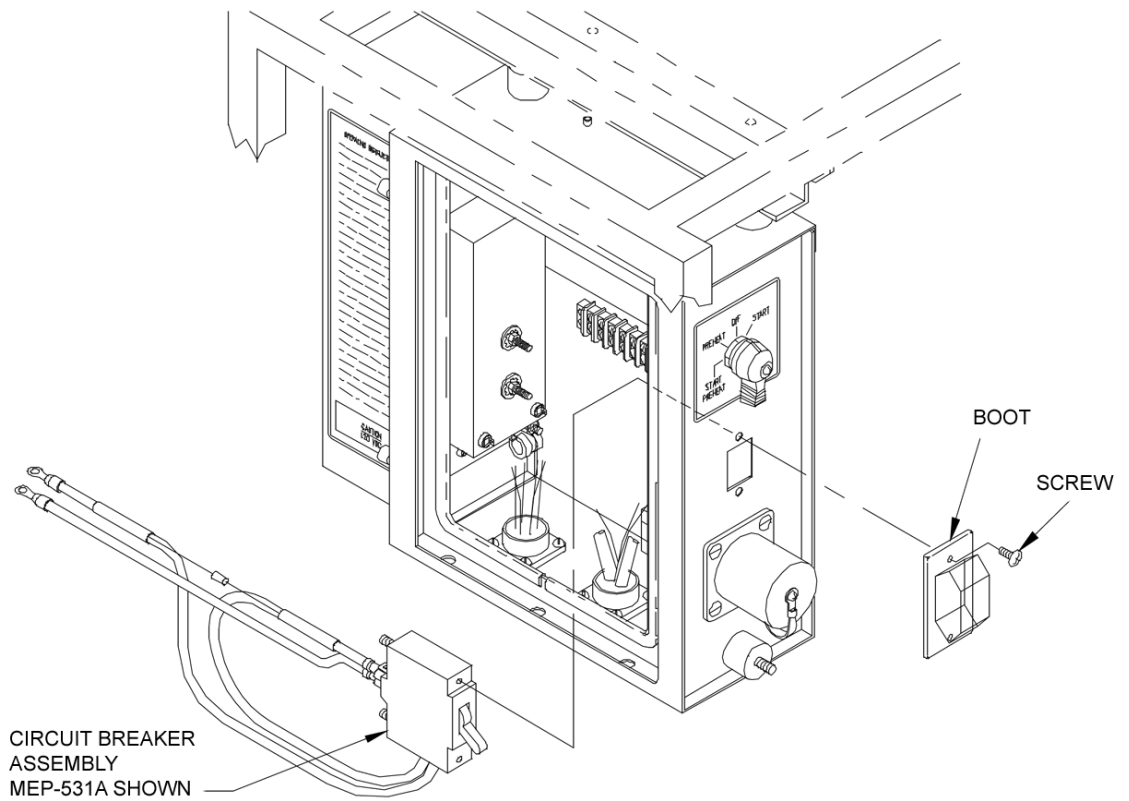

Figure 1. ON-OFF Load Circuit Breaker Assembly and Boot.

END OF TASK

END OF WORK PACKAGE

FIELD MAINTENANCE**2 kW MEP-501A/531A MILITARY TACTICAL GENERATOR SETS****FLYWHEEL DIODE ASSEMBLY: INSPECTION, TESTING, REMOVAL, REPAIR, INSTALLATION**

INITIAL SETUP:**Tools and Special Tools**

Tool Kit, General Mechanic's Automotive or Standard Automotive Tool Set (WP 0159, Table 2, Item 6)
Multimeter (WP 0159, Table 2, Item 3)

Materials/Parts

As required

References

WP 0059, Electromagnetic Interference (EMI) filter (MEP-531A)
WP 0101, Flywheel Diode Assembly (P/N: 95-8050)

Equipment Condition

Generator set shut down (WP 0005, Stopping Procedure)
Cable disconnected for NATO Slave Receptacle (WP 0005)

INSPECTION

1. Shut down generator set.
2. Release instrument panel by turning fastener. Open instrument panel slowly.
3. Visually inspect diode assembly for cracked or deteriorated insulation, broken terminals, and other damage.
4. Close and secure instrument panel.

END OF TASK**TESTING**

1. Shut down generator set.
2. Release instrument panel by turning fastener. Open instrument panel slowly.
3. Disconnect one end of flywheel diode assembly (CR1) at S2-S. Using multimeter set for ohms, test across disconnected end of CR1 to TB1-1. Then reverse leads and test again.
4. Resistance (ohms) readings should be high in one direction and low in the other direction. If readings are high or low in both directions, diode is defective and must be replaced.
5. Reconnect lead to S2-S.

END OF TASK**REMOVAL**

1. Shut down generator set.
2. Release instrument panel by turning fastener. Open instrument panel slowly.
3. Remove EMI filter, refer to WP 0059, Removal (MEP-531A).
4. Tag and disconnect flywheel diode assembly (Figure 1) at terminal board (TB1-1) and at START-PREHEAT/PREHEAT/OFF/START rotary switch (S2-S).

END OF TASK

REPAIR

Repair flywheel diode assembly by assembling the flywheel diode assembly and terminals in accordance with WP 0101.

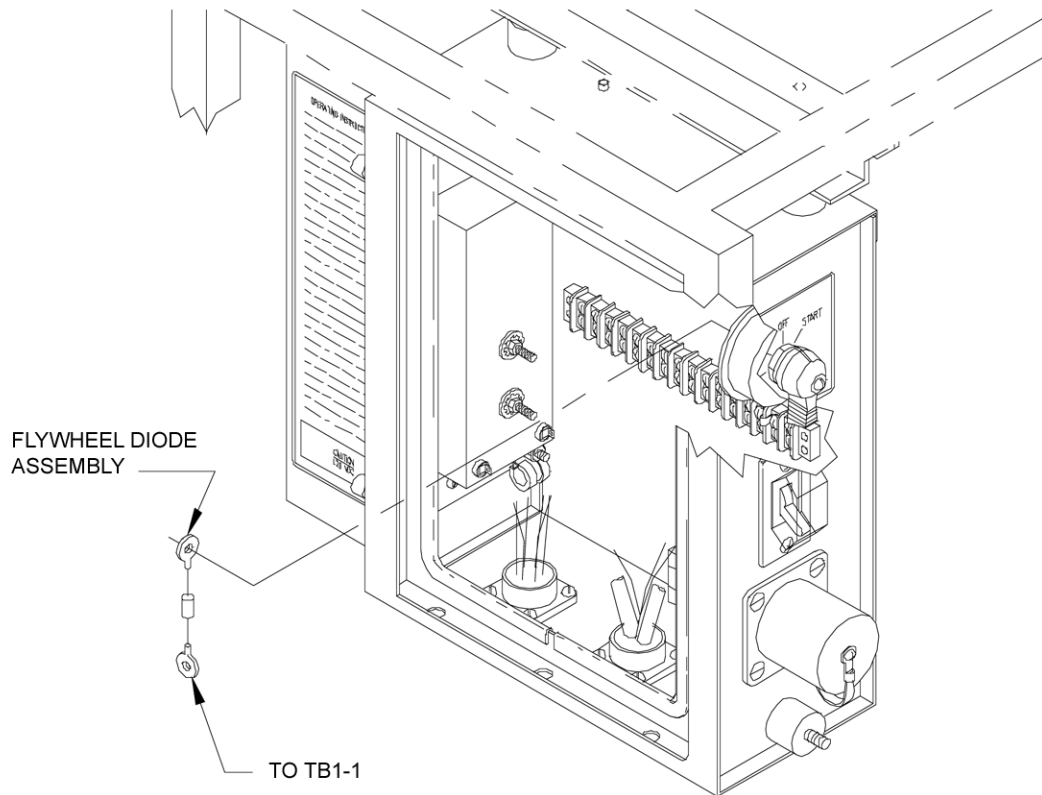

Figure 1. Flywheel Diode Assembly.

END OF TASK**INSTALLATION**

1. Connect flywheel diode assembly (Figure 1) at terminal board and at START-PREHEAT/PREHEAT/OFF/START rotary switch. Remove tags.
2. Install EMI filter, refer to WP 0059, Installation (MEP-531A).
3. Close and secure instrument panel.

END OF TASK**END OF WORK PACKAGE**

FIELD MAINTENANCE**2 kW MEP-501A/531A MILITARY TACTICAL GENERATOR SETS****DIESEL ENGINE WIRING HARNESS AND GASKET, CONTROL PANEL: INSPECTION, TESTING, REMOVAL, REPAIR, INSTALLATION**

INITIAL SETUP:**Tools and Special Tools**

Tool Kit, General Mechanic's Automotive or Standard Automotive Tool Set (WP 0159, Table 2, Item 6)
Multimeter (WP 0159, Table 2, Item 3)

Materials/Parts

As required

Equipment Condition

Generator set shut down (WP 0005, Stopping Procedure)
Cable disconnected for NATO Slave Receptacle (WP 0005)

INSPECTION

1. Shut down generator set.
2. Release instrument panel by turning fastener. Open instrument panel slowly.
3. Visually inspect control panel engine wiring harness wiring for cracked or deteriorated insulation, broken terminals, and other damage.
4. Visually inspect the engine wiring harness receptacle for security, cracks, broken wires, and other damage.
5. Close and secure instrument panel.

END OF TASK**TESTING**

1. Shut down generator set.
2. Release instrument panel by turning fastener. Open instrument panel slowly.
3. Disconnect engine wiring harness plug (P2) from receptacle (J2) of control panel engine wiring harness (Figure 1).
4. (MEP-531A). Set multimeter for ohms and check for continuity between J2 pin A and START-PREHEAT/PREHEAT/OFF/START switch (S2) pin H, J2 pin B and TB1 connector 3, J2 pin C and S2 pin S, J2 pin D and NATO slave receptacle (SR1) pin +, J2 pin E and TB1 connector 5, and J2 pin F and TB1 connector 6.
5. (MEP-501A). Set multimeter for ohms and check for continuity between J2 pin A and START-PREHEAT/PREHEAT/OFF/START switch (S2) pin H, J2 pin B and TB1 connector 4, J2 pin C and S2 pin S, J2 pin D and NATO slave receptacle (SR1) pin +, J2 pin E and TB1 connector 6, and J2 pin F and TB1 connector 7.
6. If necessary, repair wiring harness. Then connect engine wiring harness plug to control panel engine wiring harness receptacle.
7. Close and secure instrument panel.

END OF TASK

REMOVAL

1. Shut down generator set.
2. Release instrument panel by turning fastener. Open instrument panel slowly.
3. Disconnect engine wiring harness plug from receptacle of control panel engine wiring harness (Figure 1).
4. Cut cable ties as necessary.
5. (MEP-531A). Tag and disconnect electrical leads for control panel engine wiring harness from terminals 3, 5, and 6 of TB1, terminals S and H of PREHEATSTART\PREHEAT\OFF\ START rotary switch, and + terminal of NATO slave receptacle.
6. (MEP-501A). Tag and disconnect electrical leads for control panel engine wiring harness from terminals 4, 6, and 7 of TB1, terminals S and H of PREHEATSTART\PREHEAT\OFF\ START rotary switch, and + terminal of NATO slave receptacle.
7. Remove screws, lockwashers, washers, control panel engine wiring harness, and gasket from control panel.

END OF TASK**REPAIR**

1. Cut cable ties as necessary.
2. If replacing individual wires and/or connectors, tag and remove defective wires. Then install new cable ties as necessary and remove tags.

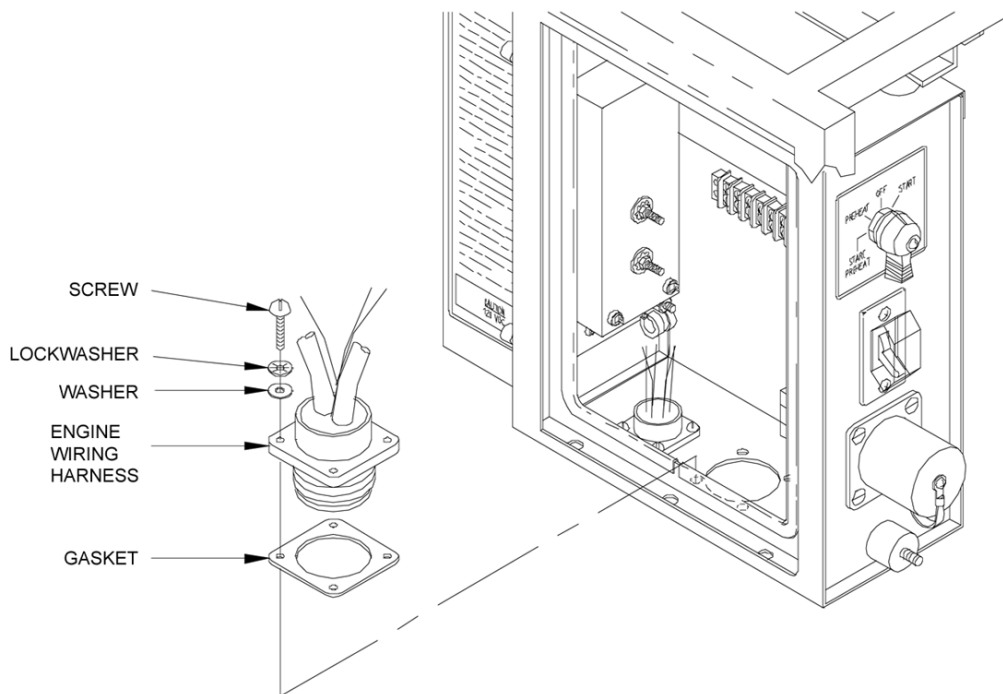

Figure 1. Diesel Engine Wiring Harness and Gasket, Control Panel.

END OF TASK**INSTALLATION**

1. Install gasket and control panel engine wiring harness in control panel with washers, lockwashers, and screws.

2. Connect engine wiring harness plug and control panel engine wiring harness electrical leads. Remove tags.
3. Replace cable ties as necessary.
4. Close and secure instrument panel.

END OF TASK

END OF WORK PACKAGE

FIELD MAINTENANCE**2 kW MEP-501A/531A MILITARY TACTICAL GENERATOR SETS****ALTERNATOR WIRING HARNESS AND GASKET, CONTROL PANEL: INSPECTION, TESTING, REMOVAL,
REPAIR, INSTALLATION**

INITIAL SETUP:**Tools and Special Tools**

Tool Kit, General Mechanic's Automotive or
Standard Automotive Tool Set
(WP 0159, Table 2, Item 6)
Multimeter (WP 0159, Table 2, Item 3)

Materials/Parts

As required

Equipment Condition

Generator set shut down (WP 0005, Stopping
Procedure)
Cable disconnected for NATO Slave Receptacle
(WP 0005)

INSPECTION

1. Shut down generator set.
2. Release instrument panel by turning fastener. Open instrument panel slowly.
3. Visually inspect control panel alternator wiring harness wiring for cracked or deteriorated insulation, broken terminals, and other damage.
4. Visually inspect the wiring harness receptacle for security, cracks, broken wires, and other damage.
5. Close and secure instrument panel.

END OF TASK**TESTING**

1. Shut down generator set.
2. Release instrument panel by turning fastener. Open instrument panel slowly.
3. Disconnect alternator wiring harness plug (P1) from receptacle (J1) of control panel alternator wiring harness (Figure 1).
4. (MEP-531A). Set multimeter for ohms and check for continuity between J1 pin A and TB1 connector 13, J1 pin B and EMI filter load terminal lug N, J1 pin C and TB1 connector 14, J1 pin D and TB1 connector 15, J1 pin E and TB1 connector 8, and J1 pin F and TB1 connector 9.
5. (MEP-501A). Set multimeter for ohms and check for continuity between J1 pin A and shunt resistor (R3), J1 pin B and TB1 connector 10, J1 pin D and TB1 connector 11, and J1 pin C and load terminal lug (-).
6. If necessary, repair wiring harness. Then connect alternator wiring harness plug to control panel alternator wiring harness receptacle.
7. Close and secure instrument panel.

END OF TASK**REMOVAL**

1. Shut down generator set.
2. Release instrument panel by turning fastener. Open instrument panel slowly.

3. Disconnect alternator wiring harness plug from receptacle of control panel alternator wiring harness (Figure 1).
4. Cut cable ties as necessary.
5. (MEP-531A). Tag and disconnect electrical leads for control panel alternator wiring harness from terminals 8, 9, 13, 14, and 15 of TB1, and Electromagnetic Interference (EMI) filter load terminal lug N.
6. (MEP-501A). Tag and disconnect electrical leads for control panel alternator wiring harness from terminals 10 and 11 of TB1, shunt resistor (R3), and load terminal lug (-).
7. Remove screws, lockwashers, washers, control panel alternator wiring harness, and gasket from control panel.
8. If necessary, remove threaded inserts from control panel.

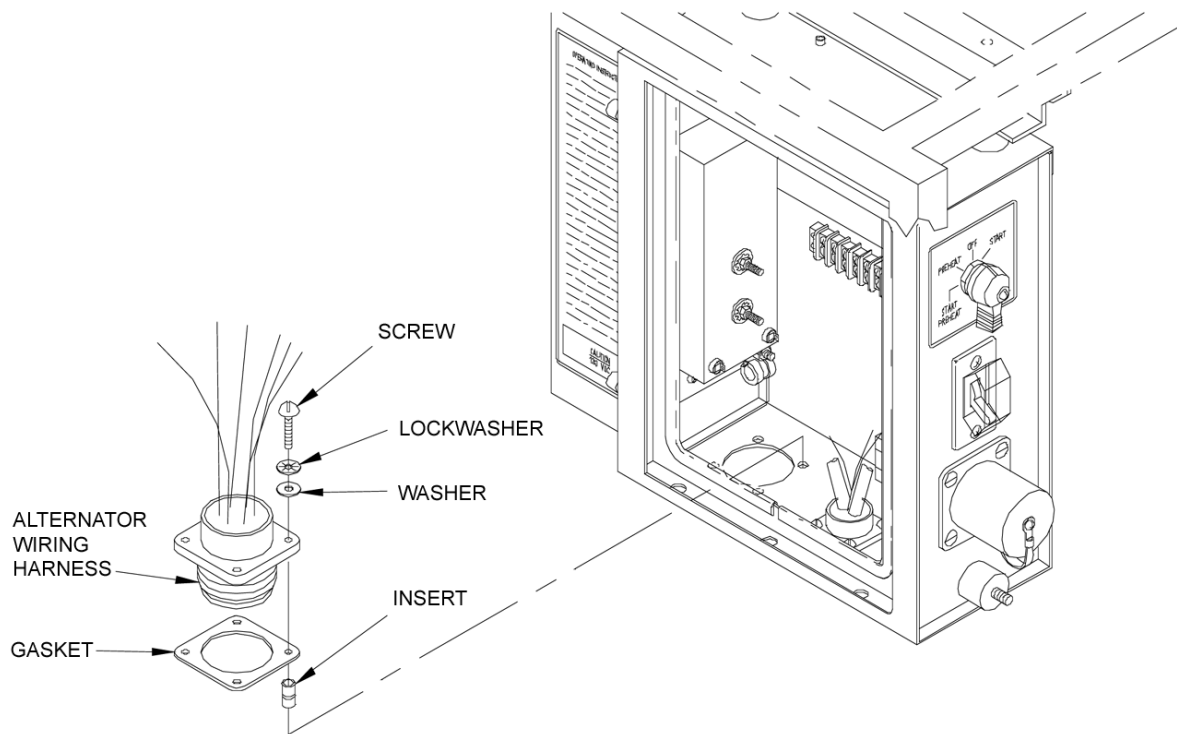

Figure 1. Alternator Wiring Harness and Gasket, Control Panel.

END OF TASK

REPAIR

1. Cut cable ties as necessary.
2. If replacing individual wires and/or connectors, tag and remove defective wires. Then install new cable ties as necessary and remove tags.

END OF TASK

INSTALLATION

1. If removed, install threaded inserts (Figure 1) in control panel.
2. Install gasket and control panel alternator wiring harness in control panel with washers, lockwashers, and screws.

3. Connect alternator wiring harness plug and control panel alternator wiring harness electrical leads. Remove tags.
4. Replace cable ties as necessary.
5. Close and secure instrument panel.

END OF TASK

END OF WORK PACKAGE

FIELD MAINTENANCE**2 kW MEP-501A/531A MILITARY TACTICAL GENERATOR SETS****ELECTRICAL LEAD WIRE(S) (TYPICAL): INSPECTION, TESTING, REMOVAL, INSTALLATION**

INITIAL SETUP:**Tools and Special Tools**

Tool Kit, General Mechanic's Automotive or Standard Automotive Tool Set (WP 0159, Table 2, Item 6)
Multimeter (WP 0159, Table 2, Item 3)

Materials/Parts

As required

References

WP 0097, Electrical Lead Fabrication for Control Panel

Equipment Condition

Generator set shut down (WP 0005, Stopping Procedure)
Cable disconnected for NATO Slave Receptacle (WP 0005)

INSPECTION

1. Shut down generator set.
2. Release instrument panel by turning fastener. Open instrument panel slowly.
3. Visually inspect control panel electrical leads for cracked or deteriorated insulation, broken terminals, and other damage.
4. Close and secure instrument panel.

END OF TASK**TESTING**

1. Shut down generator set.
2. Release instrument panel by turning fastener. Open instrument panel slowly.
3. Tag and disconnect control panel electrical lead (Figure 1).
4. Set multimeter for ohms and check wire for continuity.
5. Replace defective wires and electrical connectors. Refer to WP 0097, Table 1 (MEP-531A) or Table 2 (MEP-501A), for instructions on how to make each electrical lead.
6. Connect control panel electrical lead as tagged. Remove tags.
7. Close and secure instrument panel

END OF TASK**REMOVAL**

1. Shut down generator set.
2. Release instrument panel by turning fastener. Open instrument panel slowly.
3. Tag and disconnect control panel electrical lead (Figure 1) from terminals.

END OF TASK

INSTALLATION

1. Connect control panel electrical lead (Figure 1) as tagged. Remove tags.
2. Close and secure instrument panel.

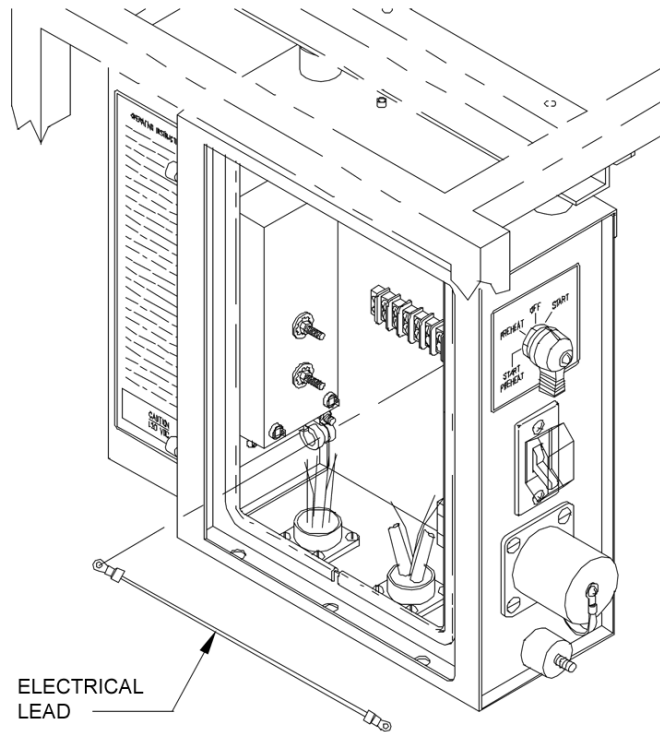

Figure 1. Electrical Lead Wire(s) (Typical).

END OF TASK

END OF WORK PACKAGE

FIELD MAINTENANCE

2 kW MEP-501A/531A MILITARY TACTICAL GENERATOR SETS

LOAD TERMINAL BOARD COVER (LUG COVER): INSPECTION, REMOVAL, REPAIR, INSTALLATION

INITIAL SETUP:

Tools and Special Tools

Tool Kit, General Mechanic's Automotive or Standard Automotive Tool Set (WP 0159, Table 2, Item 6)

Materials/Parts

Paper, Abrasive (WP 0162, Table 1, Item 17)
Adhesive, Contact (WP 0162, Table 1, Item 2)

References

WP 0162, Table 1, Item 17, and 2
TM 43-0139/TO 35-1-3

Equipment Condition

Generator set shut down (WP 0005, Stopping Procedure)
Cable disconnected for NATO Slave Receptacle (WP 0005)

WARNING

Chemical Agent Resistant Coating (CARC) paint dust is a health hazard. Wear protective eyewear, mask, and gloves when sanding CARC painted surfaces. Failure to comply can cause personal injury.

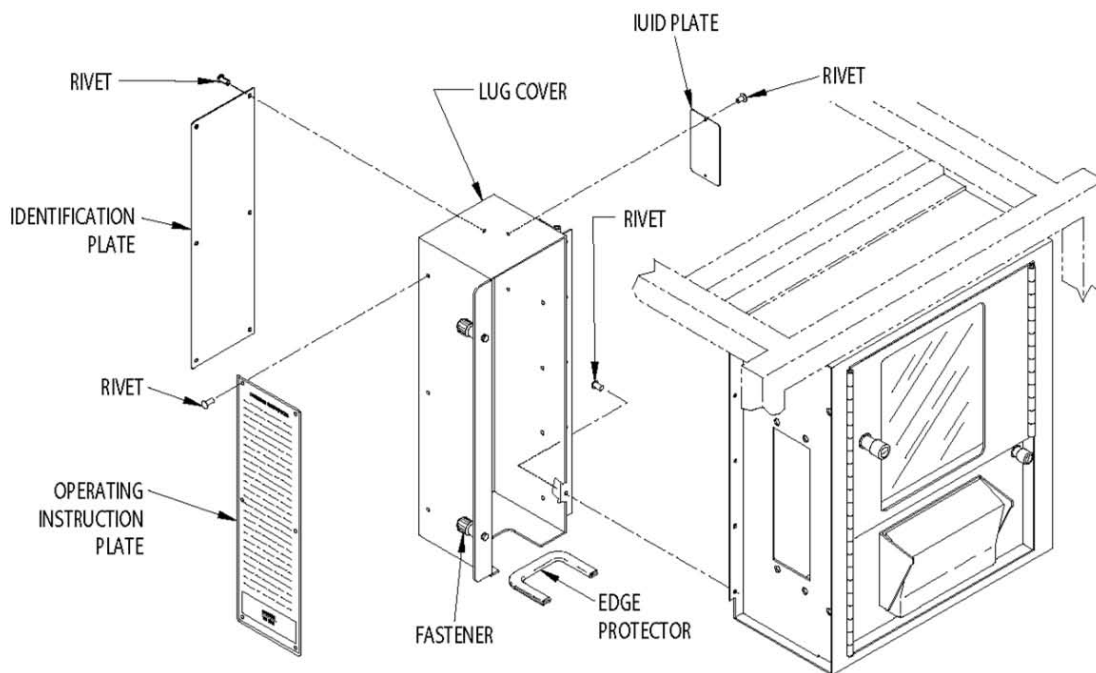

Figure 1. Load Terminal Board Cover (Lug Cover).

INSPECTION

1. Shut down generator set.
2. Inspect lug cover for security, cracks, corrosion, and other damage.

END OF TASK

REMOVAL

1. Shut down generator set.
2. Release lug cover by turning two fasteners. Open lug cover.
3. Remove rivets (Figure 1) and lug cover from control panel.
4. If necessary, remove rivets and operating instruction plate from lug cover.
5. If necessary, remove rivets and identification plate from lug cover.
6. If necessary, remove edge protector and adhesive residue from lug cover.

END OF TASK**REPAIR****WARNING**

Chemical Agent Resistant Coating (CARC) paint dust is a health hazard. Wear protective eyewear, mask, and gloves when sanding CARC painted surfaces. Failure to comply can cause personal injury.

1. Repair all dents and cracks, and remove all loose paint.
2. Remove light corrosion with fine grit abrasive paper (WP 0162, Table 1, Item 17).
3. Repaint surface in accordance with TM 43-0139/TO 35-1-3.

END OF TASK**INSTALLATION**

1. If removed, install edge protector (Figure 1) on lug cover with contact adhesive (WP 0162, Table 1, Item 2). Follow manufacturer' s instructions for application of contact adhesive.
2. If removed, install identification plate on lug cover with new rivets.
3. If removed, install operating instructions plate on lug cover with new rivets.
4. Install lug cover on control panel with new rivets.
5. Close and secure lug cover.

END OF TASK**END OF WORK PACKAGE**

FIELD MAINTENANCE**2 kW MEP-501A/531A MILITARY TACTICAL GENERATOR SETS****ELECTROMAGNETIC INTERFERENCE (EMI) FILTER (MEP-531A): INSPECTION, REMOVAL, TESTING,
INSTALLATION**

INITIAL SETUP:**Tools and Special Tools**

Tool Kit, General Mechanic's Automotive or
Standard Automotive Tool Set
(WP 0159, Table 2, Item 6)
Multimeter (WP 0159, Table 2, Item 3)

Materials/Parts

As required

Equipment Condition

Generator set shut down (WP 0005, Stopping
Procedure)
Cable disconnected for NATO Slave Receptacle
(WP 0005)

INSPECTION

1. Shut down generator set.
2. Release instrument panel by turning fastener. Open instrument panel slowly.
3. Release lug cover by turning two fasteners. Open lug cover.
4. Inspect load terminals of EMI filter for deformed threads, corrosion, and other physical damage.
5. Ensure connections to EMI filter inside of the control box are clean and tight. Clean and tighten if necessary.
6. Close and secure instrument panel.
7. Close and secure lug cover.

END OF TASK**REMOVAL**

1. Shut down generator set.
2. Release lug cover by turning two fasteners. Open lug cover.
3. Disconnect load cables from EMI filter load terminals as necessary.
4. Release instrument panel by turning fastener. Open instrument panel slowly.
5. Tag and disconnect two female quick-disconnects connected to bottom terminals on EMI filter (Figure 1).
6. Tag and disconnect one wire lead connected to "L" terminal and four wire leads connected to "N" terminal on EMI filter.
7. Remove screws, washers, lockwashers, and nuts securing bottom of EMI filter to control box. Note how instrument panel ground strap and wiring cable clamp are captured under the mounting hardware.
8. Remove nuts, lockwashers, and washers securing top of EMI filter to control box.
9. Remove EMI filter.

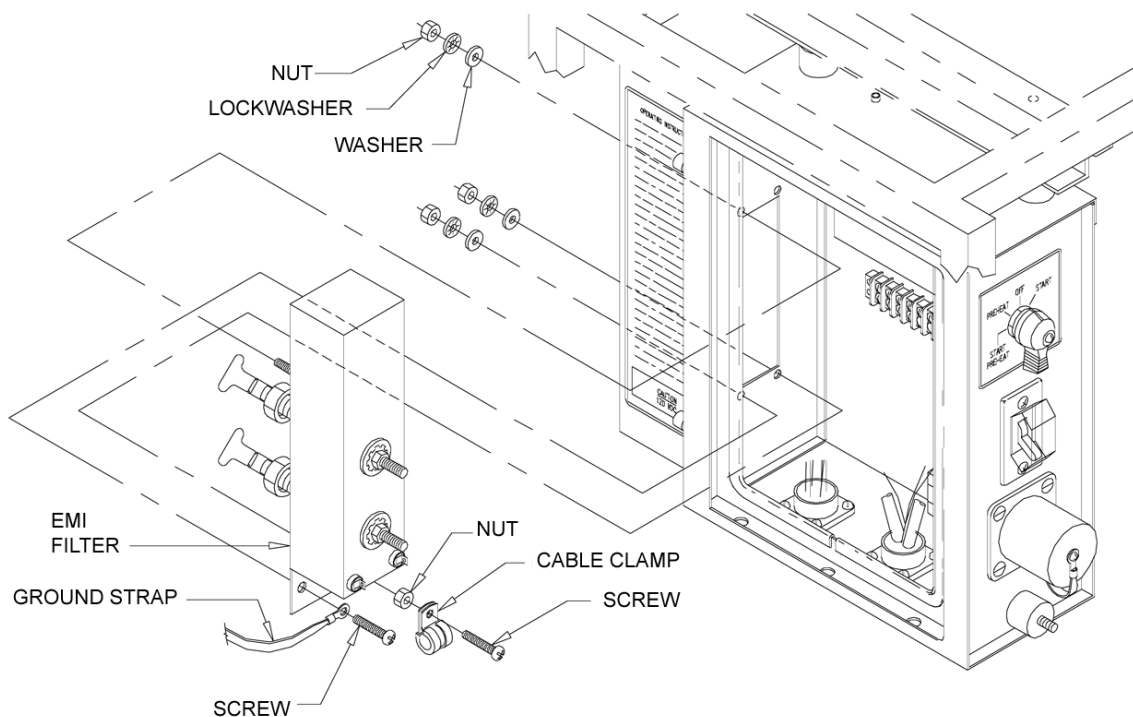

Figure 1. EMI Filter (MEP-531A).

END OF TASK

TESTING

1. Shut down generator set.
2. Release instrument panel by turning fastener. Open instrument panel slowly.
3. Release lug cover by turning two fasteners. Open lug cover.
4. Disconnect load cables from EMI filter load terminals as necessary.
5. Tag and disconnect two female quick-disconnects connected to bottom terminals on EMI filter (Figure 1).
6. Tag and disconnect one wire lead connected to "L" terminal and four wire leads connected to "N" terminal on EMI filter.
7. Using multimeter set for ohms, check for open circuit across two upper EMI filter terminals "L" and "N". If not open, EMI filter is defective.
8. Repeat Step 7 for "L" and "N" terminals that connect to the GFCI convenience receptacle (lower).
9. Using multimeter set for ohms, check for closed circuit across the lower "L" terminal (that connects to GFCI convenience receptacle) and load terminal "L". If not closed, EMI filter is defective.
10. Repeat Step 9 for the lower "N" terminal (that connects to GFCI convenience receptacle) and load terminal "N".
11. Reconnect wire leads as tagged.
12. Close and secure instrument panel.
13. Reconnect load cables to EMI filter load terminals as necessary.
14. Close and secure lug cover.

END OF TASK

INSTALLATION

1. Install EMI filter (Figure 1) in control panel cutout with mounting studs on filter through holes in panel.
2. Secure top of EMI filter to control panel with nuts, lockwashers, and washers.
3. Secure bottom of EMI filter with screws, washers, lockwashers, and nuts. Be sure to secure instrument panel ground strap and cable clamp as noted during removal.
4. Connect one wire lead to "L" terminal and four wire leads to "N" terminal on EMI filter as tagged. Remove tags.
5. Connect two quick-disconnects to bottom two terminals on EMI filter as tagged. Remove tags.
6. Connect load cables to EMI filter load terminals, if applicable.
7. Close and secure instrument panel and cover.

END OF TASK**END OF WORK PACKAGE**

FIELD MAINTENANCE

2 kW MEP-501A/531A MILITARY TACTICAL GENERATOR SETS

LOW OIL PRESSURE (LOP) SWITCH: TESTING, REMOVAL, INSTALLATION

INITIAL SETUP:

Tools and Special Tools

Tool Kit, General Mechanic's Automotive or Standard Automotive Tool Set (WP 0159, Table 2, Item 6)
Multimeter (WP 0159, Table 2, Item 3)

Materials/Parts

Sealant, Thread Compound (WP 0162, Table 1, Item 21)

References

WP 0162, Table 1, Item 21

Equipment Condition

Generator set shut down (WP 0005, Stopping Procedure)
Cable disconnected for NATO Slave Receptacle (WP 0005)

TESTING

1. Shut down generator set.
2. Disconnect and isolate electrical lead from LOP switch (Figure 1).

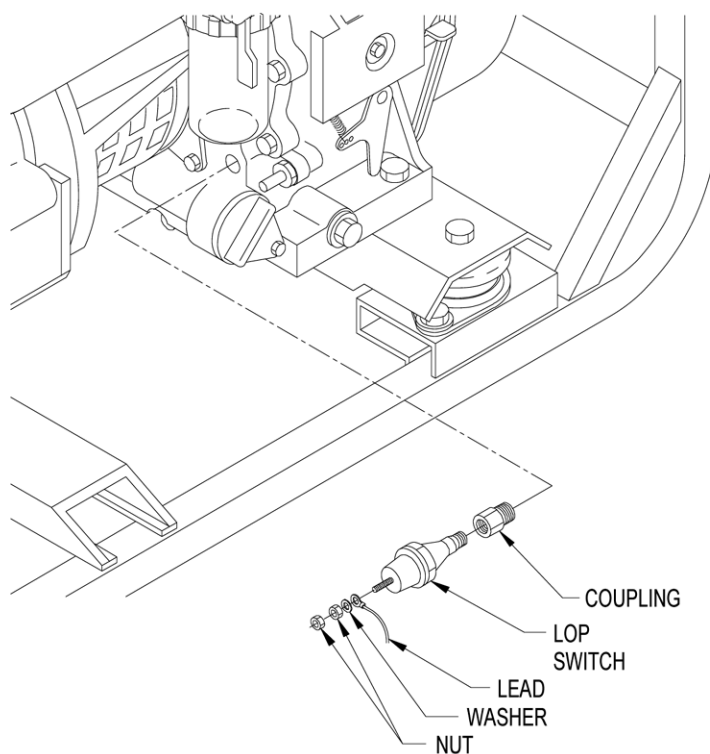

Figure 1. Low Oil Pressure (LOP) Switch.

3. Using multimeter set for ohms, check for continuity between LOP switch terminal and ground. If continuity is not indicated, switch is defective and must be replaced.
4. Start generator set.

5. Using multimeter set for ohms, check for continuity between LOP switch terminal and ground. If continuity is indicated, switch is defective and must be replaced.
6. Shut down generator set and connect electrical lead.

CAUTION

For the Mechron sets, a serious risk of cross-threading exists.

- a. On the Mechron 28 VDC sets, the LOP switch, which has standard threads, is screwed directly into metric threads in the engine block. Use extreme caution when removing. Add coupler listed in this TM when replacing LOP switch.
- b. On the Mechron 120 VAC sets, the original coupler has standard threading on both sides. This coupler is screwed directly into metric threads in the engine lock. Use extreme caution when removing. Replace coupler with one listed in this TM.
- c. In the event of cross-threading, the engine opening will need to be re-tapped. Remove crankcase cover, following TM procedures and do not contaminate internal engine housing with metal filings.

END OF TASK

REMOVAL

1. Shut down generator set and drain diesel engine oil.
2. Cut tie wraps as necessary. Then disconnect electrical lead from LOP switch (Figure 1).
3. Remove LOP switch and coupling by unscrewing coupling from diesel engine block.
4. Separate LOP switch and coupling.

END OF TASK

INSTALLATION

1. Apply thread sealant (WP 0162, Table 1, Item 21) to threads of LOP switch (Figure 1). Then assemble LOP switch and coupling.
2. Apply thread sealant (WP 0162, Table 1, Item 21) to threads of coupling. Then install coupling in diesel engine block.
3. Connect electrical lead.
4. Use tie wraps to secure wiring to LOP shutdown cable as removed.
5. Service diesel engine oil.

END OF TASK

END OF WORK PACKAGE

FIELD MAINTENANCE**2 kW MEP-501A/531A MILITARY TACTICAL GENERATOR SETS****LOW OIL PRESSURE (LOP) SOLENOID ASSEMBLY: TESTING, REMOVAL, CLEANING AND INSPECTION, REPAIR, INSTALLATION**

INITIAL SETUP:**Tools and Special Tools**

Tool Kit, General Mechanic's Automotive or Standard Automotive Tool Set (WP 0159, Table 2, Item 6)
Power Source (24 VDC)

Materials/Parts

Cloth, Cleaning (WP 0162, Table 1, Item 4)
Solvent, Cleaning (WP 0162, Table 1, Item 20)

References

WP 0103, LOP Solenoid Valve Assembly (P/N: 95-8019)
WP 0162, Tabel 1, Item 4, and 20

Equipment Condition

Generator set shut down (WP 0005, Stopping Procedure)
Cable disconnected for NATO Slave Receptacle (WP 0005)

WARNING

High voltage is produced when this generator set is in operation. Use care when working around an open control panel with the generator set operating. Improper operation and/or failure to follow this warning could result in personal injury or death by electrocution.

WARNING

When using compressed air, wear protective glasses and use clean, low-pressure air, 30 psi (206.8 kPa) maximum. Failure to follow these instructions could result in eye injury.

WARNING

Cleaning solvents are flammable and toxic to eyes, skin, and respiratory tract. Skin/eye protection required. Avoid repeated/prolonged contact. Good general ventilation is normally adequate.

TESTING

1. Shut down generator set
2. Release instrument panel by turning fastener. Open instrument panel slowly.
3. Tag and disconnect electrical leads for LOP solenoid from terminals 2 and 4 of TB1 (MEP-531A) or terminals 3 and 5 of TB1 (MEP-501A).
4. Apply 24 VDC power source to disconnected wires (positive lead to wire disconnected from terminal 4 (MEP-531A) or terminal 5 (MEP-501A)). LOP solenoid should activate.
5. If LOP solenoid does not activate, replace solenoid.
6. Connect electrical leads, remove tags, close and secure instrument panel.

END OF TASK**REMOVAL**

1. Shut down generator set.
2. Release instrument panel by turning fastener. Open instrument panel slowly.
3. Tag and disconnect electrical leads for LOP solenoid from terminals 2 and 4 of TB1 (MEP-531A) or terminals 3 and 5 of TB1 (MEP-501A).

4. Remove screws (Figure 1), lockwashers, washers, and LOP solenoid from control panel.
5. Loosen screw(s) attaching LOP engine shutdown cable to LOP solenoid plunger.

END OF TASK

CLEANING

1. Remove LOP solenoid. Refer to Removal.

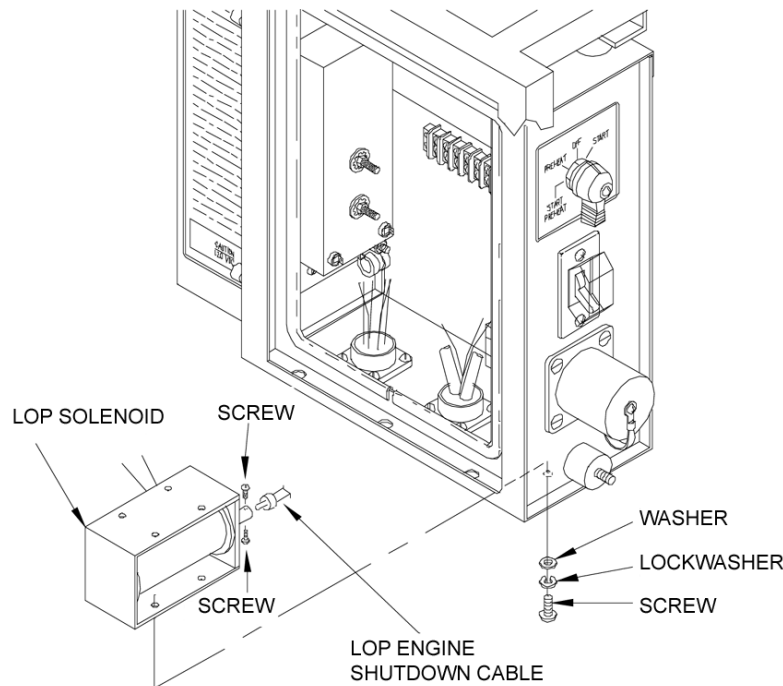

Figure 1. Low Oil Pressure (LOP) Solenoid Assembly.

WARNING

When using compressed air, wear protective glasses and use clean, low-pressure air, 30 psi (206.8 kPa) maximum. Failure to follow these instructions could result in eye injury.

WARNING

Cleaning solvents are flammable and toxic to eyes, skin, and respiratory tract. Skin/eye protection required. Avoid repeated/prolonged contact. Good general ventilation is normally adequate.

2. Clean LOP solenoid with dry, filtered, compressed air and electrician' s brush or wipe with cleaning cloth (WP 0162, Table 1, Item 4) lightly moistened with an approved cleaning solvent (WP 0162, Table 1, Item 20).
3. Inspect LOP solenoid for cracked casing, stripped or damaged threads, corrosion, deterioration of coil insulation, or other damage.
4. Install LOP solenoid. Refer to Installation Instructions.

END OF TASK

REPAIR

Repair LOP solenoid by cutting wires and installing terminals in accordance with WP 0103.

END OF TASK**INSTALLATION**

1. Install LOP solenoid (Figure 1) in control panel, ensuring LOP solenoid plunger is attached to LOP engine shutdown cable and is inserted in solenoid, with washers, lockwashers, and screws.
2. Connect electrical leads and remove tags.
3. Close and secure instrument panel.

END OF TASK**END OF WORK PACKAGE**

FIELD MAINTENANCE

2 kW MEP-501A/531A MILITARY TACTICAL GENERATOR SETS

LOW OIL PRESSURE (LOP) ENGINE SHUTDOWN CABLE: INSPECTION, REMOVAL, INSTALLATION, ADJUSTMENT

INITIAL SETUP:

Tools and Special Tools

Tool Kit, General Mechanic's Automotive or Standard Automotive Tool Set (WP 0159, Table 2, Item 6)

Materials/Parts

As required

References

WP 0109, LOP Shutdown Cable (P/N: 95-8082)

Equipment Condition

Generator set shut down (WP 0005, Stopping Procedure)
Cable disconnected for NATO Slave Receptacle (WP 0005)

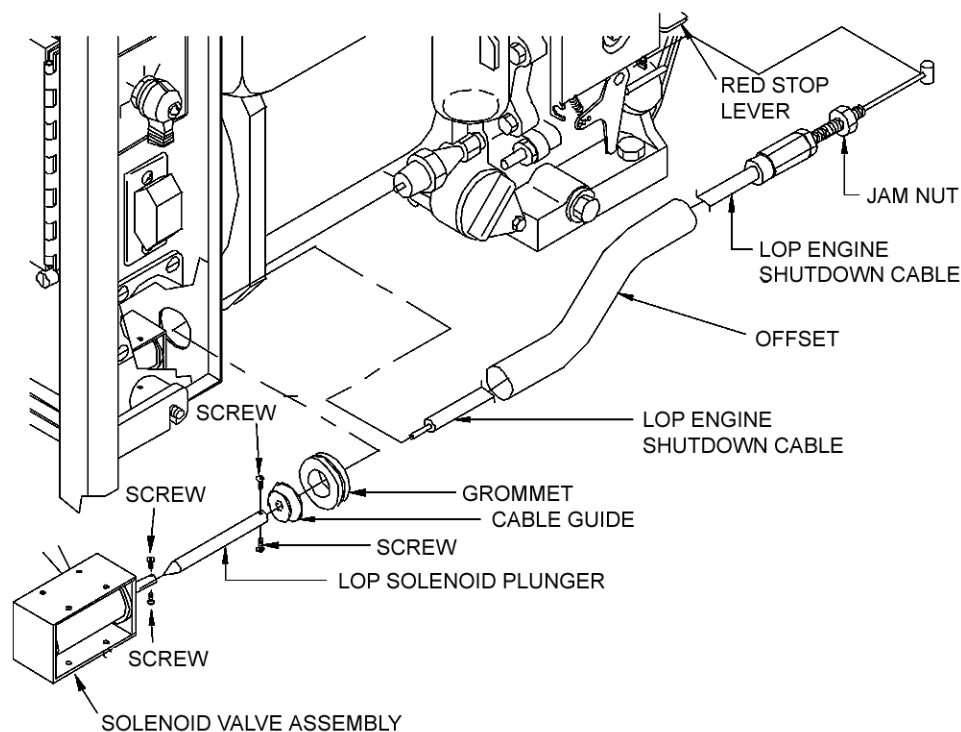

Figure 1. Low Oil Pressure (LOP) Engine Shutdown Cable.

INSPECTION

1. Shut down generator set.
2. Inspect LOP engine shutdown cable for security, broken cover, corrosion, and other damage.
3. Replace LOP engine shutdown cable if damaged.

4. Check adjustment of LOP engine shutdown cable. Refer to Adjustment.

END OF TASK

REMOVAL

1. Shut down generator set.
2. Cut cable ties securing LOP engine shutdown cable (Figure 1) to engine harness.
3. Using flat tip screwdriver, pry open ears on red STOP lever (Figure 1) and disconnect LOP engine shutdown cable from red STOP lever and governor regulator bracket (Figure 1).
4. Release instrument panel by turning fastener. Open instrument panel slowly.
5. Pull LOP engine shutdown cable, with cable guide and LOP solenoid plunger attached, from grommet in control panel assembly.
6. If necessary, loosen screws and remove LOP solenoid plunger and cable guide from LOP engine shutdown cable.
7. If necessary, remove offset from LOP engine shutdown cable.
8. If necessary, remove grommet from control panel assembly.

END OF TASK

INSTALLATION

1. If removed, install grommet (Figure 1) in control panel assembly.
2. If removed, install offset over LOP engine shutdown cable.

CAUTION

If installing new LOP engine shut down cable, ensure inner cable is cut to a length of 16.54 in. (420.1 mm). If cable is too long it may not trip stop lever when LOP solenoid actuates. Refer to WP 0109 for instructions on how to make the LOP shutdown cable.

3. If removed, install cable guide on LOP engine shutdown cable.
4. If removed, install LOP solenoid plunger on LOP engine shutdown cable with screws. Ensure cable is bottomed out in plunger before tightening screws.
5. Insert LOP engine shutdown cable through grommet ensuring that LOP solenoid plunger enters cylinder of LOP solenoid.
6. Seat cable guide in grommet.
7. Close and secure instrument panel.
8. Connect LOP engine shutdown cable to red STOP lever and governor regulator bracket. Pinch ears on red STOP lever to capture LOP engine shutdown cable.
9. Install cable ties as necessary to secure LOP engine shutdown cable to engine harness.
10. Check adjustment of LOP engine shutdown cable. Refer to Adjustment.

END OF TASK

ADJUSTMENT

1. For Adjustment, see Figure 2.

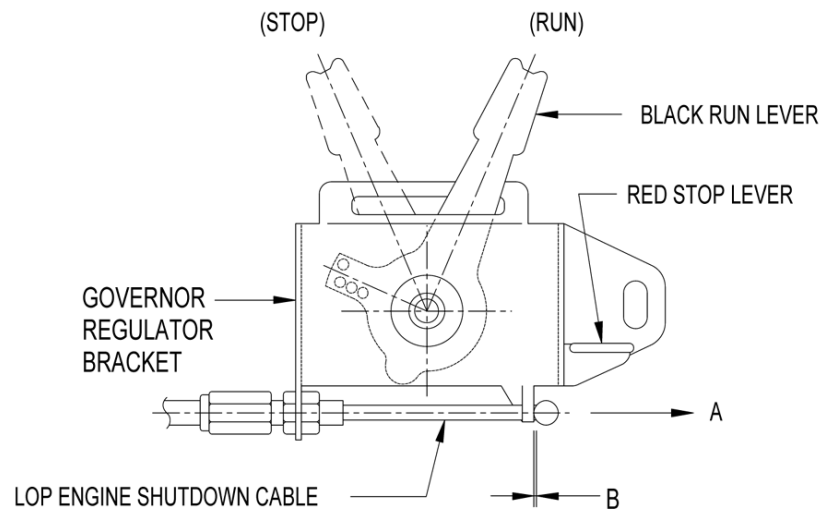

Figure 2. LOP Engine Shutdown Cable Adjustment.

2. Place engine RUN lever to RUN position.
3. Pull slack from LOP engine shutdown cable in direction of arrow A.
4. Measure for dimension B [0-0.02 in. (0-0.5 mm)].
5. Pull cable from LOP solenoid and grommet. Remove LOP solenoid plunger, cut cable as necessary to achieve dimension B. Attach LOP solenoid plunger to LOP engine shutdown cable and install cable in LOP solenoid and grommet.
6. Return engine RUN lever to STOP position.

END OF TASK

END OF WORK PACKAGE

FIELD MAINTENANCE**2 kW MEP-501A/531A MILITARY TACTICAL GENERATOR SETS****AIR INTAKE HEATING ELEMENTS AND PIPE: REMOVAL, INSPECTION, TESTING, INSTALLATION**

INITIAL SETUP:**Tools and Special Tools**

Tool Kit, General Mechanic's Automotive or Standard Automotive Tool Set (WP 0159, Table 2, Item 6)
Multimeter (WP 0159, Table 2, Item 3)

Materials/Parts

Compound, Locking (WP 0162, Table 1, Item 7)

References

WP 0030, Air Intake System Components
WP 0065, Cooling Fan Cover
WP 0162, Table 1, Item 7

Equipment Condition

Generator set shut down (WP 0005, Stopping Procedure)
Cable disconnected for NATO Slave Receptacle (WP 0005)
Air System Components removed (WP 0030)
Cover, Diesel Engine Cooling Fan removed (WP 0065)

REMOVAL

1. Shut down generator set.
2. Remove air intake system components, refer to WP 0030, Removal.
3. Tag and disconnect electrical leads from air intake heating elements (Figure 1).
4. Remove screws, mounting plate, gaskets, and air intake heating elements from spacer.
5. Remove jumper and separate air intake heating elements and gasket.
6. Remove nuts and spacer from air intake pipe.
7. Remove diesel engine cooling fan cover, refer to WP 0065, Removal.
8. Remove capscrew, air intake pipe, and gasket from cylinder head.
9. If necessary, remove stud from air intake pipe.

END OF TASK**INSPECTION**

1. Inspect air intake heating elements for cracks, damaged heating elements, corrosion, and other damage.
2. Inspect air intake pipe for cracks, corrosion, stripped threads, and other damage.
3. Inspect gaskets for tears and other damage.
4. Inspect mounting plate and spacer for cracks and other damage.
5. Replace damaged parts.

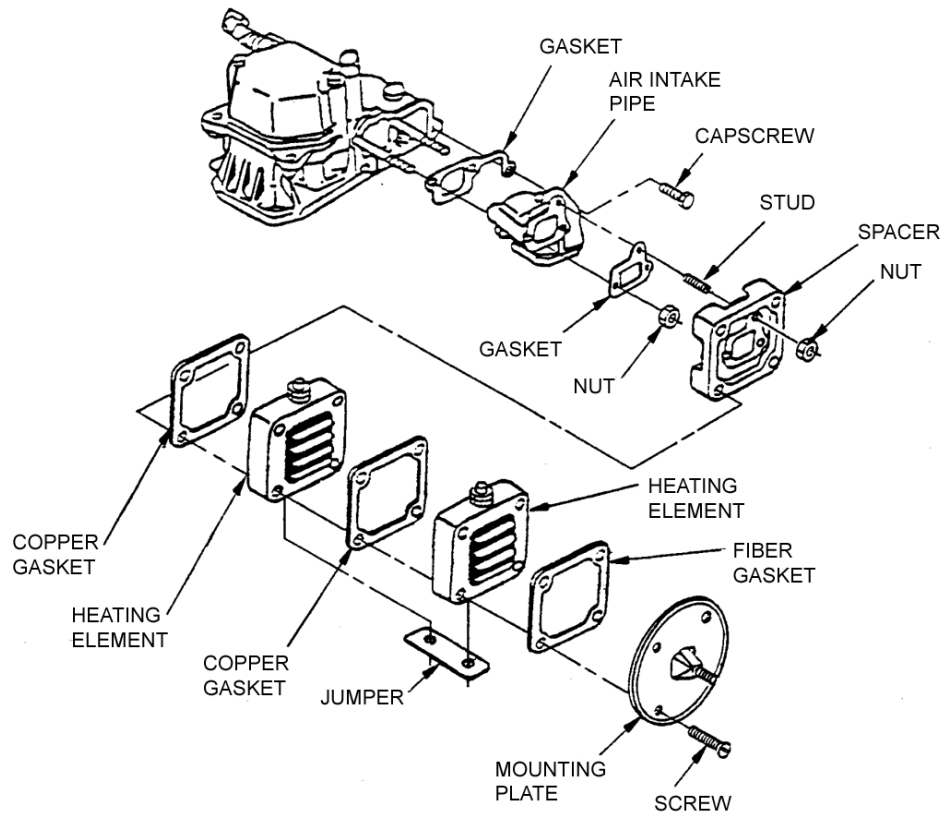

Figure 1. Air Intake Heating Elements and Pipe.

END OF TASK

TESTING

1. Using multimeter set for ohms, check for continuity across air intake heating element (HTR2) terminals. If circuit is open, element is defective.
2. Using multimeter set for ohms, check for continuity across air intake heating element (HTR1) terminals. If circuit is open, element is defective.

END OF TASK

INSTALLATION

1. If removed, install stud (Figure 1) in air intake pipe.

CAUTION

Do not overtighten capscrew.

2. Install gasket and air intake pipe on cylinder head with capscrew.
3. Install diesel engine cooling fan cover, refer to WP 0065, Installation.
4. Install spacer on air intake pipe with nuts.
5. Position gasket between air intake heating elements and secure together with jumper.

6. Install gaskets, air intake heating elements, and mounting plate on spacer with screws. Use locking compound (WP 0162, Table 1, Item 7) to secure machine screws in mounting plate. If damaged, replace machine screw in mounting plate.
7. Install air intake system components, refer to WP 0030, Installation.
8. Connect electrical leads and remove tags.

END OF TASK

END OF WORK PACKAGE

FIELD MAINTENANCE**2 kW MEP-501A/531A MILITARY TACTICAL GENERATOR SETS****GOVERNOR REGULATOR BRACKET: REMOVAL, INSPECTION, REPAIR, INSTALLATION**

INITIAL SETUP:**Tools and Special Tools**

Tool Kit, General Mechanic's Automotive or
Standard Automotive Tool Set
(WP 0159, Table 2, Item 6)

Materials/Parts

Governor Regulator Seal
Grounding Equipment

Personnel Required

91D

References

WP 0004, Description and Use of Operator Controls
and Indicators
WP 0062, Figure 2
WP 0062, Low Oil Pressure (LOP) engine Shutdown
Cable: Adjustment

Equipment Condition

Engine control switch off (WP 0004, Table 1)

REMOVAL

1. Shut down generator set.
2. Using flat tip screwdriver, pry open ears on red STOP lever and disconnect LOP engine shutdown cable (WP 0062, Figure 2) from STOP lever (Figure 1) and regulator bracket (3).
3. Remove bolt (1), bolt (2), and regulator bracket (3), with STOP lever attached, from cylinder block.
4. Disconnect spring (9) and spring (10) from governor lever (5).
5. If governor lever (5) is damaged or seal (12) is leaking, remove pin (4), governor lever (5), and thrust plate (6) from governor shaft.
6. Remove springs (9 and 10) from regulator bracket (3).
7. If necessary, remove seal (12) from cylinder block.

END OF TASK**INSPECTION**

1. Inspect components for cracks, corrosion and other damage.
2. Inspect springs for deformation.
3. Replace damaged parts.

END OF TASK**REPAIR**

Replace spring(s) if damaged or missing.

END OF TASK**INSTALLATION**

1. If removed, press new seal (Figure 1, Item 12) into cylinder block.

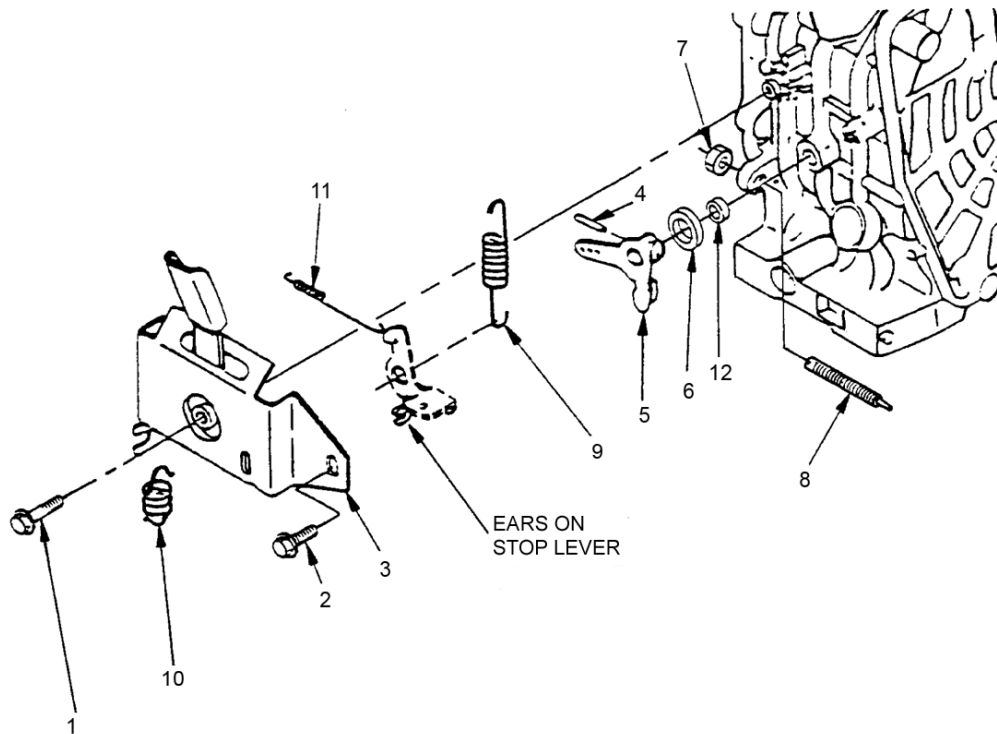

LEGEND

1 Bolt	7 Nut
2 Bolt	8 Screw
3 Bracket	9 Spring
4 Pin	10 Spring
5 Governor Lever	11 Spring
6 Thrust Plate	12 Seal

Figure 1. Governor Regulator Bracket.

2. If removed, position thrust plate (6) and governor lever (5) on governor shaft.
3. Secure governor lever (5) to governor shaft with new pin (4).
4. Attach springs (9 and 10) to regulator bracket (3) ensuring spring (9) is connected to lower outer hole on run lever, refer to Figure 2.
5. Connect springs (Figure 1, Items 9 and 10) to governor lever (5). Ensure spring (9) is connected in middle hole of governor lever arm, refer to Figure 2.
6. Install regulator bracket (Figure 1, Item 3), with STOP lever attached, on cylinder block with bolt (2) and bolt (1).
7. Connect LOP engine shutdown cable to STOP lever and regulator bracket (3). Pinch ears on red STOP lever to capture LOP shutdown cable. Adjust LOP shutdown cable as necessary, refer to WP 0062, Adjustment.
8. To adjust diesel engine speed and generator set frequency, loosen pivot screw on regulator bracket and move regulator bracket down to increase speed (frequency) or up to decrease speed.

NOTE

Breaking seal on screw (8) to remove or adjust voids engine warranty.

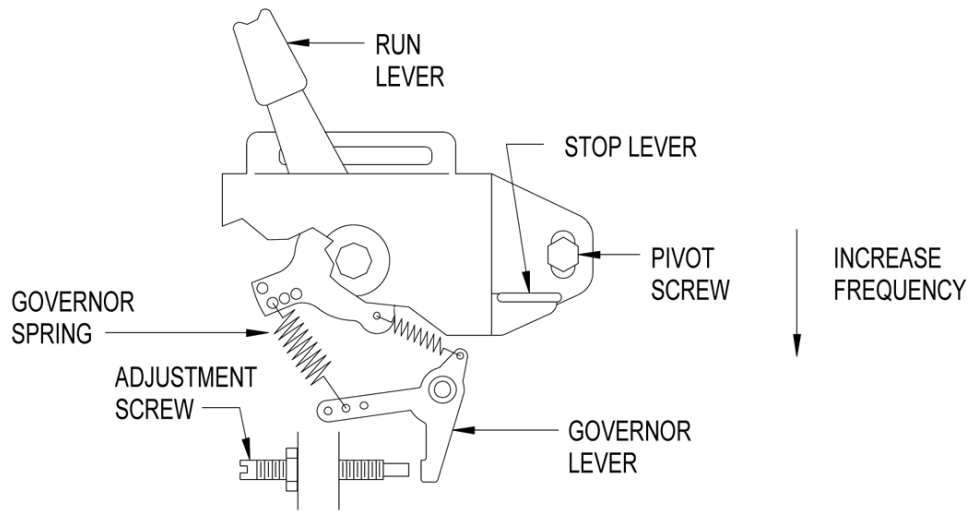

Figure 2. Governor Spring Positioning.

END OF TASK

END OF WORK PACKAGE

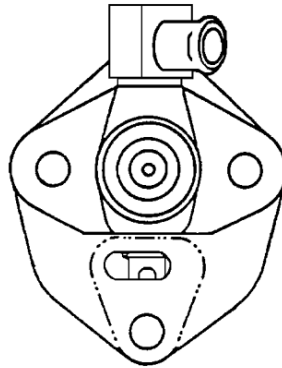

Figure 3. Fuel Injection Pump Mounting Flange.

FIELD MAINTENANCE**2 kW MEP-501A/531A MILITARY TACTICAL GENERATOR SETS
COOLING FAN COVER: INSPECTION, REMOVAL, REPAIR, INSTALLATION**

INITIAL SETUP:**Tools and Special Tools**

Tool Kit, General Mechanic's Automotive or Standard Automotive Tool Set (WP 0159, Table 2, Item 6)

Materials/Parts

Paper, Abrasive (WP 0162, Table 1, Item 17)

References

WP 0018, Air Filter Element Replacement
WP 0066, Recoil Starter Assembly
WP 0162, Table 1, Item 7
TM 43-0139/TO 35-1-3

Equipment Condition

Generator set shut down (WP 0005, Stopping Procedure)
Cable disconnected for NATO Slave Receptacle (WP 0005)
Air Cleaner Cover removed (WP 0018)

WARNING

Chemical Agent Resistant Coating (CARC) paint dust is a health hazard. Wear protective eyewear, mask, and gloves when sanding CARC painted surfaces. Failure to comply can cause personal injury.

INSPECTION

1. Shut down generator set.
2. Inspect cooling fan cover for security, cracks, corrosion, and other damage.

END OF TASK**REMOVAL**

1. Shut down generator set.
2. Remove air cleaner cover, refer to WP 0018, Removal.
3. Remove capscrews (Figure 1), washers, couplings, rubber retainers, cooling fan cover with recoil starter assembly, and seal from engine.
4. If necessary, remove recoil starter assembly, refer to WP 0066, Removal.

END OF TASK**REPAIR****WARNING**

Chemical Agent Resistant Coating (CARC) paint dust is a health hazard. Wear protective eyewear, mask, and gloves when sanding CARC painted surfaces. Failure to comply can cause personal injury.

1. Remove all loose paint.
2. Remove light corrosion with fine grit abrasive paper (WP 0162, Table 1, Item 17).
3. Repaint surface in accordance with TM 43-0139/TO 35-1-3.

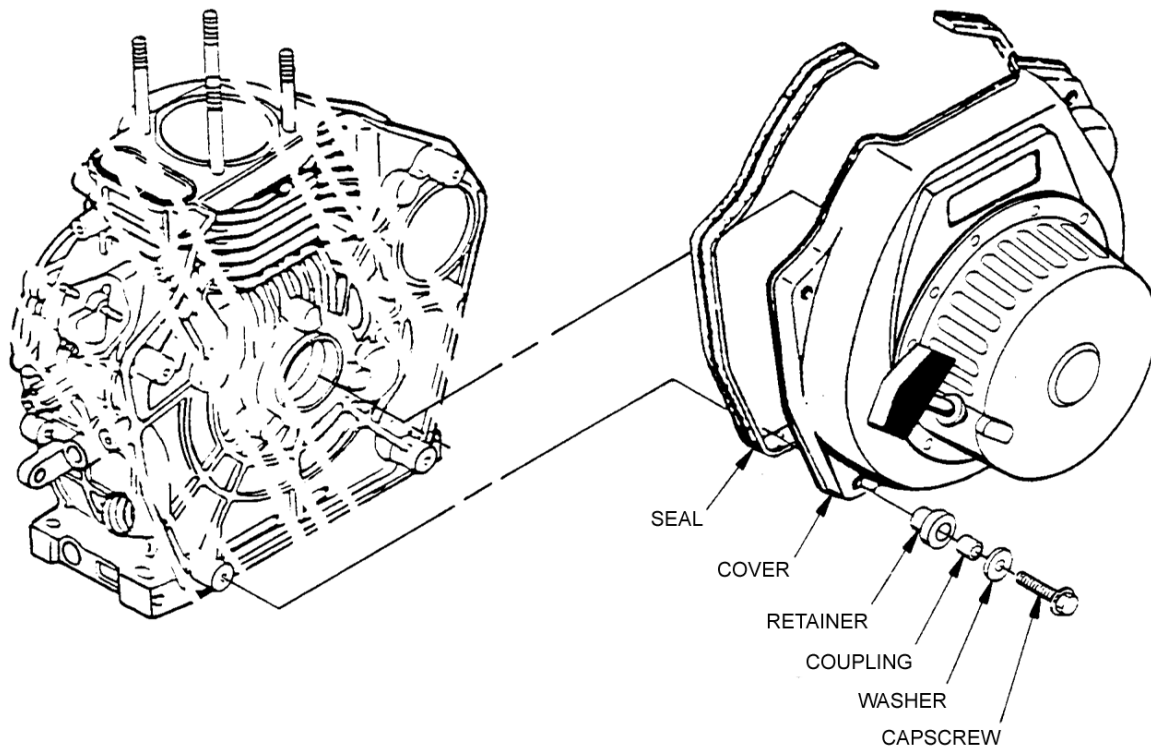

Figure 1. Cooling Fan Cover.

END OF TASK

INSTALLATION

1. If removed, install recoil starter assembly, refer to WP 0066, Installation.
2. Install seal (Figure 1) and cooling fan cover on engine with rubber retainers, couplings, washers, and capscrews.
3. Install air cleaner cover, refer to WP 0018, Installation.

END OF TASK

END OF WORK PACKAGE

FIELD MAINTENANCE**2 kW MEP-501A/531A MILITARY TACTICAL GENERATOR SETS****RECOIL STARTER ASSEMBLY: INSPECTION, REMOVAL, INSTALLATION**

INITIAL SETUP:**Tools and Special Tools**

Tool Kit, General Mechanic's Automotive or
Standard Automotive Tool Set
(WP 0159, Table 2, Item 6)

Materials/Parts

Governor Regulator Seal
Grounding Equipment

Personnel Required

91D

References

WP 0004, Description and Use of Operator Controls
and Indicators

Equipment Condition

Engine control switch off (WP 0004, Table 1)

INSPECTION

1. Shut down generator set.
2. Inspect recoil starter assembly for security, cracked housing, corrosion, frayed rope, obstructions, and other damage.

END OF TASK**REMOVAL**

1. Shut down generator set.
2. Note position of recoil starter assembly (Figure 1) to engine.
3. Remove capscrews and recoil starter assembly from engine.
4. If necessary, remove capscrews and pulley from engine flywheel.

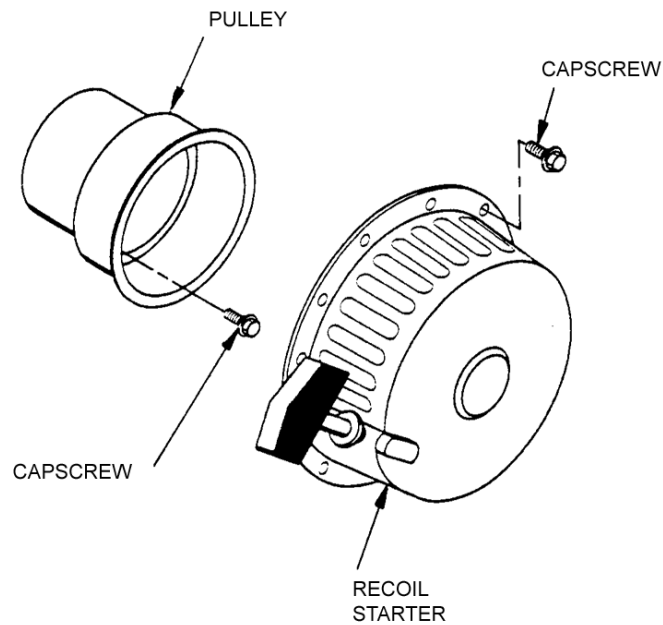

Figure 1. Recoil Starter Assembly.

END OF TASK

INSTALLATION

1. If removed, install pulley (Figure 1) on engine flywheel with cap screws.
2. Position recoil starter assembly on engine as noted when removed.
3. Install cap screws and check recoil starter assembly for proper operation.

END OF TASK

END OF WORK PACKAGE

FIELD MAINTENANCE**2 kW MEP-501A/531A MILITARY TACTICAL GENERATOR SETS****ENGINE OIL STRAINER: REMOVAL, CLEANING, INSTALLATION**

INITIAL SETUP:**Tools and Special Tools**

Tool Kit, General Mechanic's Automotive or Standard Automotive Tool Set (WP 0159, Table 2, Item 6)

Materials/Parts

Solvent, Cleaning (WP 0162, Table 1, Item 20)

References

WP 0162, Table 1, Item 20

Equipment Condition

Generator set shut down (WP 0005, Stopping Procedure)
Cable disconnected for NATO Slave Receptacle (WP 0005)
Engine Oil drained

WARNING

Cleaning solvents are flammable and toxic to eyes, skin, and respiratory tract. Skin/eye protection required. Avoid repeated/prolonged contact. Good general ventilation is normally adequate.

REMOVAL

1. Shut down diesel engine.

CAUTION

Avoid spilling of oil on ground to prevent environmental contamination. Use chemical resistant gloves for spill cleanup. Cleanup spills if you can do so without hazard to yourself. Collect all cleanup materials, and report/coordinate incident to the local Installation Environmental Office (IEO).

2. Remove oil drain plug and drain lubrication oil into an appropriate chemical resistant container for disposition/disposal through the local servicing Defense Reutilization and Marketing Office (DRMO). Install oil drain plug.
3. Remove capscrew (Figure 1) and oil strainer from crankcase.
4. Remove and discard O-ring from oil strainer.
5. Coordinate disposition/disposal of waste oil with the IEO and DRMO.

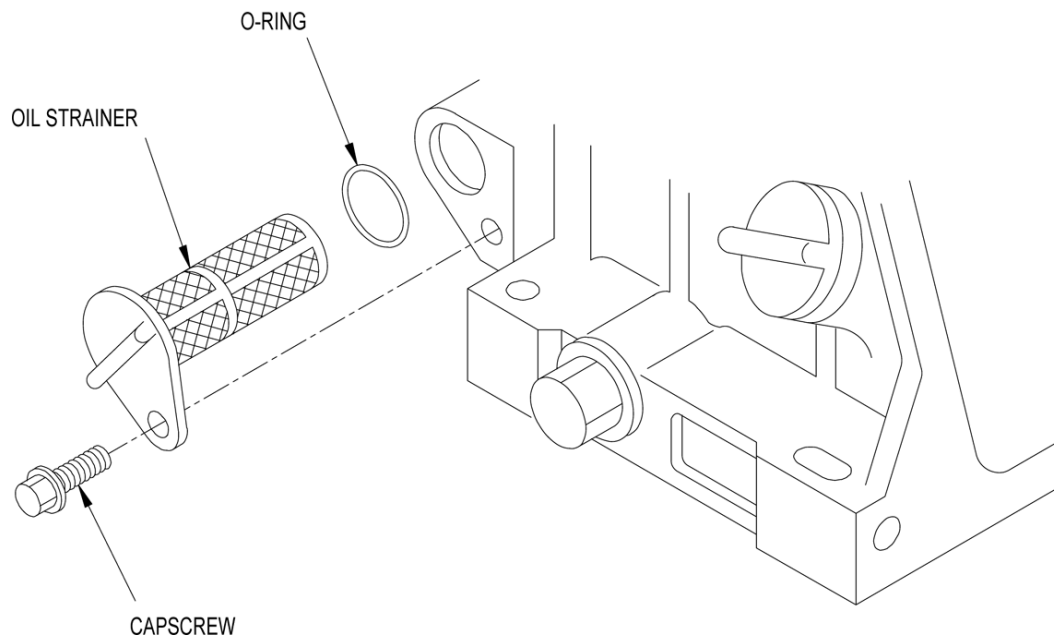

Figure 1. Engine Oil Strainer.

END OF TASK

CLEANING

WARNING

Cleaning solvents are flammable and toxic to eyes, skin, and respiratory tract. Skin/eye protection required. Avoid repeated/prolonged contact. Good general ventilation is normally adequate.

1. Clean oil strainer (Figure 1) in approved solvent (WP 0162, Table 1, Item 20).
2. Inspect oil strainer for torn or crushed mesh, corrosion, and other damage.
3. Replace oil strainer if damaged.

END OF TASK

INSTALLATION

1. Install new O-ring (Figure 1) on engine oil strainer.

CAUTION

Do not reuse the old O-ring.

CAUTION

Ensure O-ring is properly seated (O-ring can be felt "popping" into groove) prior to tightening capscrew.

2. Install oil strainer in crankcase with capscrew (hand tight and 1/8 turn).
3. Service engine lubrication system.

4. Thoroughly wash hands.

END OF TASK

END OF WORK PACKAGE

FIELD MAINTENANCE**2 kW MEP-501A/531A MILITARY TACTICAL GENERATOR SETS****VALVE COVER: REMOVAL, INSPECTION, INSTALLATION**

INITIAL SETUP:**Tools and Special Tools**

Tool Kit, General Mechanic's Automotive or
Standard Automotive Tool Set
(WP 0159, Table 2, Item 6)

Materials/Parts

Valve Cover Gasket
Grounding Equipment

Personnel Required

91D

References

WP 0004, Description and Use of Operator Controls
and Indicators

Equipment Condition

Engine control switch off (WP 0004, Table 1)

REMOVAL

1. Shut down generator set.
2. Remove plunger (Figure 1) from valve cover.
3. Remove bolts, valve cover, and gasket from cylinder head. Discard gasket.

END OF TASK**INSPECTION**

1. Inspect valve cover for cracks, corrosion, and other damage.
2. Replace valve cover if damaged.

END OF TASK**INSTALLATION**

1. Install new gasket (Figure 1) and valve cover on cylinder head with bolts.
2. Install plunger in valve cover.

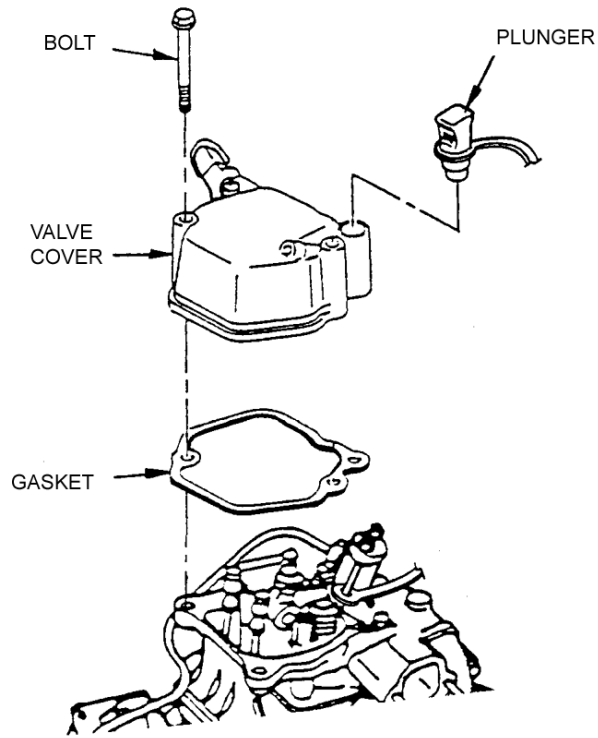

Figure 1. Valve Cover.

END OF TASK

END OF WORK PACKAGE

FIELD MAINTENANCE**2 kW MEP-501A/531A MILITARY TACTICAL GENERATOR SETS
STARTER ASSEMBLY (MEP-501A): REMOVAL, INSTALLATION**

INITIAL SETUP:**Tools and Special Tools**

Tool Kit, General Mechanic's Automotive or
Standard Automotive Tool Set
(WP 0159, Table 2, Item 6)

Materials/Parts

Grounding Equipment

Personnel Required

91D

References

WP 0004, Description and Use of Operator Controls
and Indicators

Equipment Condition

Engine control switch off (WP 0004, Table 1)

REMOVAL

1. Shut down generator set.
2. Tag and disconnect electrical leads from starter assembly (Figure 1).
3. Remove bolts and starter from engine.

END OF TASK**INSTALLATION**

1. Install starter assembly (Figure 1) on engine with bolts.
2. Connect electrical leads and remove tags.
3. Check starter assembly for proper operation.

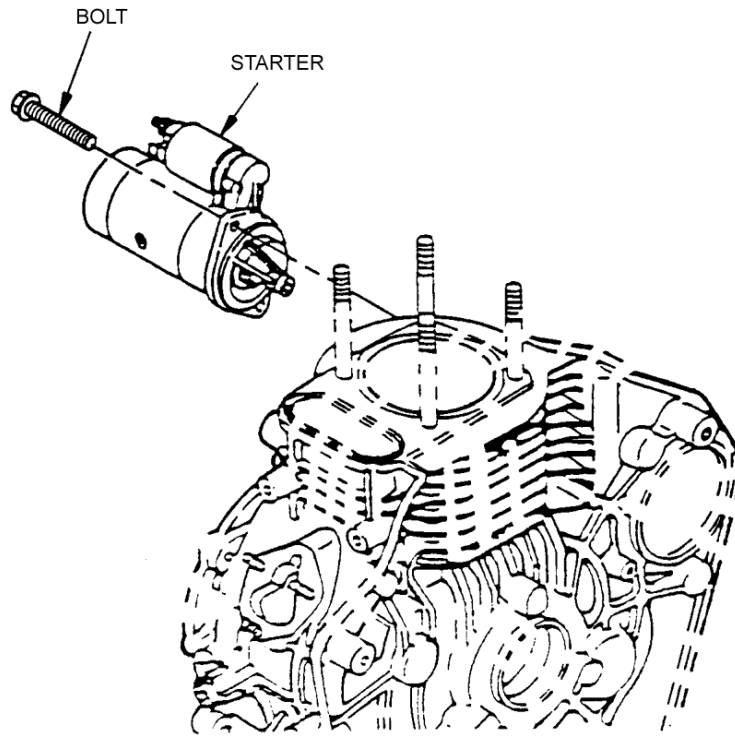

Figure 1. Starter Assembly.

END OF TASK

END OF WORK PACKAGE

FIELD MAINTENANCE**2 kW MEP-501A/531A MILITARY TACTICAL GENERATOR SETS****ENGINE WIRING HARNESS: INSPECTION, REMOVAL, DISASSEMBLY, REPAIR, INSTALLATION**

INITIAL SETUP:**Tools and Special Tools**

Tool Kit, General Mechanic's Automotive or Standard Automotive Tool Set (WP 0159, Table 2, Item 6)
Multimeter (WP 0159, Table 2, Item 3)

Materials/Parts

Grounding Equipment

Personnel Required

91D

References

WP 0004, Description and Use of Operator Controls and Indicators

Equipment Condition

Engine control switch off (WP 0004, Table 1)

INSPECTION

1. Shut down generator set.
2. Visually inspect engine-wiring harness wiring for cracked or deteriorated insulation, broken terminals, and other damage.
3. Visually inspect the engine wiring harness receptacle for security, cracks, broken wires, and other damage.

END OF TASK**REMOVAL**

1. Shut down generator set.
2. Disconnect engine wiring harness plug (P2) (Figure 1) from receptacle on bottom of control panel.
3. Set multimeter for ohms and check for continuity between P2 socket A and stud on air intake preheater (HTR2), P2 socket B and LOP switch (S1), P2 socket C and starter solenoid switch (L5) pin C, P2 socket D and starter solenoid switch (L5) pin S, P2 socket E and diesel engine dynamo, and P2 socket F and diesel engine dynamo.
4. If necessary, repair wiring harness. Then connect plug to receptacle on bottom of control panel.

END OF TASK**DISASSEMBLY**

1. Shut down generator set.
2. Disconnect engine wiring harness plug (Figure 1) from receptacle on bottom of control panel.
3. Tag and disconnect wiring harness leads at air intake heating elements, LOP switch, starter solenoid switch (2 places), and diesel engine dynamo (2 places).
4. Cut cable ties as necessary and remove engine wiring harness.

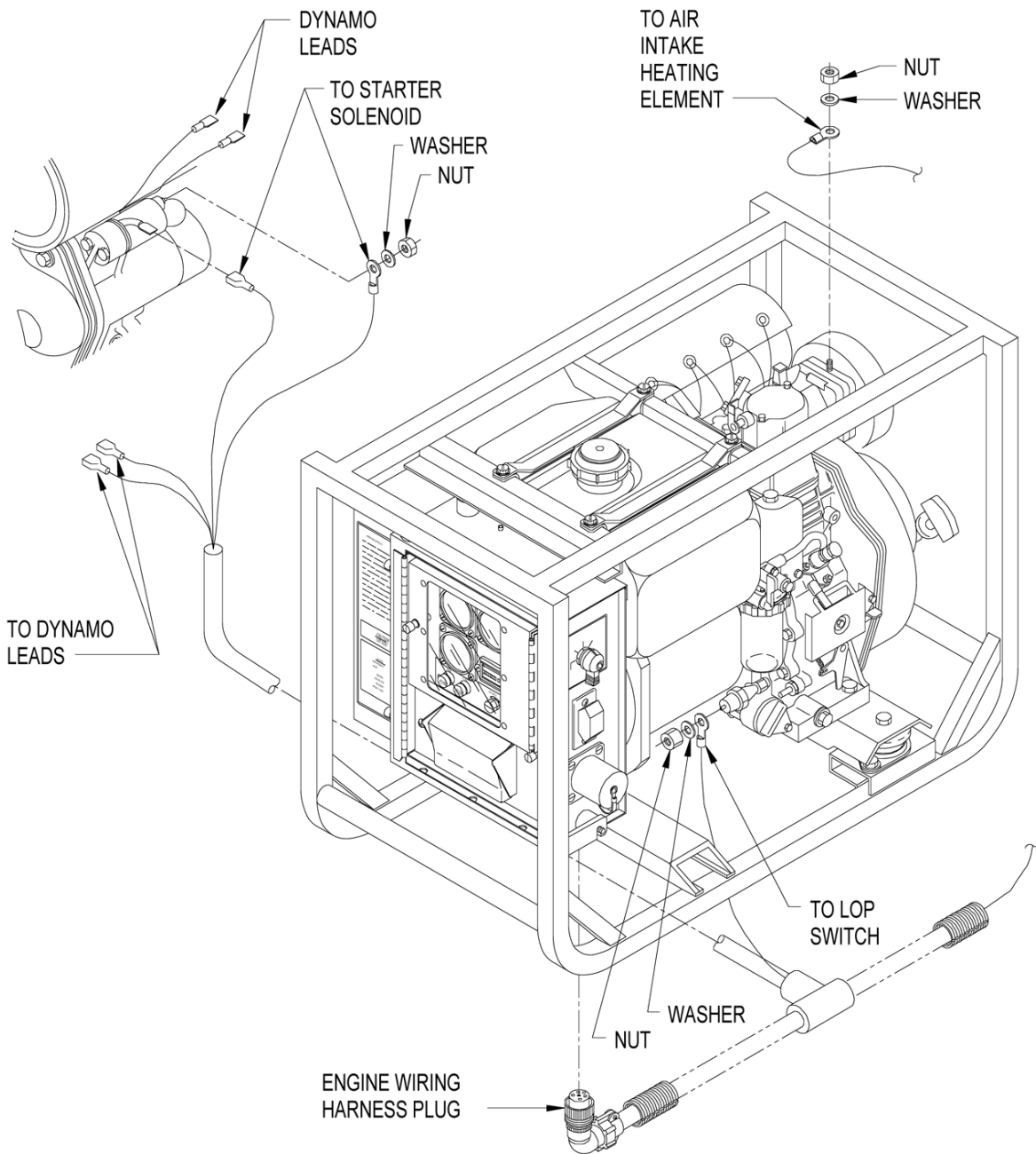

Figure 1. Engine Wiring Harness.

END OF TASK

REPAIR

1. Cut cable ties and flexible tubing as necessary.
2. If replacing individual wires and/or connectors, tag and remove defective wires. Then install new cable ties and tape flexible tubing as necessary and remove tags.

END OF TASK

INSTALLATION

1. Route engine wiring harness (Figure 1) as removed. Use new cable ties to secure harness where required.
2. Connect engine wiring harness as tagged. Remove tags.
3. Connect engine wiring harness plug to receptacle on bottom of control panel.

END OF TASK**END OF WORK PACKAGE**

FIELD MAINTENANCE**2 kW MEP-501A/531A MILITARY TACTICAL GENERATOR SETS****ALTERNATOR WIRING HARNESS (MEP-501A): INSPECTION, TESTING, REMOVAL, REPAIR,
INSTALLATION**

INITIAL SETUP:**Tools and Special Tools**

Tool Kit, General Mechanic's Automotive or
Standard Automotive Tool Set
(WP 0159, Table 2, Item 6)
Multimeter (WP 0159, Table 2, Item 3)

Materials/Parts

Grounding Equipment

Personnel Required

91D

References

WP 0004, Description and Use of Operator Controls
and Indicators
WP 0111, Wiring Harness, Alternator (P/N: 95-8028)

Equipment Condition

Engine control switch off (WP 0004, Table 1)

INSPECTION

1. Shut down generator set.
2. Visually inspect alternator wiring harness wiring for cracked or deteriorated insulation, broken terminals, and other damage.
3. Visually inspect the alternator wiring harness receptacle for security, cracks, broken wires, and other damage.

END OF TASK**TESTING**

1. Shut down generator set.
2. Disconnect alternator wiring harness plug (P1) (Figure 1) from receptacle on bottom of control panel.
3. Set multimeter for ohms and check for continuity between P1 socket A and alternator (G2) pin +, P1 socket B and alternator (G2) pin FLD, P1 socket D and alternator (G2) pin STA, P1 socket C and alternator (G2) pin -.
4. If necessary, repair wiring harness. Then connect plug to receptacle on bottom of control panel.

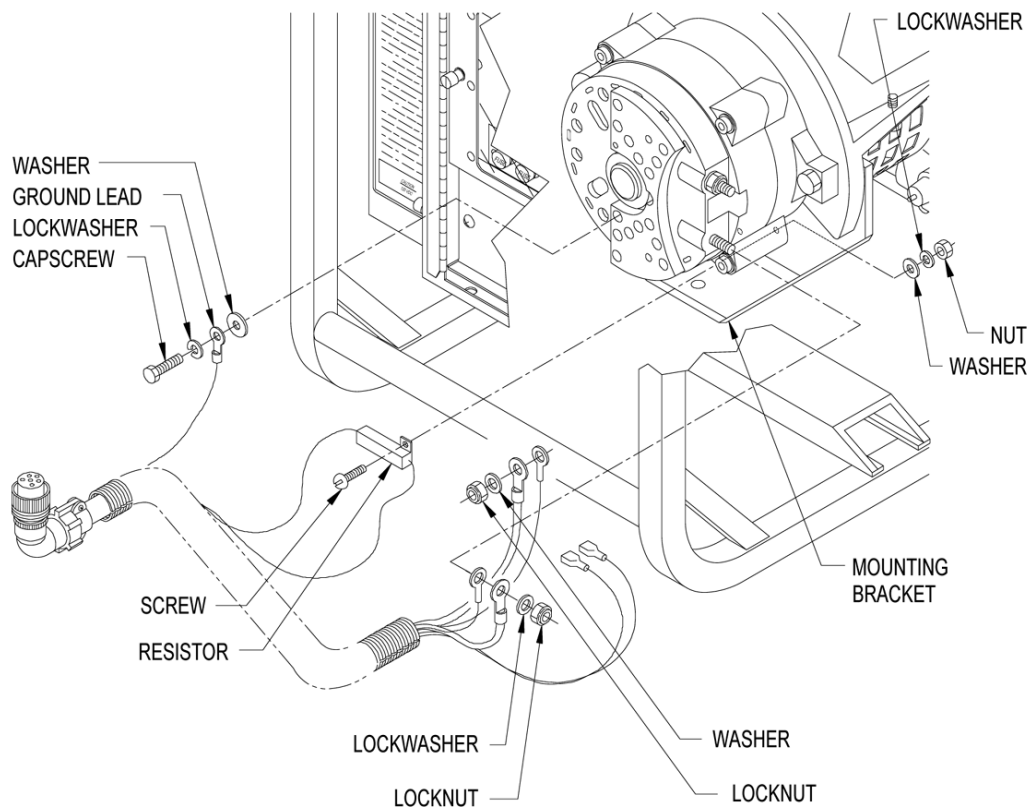

Figure 1. Alternator Wiring Harness.

END OF TASK

REMOVAL

1. Shut down generator set.
2. Disconnect alternator wiring harness plug (Figure 1) from receptacle on bottom of control panel.
3. Remove capscrews, screws, lockwashers, washers and nut securing wiring harness ground lead to alternator and wiring harness resistor to mounting bracket.
4. Tag and disconnect wiring harness leads at alternator at four places.
5. Cut cable ties as necessary and remove generator wiring harness.

END OF TASK

REPAIR

1. Cut cable ties and flexible tubing as necessary.
2. If replacing individual wires and/or connectors, tag and remove defective wires. Then install new cable ties and tape flexible tubing as necessary and remove tags.
3. If replacing the entire harness assembly, make new harness in accordance with WP 0111.

END OF TASK

INSTALLATION

1. Route alternator wiring harness (Figure 1) as removed. Use new cable ties to secure harness where required.
2. Connect alternator wiring harness as tagged. Remove tags.
3. Connect wiring harness ground lead to alternator and attach wiring harness resistor to mounting bracket with capscrews, screws, lockwashers, washers, and nut.
4. Connect alternator wiring harness plug to receptacle on bottom of control panel.

END OF TASK**END OF WORK PACKAGE**

FIELD MAINTENANCE**2 kW MEP-501A/531A MILITARY TACTICAL GENERATOR SETS****PREHEATER LEAD: INSPECTION, TESTING, REMOVAL, REPAIR, INSTALLATION**

INITIAL SETUP:**Tools and Special Tools**

Tool Kit, General Mechanic's Automotive or Standard Automotive Tool Set (WP 0159, Table 2, Item 6)

Materials/Parts

Grounding Equipment
Electrical Connector

Personnel Required

91D

References

WP 0004, Description and Use of Operator Controls and Indicators
WP 0110, Preheater Lead, electrical (P/N: 95-8141)

Equipment Condition

Engine control switch off (WP 0004, Table 1)

INSPECTION

1. Shut down generator set.
2. Visually inspect preheater lead for cracked or deteriorated insulation, broken terminals, and other damage.

END OF TASK**TESTING**

1. Shut down generator set.
2. Set multimeter for ohms and check for continuity between air intake heating elements stud and cylinder head bolt connecting preheater lead to ground.
3. If necessary, repair preheater lead.

END OF TASK**REMOVAL**

1. Shut down generator set.
2. Remove nut (Figure 1) and disconnect preheater lead at stud on air intake heating elements. Then remove bolt, washer, and lockwasher securing other terminal of preheater lead to diesel engine.
3. Cut tie wraps as necessary and remove preheater lead.

END OF TASK**REPAIR**

Replace individual connectors or assemble complete preheater lead in accordance with WP 0110.

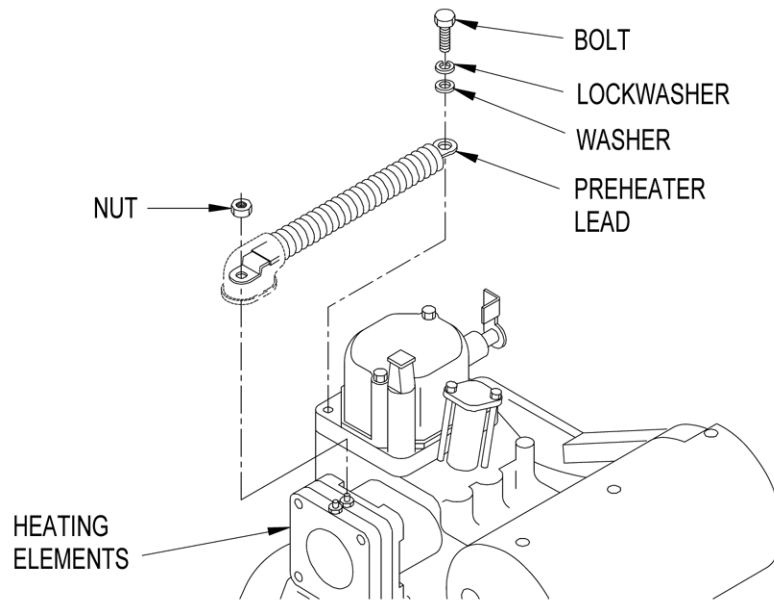

Figure 1. Preheater Lead.

END OF TASK

INSTALLATION

1. Route preheater lead (Figure 1) as removed. Use new cable ties to secure lead where required.
2. Connect preheater lead at air intake heating elements stud with nut. Then connect other end to engine with bolt, lockwasher, and washer.

END OF TASK

END OF WORK PACKAGE

FIELD MAINTENANCE**2 kW MEP-501A/531A MILITARY TACTICAL GENERATOR SETS**
GROUND STUD TERMINAL: INSPECTION, REMOVAL, INSTALLATION

INITIAL SETUP:**Tools and Special Tools**

Tool Kit, General Mechanic's Automotive or Standard Automotive Tool Set (WP 0159, Table 2, Item 6)

Materials/Parts

Grounding Equipment
Corrosion Preventive Compound (WP 0162, Table 1, Item 5)
Insulating Electrical Compound (WP 0162, Table 1, Item 6)

Personnel Required

91D

References

WP 0004, Description and Use of Operator Controls and Indicators
WP 0162, Table 1, Item 5, and 6

Equipment Condition

Engine control switch off (WP 0004, Table 1)

INSPECTION

1. Shut down generator set.
2. Inspect the ground stud terminal for deformed threads, corrosion, or other physical damage.
3. Ensure that the connections to the terminal are clean and tight. Replace if defective.

END OF TASK**REMOVAL**

1. Shut down generator set.
2. Disconnect ground wire from ground stud terminal (Figure 1) as necessary.
3. Hold terminal body hex with wrench and remove locknut, washer, and ground stud terminal from generator set frame.

END OF TASK**INSTALLATION****CAUTION**

Ground stud terminal shears off easily if locknut is over-tightened. Do not over-torque locknut.

1. Apply corrosion preventive compound (WP 0162, Table 1, Item 5) on frame contact points and install ground stud terminal (Figure 1) in generator set frame with washer and locknut. Hold terminal body hex with wrench. Torque locknut to 35 in•lb. (3.95 N•m) from bottom. Apply insulating electrical compound (WP 0162, Table 1, Item 6) to threads of locknut prior to assembly.
2. Connect ground wire to ground stud terminal as necessary.

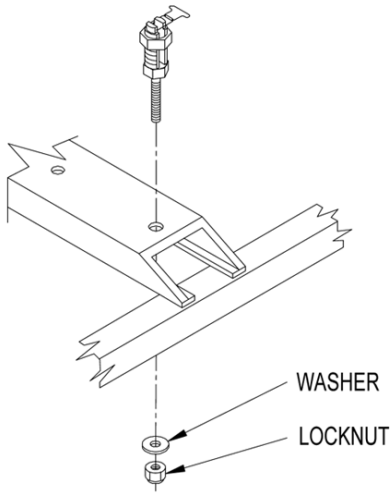

Figure 1. Ground Stud Terminal.

END OF TASK

END OF WORK PACKAGE

FIELD MAINTENANCE**2 kW MEP-501A/531A MILITARY TACTICAL GENERATOR SETS****GENERATOR CONTROL UNIT: INSPECTION, TESTING, REMOVAL, INSTALLATION**

INITIAL SETUP:**Tools and Special Tools**

Tool Kit, General Mechanic's Automotive or Standard Automotive Tool Set (WP 0159, Table 2, Item 6)
Multimeter (WP 0159, Table 2, Item 3)

Materials/Parts

As required

References

WP 0059, Electromagnetic Interference (EMI) filter (MEP-531A)
WP 0088, Dynamo
WP 0096, Dewey/Mechron Cross-Reference List

Equipment Condition

Generator set shut down (WP 0005, Stopping Procedure)
Cable disconnected for NATO Slave Receptacle (WP 0005)

WARNING

Never attempt to start the generator set if it is not properly grounded. Failure to observe this warning could result in serious injury or death by electrocution.

WARNING

High voltage is produced when this generator set is in operation. Use care when working around an open control panel with the generator set operating. Improper operation and/or failure to follow this warning could result in personal injury or death by electrocution.

NOTE

For generator sets manufactured by Mechron, wiring and component labeling differences exist between the text in this manual and the generator sets. Cross-Reference tables and wiring diagrams are provided in WP 0096, Table 1 - Dewey/Mechron Cross-Reference List, and in fold-out sheets after Alphabetical Index.

INSPECTION

1. Shut down generator set.
2. Release instrument panel by turning fastener. Open instrument panel slowly.
3. Visually inspect the generator control unit for security, cracks, broken wires, corrosion, and other damage.
4. Close and secure instrument panel.

END OF TASK**TESTING MEP-531A**

1. Shut down generator set.
2. Release instrument panel by turning fastener. Open instrument panel slowly.

WARNING

High voltage is produced when this generator set is in operation. Use care when working around an open control panel with the generator set operating. Improper operation and/or failure to follow this warning could result in personal injury or death by electrocution.

3. Start generator set.
4. Set multimeter to AC volts and connect positive lead of multimeter to terminal 5 on terminal board TB1 and negative lead to terminal 6 of TB1. Multimeter should indicate 40-50 VAC. If reading is low, dynamo is defective. Replace Dynamo, refer to WP 0088, Removal. If there is no voltage, check diesel engine dynamo (G1) and wiring between dynamo and TB1, refer to WP 0088, Testing. Then redo Step 4.
5. Connect positive lead of multimeter to terminal 10 of TB1 and negative lead to terminal 1 of TB1. Multimeter should indicate 119-121 VAC. If reading is incorrect, check wiring between CB1-A (Line) and TB1. Then redo Step 5.
6. Set multimeter for DC volts and connect positive lead of multimeter to terminal 2 of TB1 and negative lead to terminal 1 of TB1. Multimeter should indicate 35-45 VDC.
7. Connect positive lead of multimeter to terminal 4 of TB1 and negative lead to terminal 1 of TB1. Multimeter should indicate 35-45 VDC. If reading is incorrect, check LOP solenoid (L4) and wiring between solenoid and TB1. Then redo Step 7.
8. Connect positive lead of multimeter to terminal 3 of TB1 and negative lead to terminal 1 of TB1. Multimeter should indicate 18-22 VDC.
9. Connect positive lead of multimeter to terminal 7 of TB1 and negative lead to terminal 1 of TB1. Multimeter should indicate 0-2 VDC with ON-OFF load circuit breaker CB1 in OFF position. With CB1 in ON position, multimeter should indicate 35-45 VDC.
10. Apply a ground to LOP switch terminal. Diesel engine should stop.

CAUTION

The following steps are the only way to check the short circuit function of the generator control unit without special test equipment. If the ON-OFF load circuit breaker closes and does not open instantaneously, IMMEDIATELY open it manually. Electrical circuitry and component damage could occur in less than a second if short circuit function is inoperative.

11. With diesel engine stopped, connect a piece of 18 AWG electrical wire across output load terminals. Loop wire so as to avoid contact with the generator set frame.
12. Start diesel engine and attempt to close ON-OFF load circuit breaker. The circuit breaker should open instantaneously.
13. Shutdown engine and remove cable from output load terminals.
14. Replace generator control unit if any of the above readings are not as stated.
15. Close and secure instrument panel.

END OF TASK

TESTING MEP-501A

1. Shut down generator set.
2. Release instrument panel by turning fastener. Open instrument panel slowly.

WARNING

High voltage is produced when this generator set is in operation. Use care when working around an open control panel with the generator set operating. Improper operation and/or failure to follow this warning could result in personal injury or death by electrocution.

3. Start generator set.
4. Set multimeter to AC volts and connect positive lead of multimeter to terminal 6 on terminal board TB1 and negative lead to terminal 7 of TB1. Multimeter should indicate 40-50 VAC. If reading is incorrect, check diesel engine dynamo (G1) and wiring between dynamo and TB1. Then redo Step 4.
5. Set multimeter for DC volts and connect positive lead of multimeter to terminal 9 of TB1 and negative lead to terminal 1 of TB1. Multimeter should indicate 27-29 VDC. If reading is incorrect, check wiring between CB1-P1 (Line) and TB1. Then redo Step 5.

6. Connect positive lead of multimeter to terminal 3 of TB1 and negative lead to terminal 1 of TB1. Multimeter should indicate 35-45 VDC.
7. Connect positive lead of multimeter to terminal 5 of TB1 and negative lead to terminal 1 of TB1. Multimeter should indicate 35-45 VDC. If reading is incorrect, check LOP solenoid (L4) and wiring between solenoid and TB1. Then redo Step 7.
8. Connect positive lead of multimeter to terminal 4 of TB1 and negative lead to terminal 1 of TB1. Multimeter should indicate 18-22 VDC.
9. Connect positive lead of multimeter to terminal 8 of TB1 and negative lead to terminal 1 of TB1. Multimeter should indicate 0-1 VDC with ON-OFF load circuit breaker CB1 in OFF position. With CB1 in ON position, multimeter should indicate 35-45 VDC.

NOTE

At generator set startup, generator control (A2) momentarily applies current to field flash the alternator (G2). It can therefore be assumed that if the alternator is producing power, this function of A2 is satisfactory. However, if it is suspected that there is no field flash current for the alternator (G2), check A2 as follows.

10. Shutdown diesel engine. Disconnect A2-VINDC at terminal 9 of TB1 and A2-F at terminal 10 of TB1. Connect positive lead of multimeter to disconnected A2-F wire and negative lead to terminal 1 of TB1. Then start diesel engine. Multimeter should indicate 35-45 VDC. Shutdown diesel engine and reconnect wires to terminals 9 and 10 of TB1.
11. Start generator set.
12. Apply a ground to LOP switch terminal. Diesel engine should stop.

CAUTION

The following steps are the only way to check the short circuit function of the generator control unit without special test equipment. If the ON-OFF load circuit breaker closes and does not open instantaneously, IMMEDIATELY open it manually. Electrical circuitry and component damage could occur in less than a second if short circuit function is inoperative.

13. With diesel engine stopped, connect a piece of 4 AWG electrical wire across output load terminals. Loop wire so as to avoid contact with the generator set frame.
14. Start diesel engine and attempt to close ON-OFF load circuit breaker. The circuit breaker should open instantaneously.
15. Shutdown engine and remove cable from output load terminals.
16. Replace generator control unit if any of above readings are not as stated.
17. Close and secure instrument panel.

END OF TASK

REMOVAL

1. Shut down generator set.
2. Release instrument panel by turning fastener. Open instrument panel slowly.
3. Remove EMI filter (MEP-531A), refer to WP 0059, Removal.
4. Tag and disconnect electrical leads for generator control unit (Figure 1) from terminals on terminal board TB1.
5. Remove screws, lockwashers, washers, and generator control unit from control panel.

END OF TASK

INSTALLATION

1. Install generator control unit in control panel with washers, lockwashers, and screws.

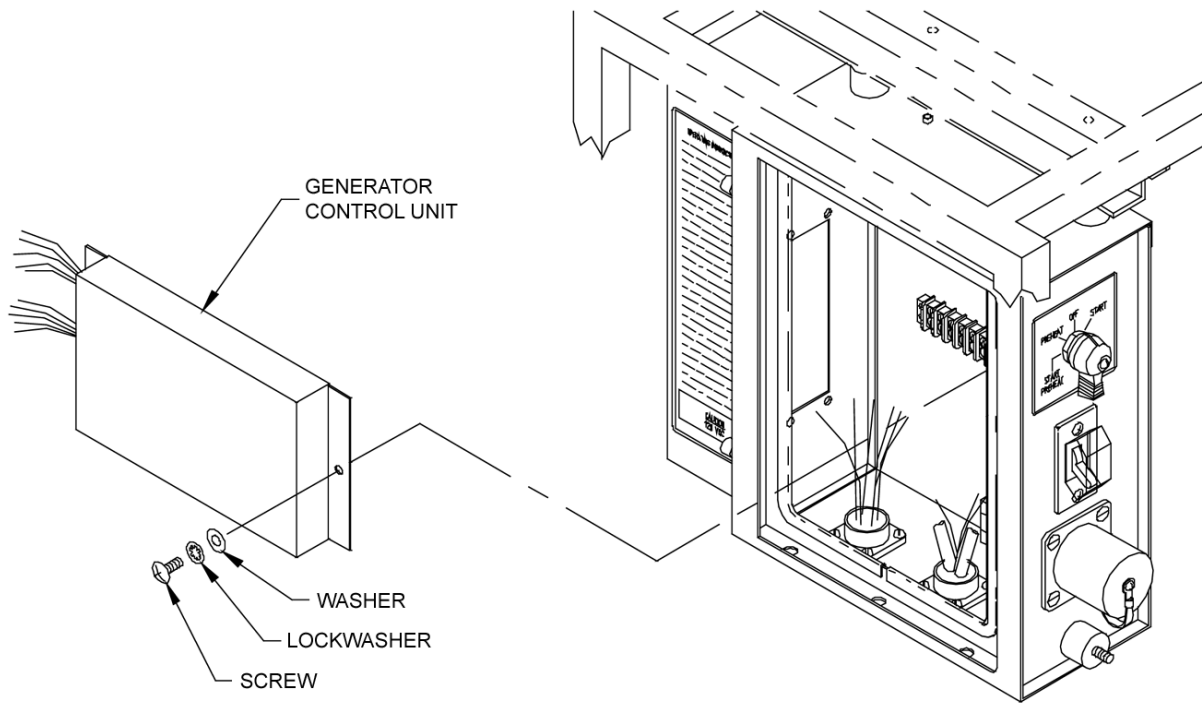

Figure 1. Generator Control Unit (MEP-531A).

2. Connect electrical leads and remove tags.
3. Install EMI filter (MEP-531A), refer to WP 0059, Installation.
4. Close and secure instrument panel.

END OF TASK

END OF WORK PACKAGE

FIELD MAINTENANCE**2 kW MEP-501A/531A MILITARY TACTICAL GENERATOR SETS****VOLTAGE REGULATOR ASSEMBLY: INSPECTION, TESTING, REMOVAL, INSTALLATION**

INITIAL SETUP:**Tools and Special Tools**

Tool Kit, General Mechanic's Automotive or
Standard Automotive Tool Set
(WP 0159, Table 2, Item 6)
Multimeter (WP 0159, Table 2, Item 3)

Materials/Parts

As required

Equipment Condition

Generator set shut down (WP 0005, Stopping
Procedure)
Cable disconnected for NATO Slave Receptacle
(WP 0005)

WARNING

High voltage is produced when this generator set is in operation. Use care when working around an open control panel with the generator set operating. Improper operation and/or failure to follow this warning could result in personal injury or death by electrocution.

WARNING

Never attempt to start the generator set if it is not properly grounded. Failure to observe this warning could result in serious injury or death by electrocution.

INSPECTION

1. Shut down generator set.
2. Release instrument panel by turning fastener. Open instrument panel slowly.
3. Inspect voltage regulator for security, cracked case, corrosion, and other damage.
4. Close and secure instrument panel.

END OF TASK**TESTING MEP-531A**

1. Shut down generator set.
2. Connect load bank to load terminals.
3. Release instrument panel by turning fastener. Open instrument panel slowly.

WARNING

High voltage is produced when this generator set is in operation. Use care when working around an open control panel with the generator set operating. Improper operation and/or failure to follow this warning could result in personal injury or death by electrocution.

4. Start generator set and turn VOLTAGE ADJ. potentiometer to verify adjustment range (114 to 126 VAC). If no voltage or low voltage was indicated, or voltage adjustment range could not be achieved, continue with the following steps. Otherwise, voltage regulator is serviceable.

5. Test VOLTAGE ADJ. potentiometer, refer to WP 0040, Testing. If defective, replace VOLTAGE ADJ. potentiometer and redo Step 4.
6. Set multimeter for AC volts and connect positive lead of multimeter to terminal 13 of TB1 and negative lead to terminal 15 of TB1. Multimeter should indicate approximately 114-126 VAC.
7. Connect positive lead of multimeter to terminal 8 of TB1 and negative lead to terminal 15 of TB1. Multimeter should indicate 160-180 VAC. If reading is incorrect, check alternator G2, WP 0089, Testing (Alternator Installed), and wiring between G2 and TB1. If defective, repair/replace alternator and/or wiring. Then redo Step 4.
8. With positive lead of multimeter connected to terminal 8 on TB1, move negative lead to terminal 9 of TB1. Place ON-OFF load circuit breaker CB1 to ON. Then using load bank, apply a load. Multimeter should indicate an increase until load stabilizes. If there is no increase, voltage regulator is defective.
9. Shut down generator set and disconnect load bank.
10. Replace voltage regulator if any of above readings are not as stated.
11. Close and secure instrument panel.

END OF TASK

TESTING MEP-501A

1. Shut down generator set.
2. Connect load bank to load terminals.
3. Release instrument panel by turning fastener. Open instrument panel slowly.

WARNING

High voltage is produced when this generator set is in operation. Use care when working around an open control panel with the generator set operating. Improper operation and/or failure to follow this warning could result in personal injury or death by electrocution.

4. Start generator set and turn VOLTAGE ADJ. potentiometer to verify adjustment range (26.6 to 32.2 VDC). If no voltage or low voltage was indicated on VOLTS DC meter, or voltage adjustment range could not be achieved, continue with the following steps. Otherwise, voltage regulator is serviceable.
5. Test VOLTAGE ADJ. potentiometer, refer to WP 0040, Testing. If defective, replace VOLTAGE ADJ. potentiometer and redo Step 4.
6. Set multimeter for DC volts and connect positive lead of multimeter to terminal 9 of TB1 and negative lead to terminal 2 of TB1. Multimeter should indicate approximately 26.6 to 32.2 VDC.
7. Set multimeter to DC volts and connect positive lead of multimeter to terminal 11 of TB1 and negative lead to terminal 2 of TB1. Multimeter should indicate 12-16 VDC. If reading is incorrect, check alternator G2, WP 0091, Testing, and wiring between G2 and TB1. If defective, repair/replace alternator and/or wiring. Then redo Step 4.
8. Connect positive lead of multimeter to terminal 10 on TB1 and negative lead to terminal 2 of TB1. Place ON-OFF load circuit breaker CB1 to ON. Then using load bank, apply a load. Multimeter should indicate an increase until load stabilizes. If no change is indicated, voltage regulator is defective.
9. Shut down generator set.
10. Replace voltage regulator if any of above readings are not as stated.
11. Close and secure instrument panel.

END OF TASK

REMOVAL

1. Shut down generator set.
2. Release instrument panel by turning fastener. Open instrument panel slowly.

3. Tag and disconnect electrical leads for voltage regulator (Figure 1) from terminals of terminal board TB1.
4. Remove screws, lockwashers, washers, and voltage regulator from control panel.

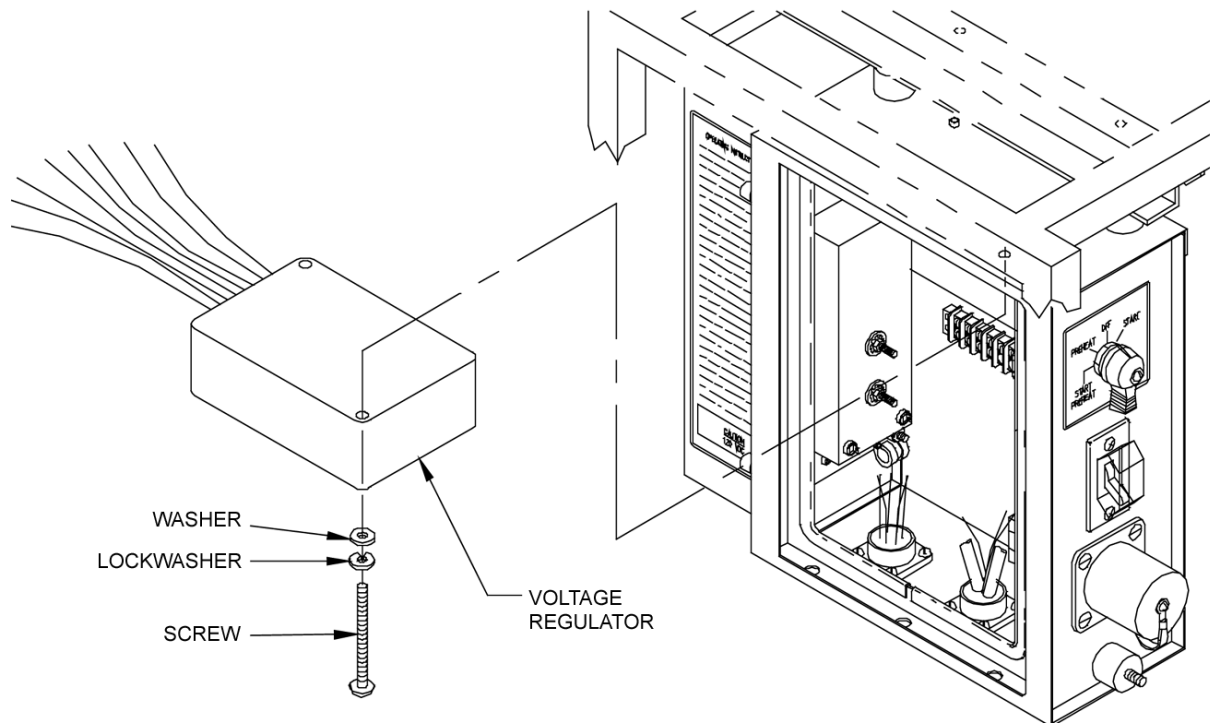

Figure 1. Voltage Regulator Assembly (MEP-531A).

END OF TASK

INSTALLATION

1. Install voltage regulator in control panel with washers, lockwashers, and screws.
2. Connect electrical leads to terminal board TB1 and remove tags.
3. Close and secure instrument panel.

END OF TASK

END OF WORK PACKAGE

FIELD MAINTENANCE**2 kW MEP-501A/531A MILITARY TACTICAL GENERATOR SETS
DIESEL ENGINE WIRING HARNESS, CONTROL PANEL: TESTING, REPAIR**

INITIAL SETUP:**Tools and Special Tools**

Tool Kit, General Mechanic's Automotive or Standard Automotive Tool Set (WP 0159, Table 2, Item 6)
Multimeter (WP 0159, Table 2, Item 3)

Materials/Parts

As required

References

WP 0055, Diesel engine Wiring Harness and Gasket, control Panel, Control Panel
WP 0104, Wiring Harness, Control Panel (P/N:95-8084)
WP 0105, Wiring Harness, Control Panel (P/N: 95-8023)

Equipment Condition

Generator set shut down (WP 0005, Stopping Procedure)
Cable disconnected for NATO Slave Receptacle (WP 0005)

TESTING

1. Shut down generator set.
2. Release instrument panel by turning fastener. Open instrument panel slowly.
3. Disconnect harness, refer to WP 0055, Removal.
4. (MEP-531A). Set multimeter for ohms and check for continuity between J2 pin A and START-PREHEAT/PREHEAT/OFF/START rotary switch (S2) pin H, J2 pin B and TB1 connector 3, J2 pin C and S2 pin S, J2 pin D and NATO slave receptacle (SR1) pin +, J2 pin E and TB1 connector 5, and J2 pin F and TB1 connector 6.
5. (MEP-501A). Set multimeter for ohms and check for continuity between J2 pin A and PREHEAT-START-PREHEAT/PREHEAT/OFF/START rotary switch (S2) pin H, J2 pin B and TB1 connector 4, J2 pin C and S2 pin S, J2 pin D and NATO slave receptacle (SR1) pin +, J2 pin E and TB1 connector 6, and J2 pin F and TB1 connector 7.
6. Reconnect harness, refer to WP 0055, Repair.
7. Close and secure instrument panel.

END OF TASK**REPAIR**

1. Remove diesel engine wiring harness, control panel in accordance with WP 0055, Removal.
2. Repair diesel engine wiring harness, control panel by assembling wire, connector (J2), terminals, splices, insulation, and tiedown straps in accordance with WP 0104, Figure 1 (MEP-531A) or WP 0105, Figure 1 (MEP-501A).
3. Install diesel engine wiring harness, control panel in accordance with WP 0055, Installation.

END OF TASK**END OF WORK PACKAGE**

FIELD MAINTENANCE**2 kW MEP-501A/531A MILITARY TACTICAL GENERATOR SETS
ALTERNATOR WIRING HARNESS, CONTROL PANEL: TESTING, REPAIR**

INITIAL SETUP:**Tools and Special Tools**

Tool Kit, General Mechanic's Automotive or Standard Automotive Tool Set (WP 0159, Table 2, Item 6)
Multimeter (WP 0159, Table 2, Item 3)

Materials/Parts

As required

References

WP 0056, Alternator Wiring Harness and Gasket, Control Panel
WP 0106, Wiring Harness, Control Panel (P/N:95-8075)
WP 0107, Wiring Harness, Control Panel (P/N: 95-8022)

Equipment Condition

Generator set shut down (WP 0005, Stopping Procedure)
Cable disconnected for NATO Slave Receptacle (WP 0005)

TESTING

1. Shut down generator set.
2. Release instrument panel turning fastener. Open instrument panel slowly.
3. Disconnect harness, refer to WP 0056, Removal.
4. (MEP-531A). Set multimeter for ohms and check for continuity between J1 pin A and TB1 connector 13, J1 pin B and EMI filter load terminal lug N, J1 pin C and TB1 connector 14, J1 pin D and TB1 connector 15, J1 pin E and TB1 connector 8, and J1 pin F and TB1 connector 9.
5. (MEP-501A). Set multimeter for ohms and check for continuity between J1 pin A and shunt resistor R3, J1 pin B and TB1 connector 10, J1 pin D and TB1 connector 11, and J1 pin C and load terminal lug-.
6. Reconnect harness, refer to WP 0056, Installation.
7. Close and secure instrument panel.

END OF TASK**REPAIR**

1. Remove alternator wiring harness, control panel in accordance with WP 0056, Removal.
2. Repair alternator wiring harness, control panel by assembling wire, connector (J1), terminals, insulation, and tie down straps in accordance with WP 0106, Figure 1 (MEP-531A) or WP 0107, Figure 1 (MEP-501A).
3. Install alternator wiring harness, control panel in accordance with WP 0056, Installation.

END OF TASK**END OF WORK PACKAGE**

FIELD MAINTENANCE**2 kW MEP-501A/531A MILITARY TACTICAL GENERATOR SETS
ENGINE/ALTERNATOR ASSEMBLY: REMOVAL, INSTALLATION**

INITIAL SETUP:**Tools and Special Tools**

Tool Kit, General Mechanic's Automotive or Standard Automotive Tool Set (WP 0159, Table 2, Item 6)
Shop Equipment, Automotive Maintenance and Repair, Field Maintenance, Suppl 1 W/O Power (WP 0159, Table 2, Item 4)

Materials/Parts

As required

Equipment Condition

Generator set shut down (WP 0005, Stopping Procedure)
Cable disconnected for NATO Slave Receptacle (WP 0005)
Fuel Tank drained: 1.6 gal (6.1 L) into suitable container

WARNING

The fuels in this generator set are flammable. Do not smoke or use open flames when performing maintenance. Do not service or drain the fuel system while open flames are present. Flames and explosion could result in severe personal injury or death. Use a container or cloth to catch any excess fuel to prevent spilling over engine components. Be sure to properly dispose of diesel fuel and diesel fuel soaked cloths.

WARNING

MEP-531A engine/alternator assembly weighs 100 lbs (45.4 kg). MEP-501A engine/alternator assembly weighs 80 lbs (36.2 kg). Use caution when removing assembly to prevent personal injury.

REMOVAL

1. Shut down generator set.
2. Disconnect LOP engine shutdown cable from engine. Refer to WP 0062, Removal.
3. Disconnect diesel engine wiring harness and alternator wiring harness connectors at bottom of control panel.

WARNING

The fuels in this generator set are flammable. Do not smoke or use open flames when performing maintenance. Do not service or drain the fuel system while open flames are present. Flames and explosion could result in severe personal injury or death. Use a container or cloth to catch any excess fuel to prevent spilling over engine components. Be sure to properly dispose of diesel fuel and diesel fuel soaked cloths.

4. Open drain cock and drain fuel from fuel tank. Close drain cock.
5. Loosen clamp and disconnect fuel supply line to fuel filter at fuel tank.
6. Loosen clamp and disconnect fuel return line from fuel tank.
7. Remove bolt (Figure 1), lockwasher, and washer securing engine ground strap to engine.
8. Remove nuts, lockwashers, washers, and bolts securing engine to mounting bracket.

9. Remove nut and lockwasher securing alternator ground strap to generator set frame.
10. Remove nuts, lockwashers, washers, and bolts securing alternator resilient mount to generator set frame.
11. Remove capscrews (WP 0029, Figure 1, Item 5), lockwashers (6), washers (7), and fuel tank guard (11) from generator set.

WARNING

MEP-531A engine/alternator assembly weighs 100 lbs (45.4 kg). MEP-501A engine/alternator assembly weighs 80 lbs (36.2 kg). Use caution when removing assembly to prevent personal injury.

12. Remove engine/alternator assembly from generator set.

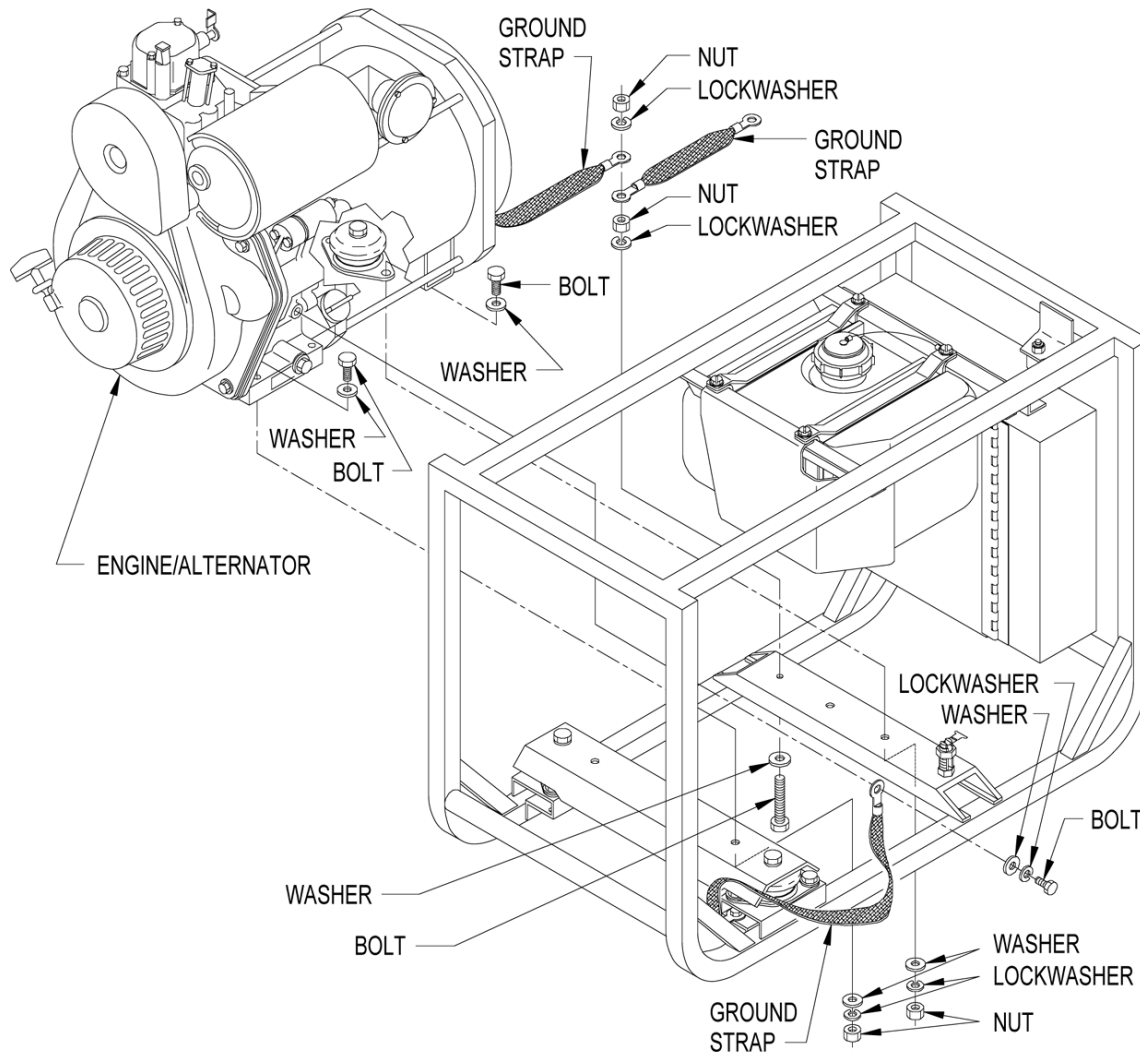

Figure 1. Engine/Alternator Assembly.

END OF TASK

INSTALLATION**WARNING**

MEP-531A engine/alternator assembly weighs 100 lbs (45.4 kg). MEP-501A engine/alternator assembly weighs 80 lbs (36.2 kg). Use caution when removing assembly to prevent personal injury.

1. Position engine/alternator assembly (Figure 1) on generator set frame.
2. Secure alternator resilient mount to generator set frame with bolts, washers, lockwashers, and nuts. Torque nuts to 17 ft•lb.
3. Secure engine to mounting bracket with bolts, washers, lockwashers, and nuts. Torque nuts to 35 ft•lb.
4. Secure alternator ground strap to generator set frame with lockwasher and nut.
5. Attach engine ground strap to engine with washer, lockwasher, and bolt.
6. Install fuel tank guard (WP 0029, Figure 1, Item 11) on generator set with capscrews (5), lockwashers (6), and washers (7).
7. Connect fuel return line to fuel tank. Tighten clamp.
8. Connect fuel supply line to fuel tank. Tighten clamp.
9. Connect and adjust LOP engine shutdown cable to engine. Refer to WP 0062, Installation and Adjustment.
10. Connect diesel engine wiring harness and alternator wiring harness connectors at bottom of control panel.
11. Fill fuel tank with diesel fuel.
12. Prime and bleed the fuel system. Refer to WP 0005, Priming and Bleeding the Fuel System.

END OF TASK**END OF WORK PACKAGE**

FIELD MAINTENANCE**2 kW MEP-501A/531A MILITARY TACTICAL GENERATOR SETS****DIESEL ENGINE: INSTALLATION, REMOVAL**

INITIAL SETUP:**Tools and Special Tools**

Tool Kit, General Mechanic's Automotive or
Standard Automotive Tool Set
(WP 0159, Table 2, Item 6)

Materials/Parts

As required

Equipment Condition

Generator set shut down (WP 0005, Stopping
Procedure)
Cable disconnected for NATO Slave Receptacle
(WP 0005)
Alternator Assembly removed (WP 0088, Dynamo)

REMOVAL**NOTE**

The diesel engine must be broken-in, avoiding heavy loads (no greater than 75%), for a period of twenty (20) hours to ensure proper operation of the generator set. After the initial break-in period, engine lubricating oil must be changed, cylinder head nuts torque must be checked, and intake and exhaust valve clearances must be checked and adjusted. Refer to WP 0083.

1. Remove engine/alternator assembly. Refer to WP 0078, Removal.
2. Remove alternator assembly. Refer to WP 0089, Removal (MEP-531A) or WP 0091, Removal (MEP-501A).
3. If replacing engine, remove the following:
 - a. Engine wiring harness. Refer to WP 0070, Removal.
 - b. LOP switch. Refer to WP 0060, Removal.
 - c. Fuel filter assembly. Refer to WP 0027, Removal.
 - d. Air intake system components. Refer to WP 0030, Removal.
 - e. Air intake heating elements and pipe. Refer to WP 0063, Removal.
 - f. Exhaust system components. Refer to WP 0031, Removal.

END OF TASK**INSTALLATION**

1. If removed, install the following:
 - a. Exhaust system components. Refer to WP 0031, Installation.
 - b. Air intake heating elements and pipe. Refer to WP 0063, Installation.
 - c. Air intake system components. Refer to WP 0030, Installation.
 - d. Fuel filter assembly. Refer to WP 0027, Installation.
 - e. LOP switch. Refer to WP 0060, Installation.
 - f. Engine wiring harness. Refer to WP 0070, Installation.
2. Install alternator assembly. Refer to WP 0089, Installation (MEP-531A) or WP 0091, Installation (MEP-501A).

3. Install engine/alternator assembly. Refer to WP 0078, Installation.

END OF TASK

END OF WORK PACKAGE

FIELD MAINTENANCE

2 kW MEP-501A/531A MILITARY TACTICAL GENERATOR SETS

STARTER (MEP-531A): REMOVAL, INSTALLATION

INITIAL SETUP:

Tools and Special Tools

Tool Kit, General Mechanic's Automotive or Standard Automotive Tool Set (WP 0159, Table 2, Item 6)
Shop Equipment, Automotive Maintenance and Repair, Field Maintenance, Suppl 1 W/O Power (WP 0159, Table 2, Item 4)

Materials/Parts

As required

Equipment Condition

Generator set shut down (WP 0005, Stopping Procedure)
Cable disconnected for NATO Slave Receptacle (WP 0005)

REMOVAL

1. Shut down generator set.
2. Tag and disconnect electrical leads from starter assembly (Figure 1).

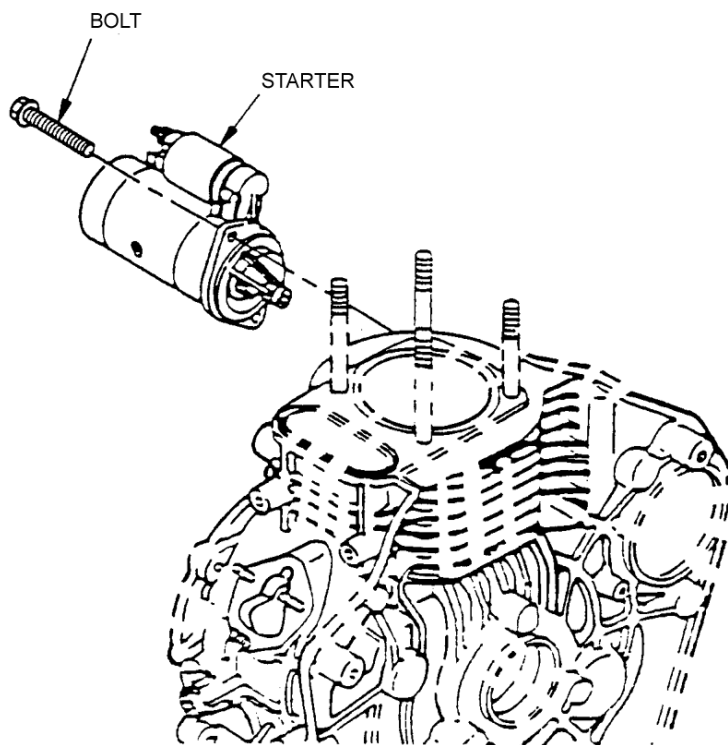

Figure 1. Starter (MEP-531A).

3. Remove AC alternator assembly (MEP-531A), refer to WP 0089, Removal.

4. Remove bolts and starter from engine.

END OF TASK**INSTALLATION**

1. Install starter assembly (Figure 1) on engine with bolts.
2. Install AC alternator assembly (MEP-531A). Refer to WP 0089, Installation.
3. Connect electrical leads and remove tags.
4. Check starter assembly for proper operation.

END OF TASK**END OF WORK PACKAGE**

FIELD MAINTENANCE**2 kW MEP-501A/531A MILITARY TACTICAL GENERATOR SETS**
ROCKER ARMS AND PUSH RODS: REMOVAL, INSPECTION, INSTALLATION

INITIAL SETUP:**Tools and Special Tools**

Tool Kit, General Mechanic's Automotive or Standard Automotive Tool Set (WP 0159, Table 2, Item 6)
Shop Equipment, Automotive Maintenance and Repair, Field Maintenance, Suppl 1 W/O Power (WP 0159, Table 2, Item 4)

Materials/Parts

As required

Equipment Condition

Generator set shut down (WP 0005, Stopping Procedure)
Cable disconnected for NATO Slave Receptacle (WP 0005)

REMOVAL

1. Shut down generator set.
2. Remove valve cover. Refer to WP 0068, Removal.
3. Remove bolt (Figure 1) and support with rocker arms attached.
4. Remove valve inserts from valve stems so they don't get knocked off and lost.
5. Remove intake rocker arm with locknut and adjusting screw from support.
6. Remove exhaust rocker arm with locknut and adjusting screw from support.
7. Remove push rods from cylinder head.
8. If necessary, remove spring pin from cylinder head.

END OF TASK**INSPECTION**

1. Inspect components for nicks, cracks, scoring, corrosion, and other damage.
2. Using a micrometer, measure outside diameter of rocker arm support shafts [0.4685-0.4724 in. (11.9-12.1 mm)].
3. Using a micrometer, measure inside diameter of rocker arms [0.4738-0.4764 in. (12.034-12.1 mm)].
4. Measure push rod length and distortion:
 - a. Length - 5.110-5.126 in. (129.8-130.2 mm)
 - b. Distortion - 0.0020-0.0118 in. (0.05-0.3 mm)
5. Replace defective parts.

END OF TASK**INSTALLATION**

1. If removed, install spring pin (Figure 1) in cylinder head.
2. Insert push rods into cylinder head.
3. Install exhaust rocker arm on support with adjusting screw and locknut.

4. Install intake rocker arm on support with adjusting screw and locknut.
5. Place valve inserts on valve stems.
6. Position support, with rocker arms attached, in cylinder head ensuring spring pin is aligned with hole in support.
7. Secure support in cylinder head with bolt. Torque bolt to 15 -17 ft•lb (20-23 N•m).
8. Adjust valve clearance. Refer to WP 0083.
9. Install valve cover. Refer to WP 0068, Installation.

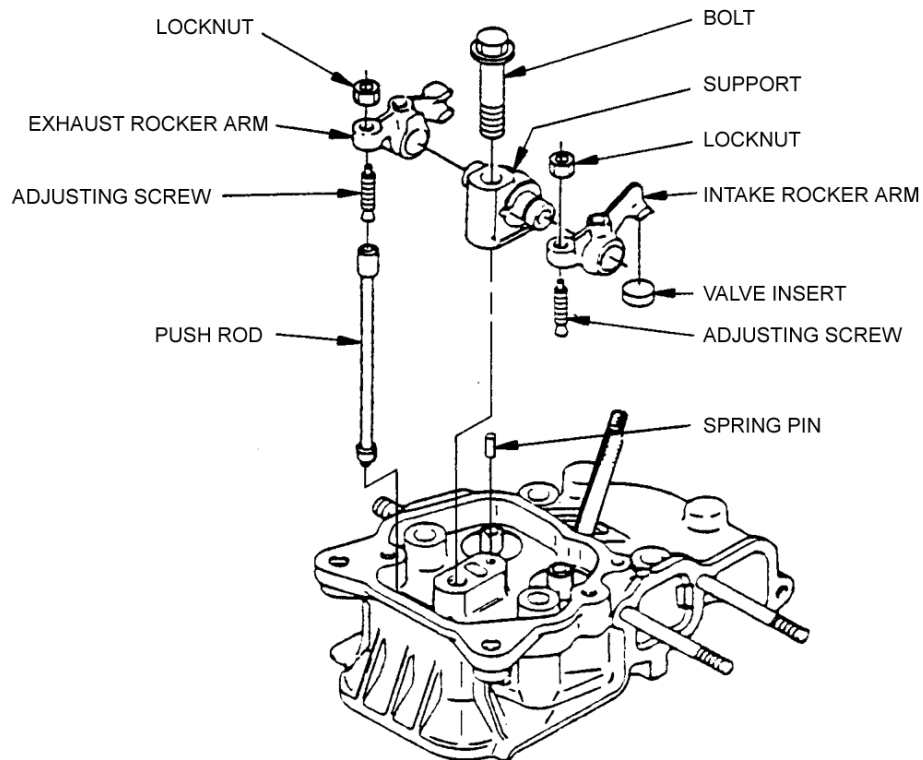

Figure 1. Rocker Arms and Push Rods Assembly.

END OF TASK

END OF WORK PACKAGE

FIELD MAINTENANCE**2 kW MEP-501A/531A MILITARY TACTICAL GENERATOR SETS
CYLINDER HEAD ASSEMBLY: REMOVAL, INSPECTION, INSTALLATION**

INITIAL SETUP:**Tools and Special Tools**

Tool Kit, General Mechanic's Automotive or Standard Automotive Tool Set (WP 0159, Table 2, Item 6)
Shop Equipment, Automotive Maintenance and Repair, Field Maintenance, Suppl 1 W/O Power (WP 0159, Table 2, Item 4)

Materials/Parts

Dye Penetrant (WP 0162, Table 1, Item 9)
Compound, Locking (WP 0163, Table, 1 Item 7)

Equipment Condition

Generator set shut down (WP 0005, Stopping Procedure)
Cable disconnected for NATO Slave Receptacle (WP 0005)

REMOVAL

1. Shut down generator set.
2. Remove air intake system components, refer to WP 0030, Removal.
3. Remove air intake heating elements and pipe, refer to WP 0063, Removal.
4. Remove exhaust system components, refer to WP 0031, Removal.
5. Remove fuel filter assembly, refer to WP 0027, Removal.
6. Remove fuel injector, refer to WP 0019, Removal.
7. Remove valve cover, refer to WP 0068, Removal.
8. Disconnect preheater lead from engine, refer to WP 0072, Removal.
9. Remove nuts (Figure 1), washers, cylinder head, gasket, and O-ring from cylinder block.

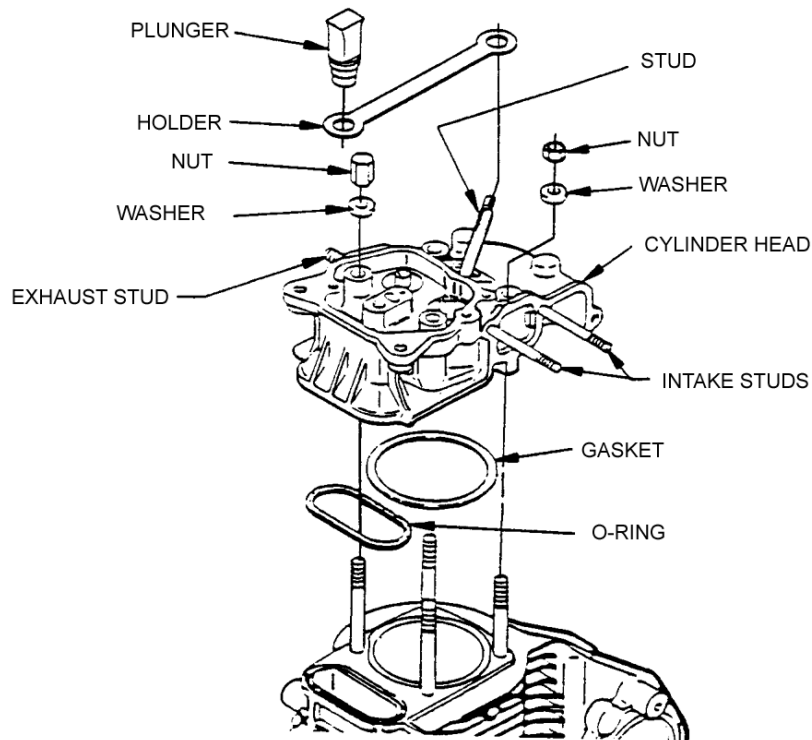

Figure 1. Cylinder Head Assembly.

10. If replacing cylinder head, remove the following:
 - a. Remove plunger and holder from stud.
 - b. Remove all studs.
 - c. Remove valve rocker arm assembly, refer to WP 0081, Removal.
 - d. Remove intake and exhaust valves, refer to WP 0083, Removal.

END OF TASK

INSPECTION

1. Inspect cylinder head for nicks, pitting, corrosion, carbon build-up, and other damage.
2. Using dye penetrant (WP 0162, Table 1, Item 9), check cylinder head for cracks, paying particular attention to areas around valve and fuel injector ports.
3. Replace cylinder head if damaged.

END OF TASK

INSTALLATION

1. If removed, install the following:
 - a. Install intake and exhaust valves, refer to WP 0083, Installation.
 - b. Apply locking compound (WP 0162, Table 1, Item 7) to threads of studs. Install all studs and torque to 5-7 ft•lb (6.8-9.8 N•m) (Figure 1).
 - c. Install plunger and holder.
2. Position O-ring, gasket, and cylinder head on cylinder block.

3. Apply a light coat of lubricating oil (WP 0162, Table 1, Item 15) to threads and seating surfaces of nuts. Install and cross torque nuts to 20-23 ft•lb (27-31 N•m).
4. Install valve rocker arm assembly, refer to WP 0081, Installation.
5. Install valve cover, refer to WP 0068, Installation.
6. Connect preheater lead to engine, refer to WP 0072, Installation.
7. Install fuel injector, refer to WP 0019, Installation.
8. Install fuel filter assembly, refer to WP 0027, Installation.
9. Install exhaust system components, refer to WP 0031, Installation.
10. Install air intake heating elements and pipe, refer to WP 0063, Installation.
11. Install air intake system components, refer to WP 0030, Installation.

END OF TASK

END OF WORK PACKAGE

FIELD MAINTENANCE

2 kW MEP-501A/531A MILITARY TACTICAL GENERATOR SETS

INTAKE AND EXHAUST VALVES: REMOVAL, INSPECTION, INSTALLATION, ADJUSTMENT

INITIAL SETUP:

Tools and Special Tools

Tool Kit, General Mechanic's Automotive or Standard Automotive Tool Set (WP 0159, Table 2, Item 6)
Shop Equipment, Automotive Maintenance and Repair, Field Maintenance, Suppl 1 W/O Power (WP 0159, Table 2, Item 4)

Materials/Parts

Oil Lubricant (WP 0162, Table 1, Item 15)

Equipment Condition

Generator set shut down (WP 0005, Stopping Procedure)
Cable disconnected for NATO Slave Receptacle (WP 0005)

REMOVAL

1. Shut down generator set.
2. Remove cylinder head. Refer to WP 0082, Removal.
3. Using a valve spring compressor, compress valve spring and remove spring lock (Figure 1) and intake valve from cylinder head.

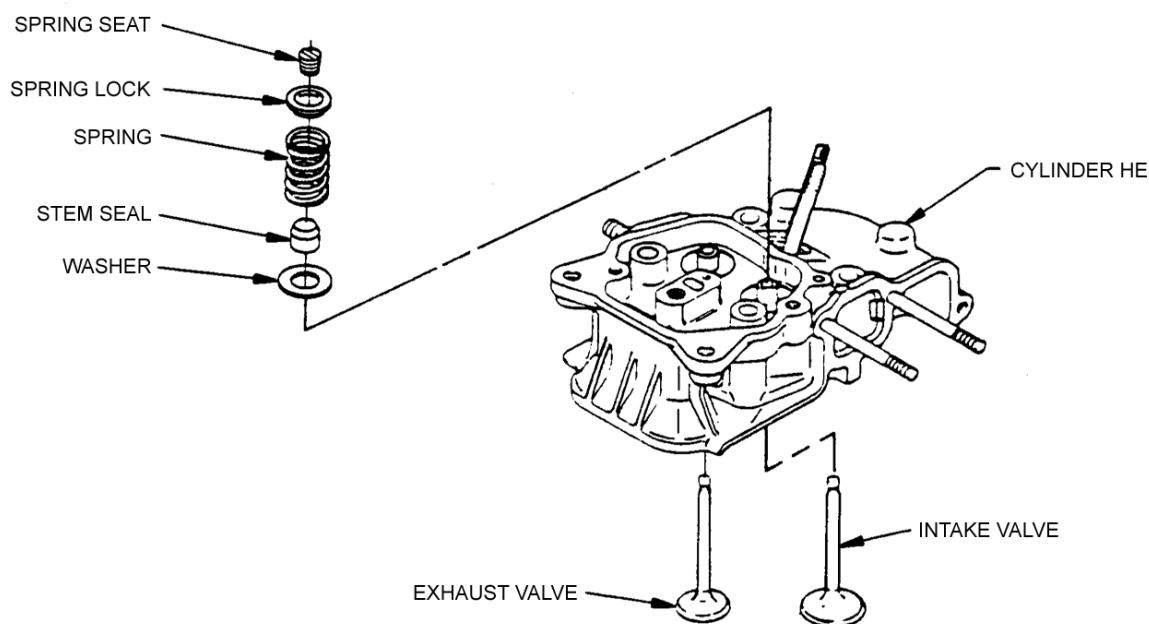

Figure 1. Intake and Exhaust Valves.

4. Slowly release tension on valve spring compressor and remove spring seat, spring, and washer from cylinder head.
5. Remove valve stem seal from cylinder head and discard.

6. Repeat Steps 3 through 5 to remove exhaust valve. Tag valve so as not to confuse exhaust valve with intake valve.

END OF TASK

INSPECTION

1. Clean carbon deposits from components. Check for corrosion and other damage. Replace damaged parts.
2. Measure valve seat angle and width (Figure 2). If out of limits, replace cylinder head.

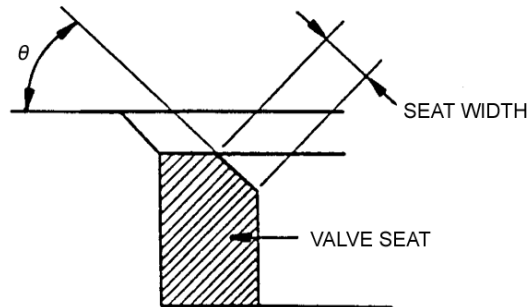

SEAT ANGLE (θ) = 60° - 90°
SEAT WIDTH = 0.059 - 0.118 in. (1.5 - 3.0 mm)

Figure 2. Valve Seat Measurements.

3. Using a micrometer, measure outside diameter of valve stems:
 - a. Intake valve - 0.2126-0.2156 in. (5.40-5.475 mm).
 - b. Exhaust valve - 0.2126-0.2150 in. (5.40-5.460 mm).
 - c. Replace valves if out of limits.
4. Using a micrometer, measure inside diameter of valve guides [0.2165-0.2197 in. (5.50-5.58 mm)]. If out of limits, replace cylinder head.
5. Measure valve sinkage [0.012-0.043 in. (0.3-1.1 mm)] (Figure 3). Replace valves if out of limits.

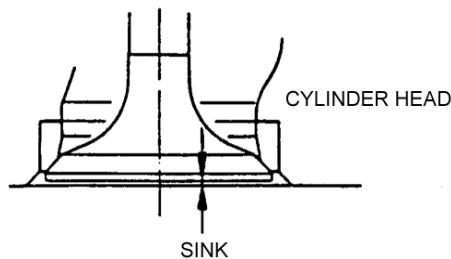

Figure 3. Measuring Valve Sinkage.

6. Measure springs:
 - a. Free length - 1.043-1.102 in. (26.5-28 mm).
 - b. Inclination (distance spring inclines left or right) - 0.030 in. (0.75 mm).
 - c. Spring tension (using a spring tester) - 2.51-3.09 in•lbs (1.14-1.4 kg/mm).

- d. Replace defective springs.

END OF TASK

INSTALLATION

1. Install new intake valve stem seal (Figure 1) in cylinder head.
2. Apply lubricating oil (WP 0162, Table 1, Item 15) to valve stem and insert intake valve into cylinder head.
3. Position washer, spring, and spring seat over valve stem.
4. Using valve spring compressor, compress valve spring and install spring lock.
5. Repeat Steps 1 through 4 to install exhaust valve in cylinder head.
6. Install cylinder head. Refer to WP 0082, Installation.

END OF TASK

ADJUSTMENT

NOTE

Perform valve adjustment when engine is cold.

NOTE

Procedure is the same for intake and exhaust valve.

1. Remove bolts securing valve cover. Then remove valve cover with gasket.
2. Remove cooling fan cover, refer to WP 0065, Removal.
3. Align T mark on flywheel with V notch on cylinder body fin, refer to Figure 4. Ensure both valves are fully closed (both rocker arms have free play).

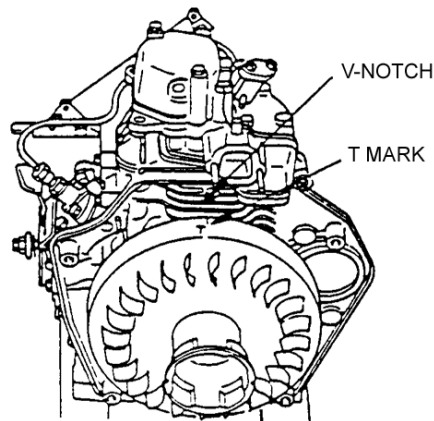

Figure 4. T Position Mark.

4. Loosen nut for adjusting screw and adjust screw until correct clearance [0.006 in. (0.15 mm)] is achieved between rocker arm and valve cap, refer to Figure 5.

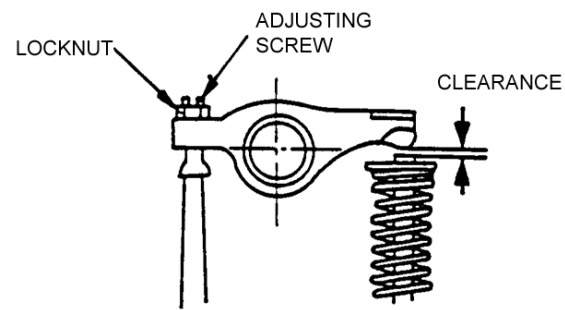

Figure 5. Valve Adjustment.

5. Tighten nut and recheck that clearance is correct.
6. Install gasket and valve cover on cylinder head with bolts.
7. Install cooling fan cover, refer to WP 0065 Installation.

END OF TASK

END OF WORK PACKAGE

FIELD MAINTENANCE**2 kW MEP-501A/531A MILITARY TACTICAL GENERATOR SETS****FUEL INJECTION PUMP: REMOVAL, INSPECTION, INSTALLATION, ADJUSTMENT**

INITIAL SETUP:**Tools and Special Tools**

Tool Kit, General Mechanic's Automotive or Standard Automotive Tool Set (WP 0159, Table 2, Item 6)
Shop Equipment, Automotive Maintenance and Repair, Field Maintenance, Suppl 1 W/O Power (WP 0159, Table 2, Item 4)

Materials/Parts

As required

Equipment Condition

Generator set shut down (WP 0005, Stopping Procedure)
Cable disconnected for NATO Slave Receptacle (WP 0005)

WARNING

The fuels in this generator set are flammable. Do not smoke or use open flames when performing maintenance. Do not service or drain the fuel system while open flames are present. Flames and explosion could result in severe personal injury or death. Use a container or cloth to catch any excess fuel to prevent spilling over engine components. Be sure to properly dispose of diesel fuel and diesel fuel soaked cloths.

REMOVAL**NOTE**

Do not remove fuel injection pump tappet from crankcase.

1. Shut down generator set.
2. Close fuel shutoff valve at fuel filter assembly.
3. Loosen hose clamp and disconnect suction fuel line from fuel injection pump (Figure 1).
4. Disconnect pressure fuel line from fuel injection pump and from fuel injector. Move line aside.
5. Remove nuts and pull fuel injection pump straight out of engine.
6. Remove and retain shim set from engine.

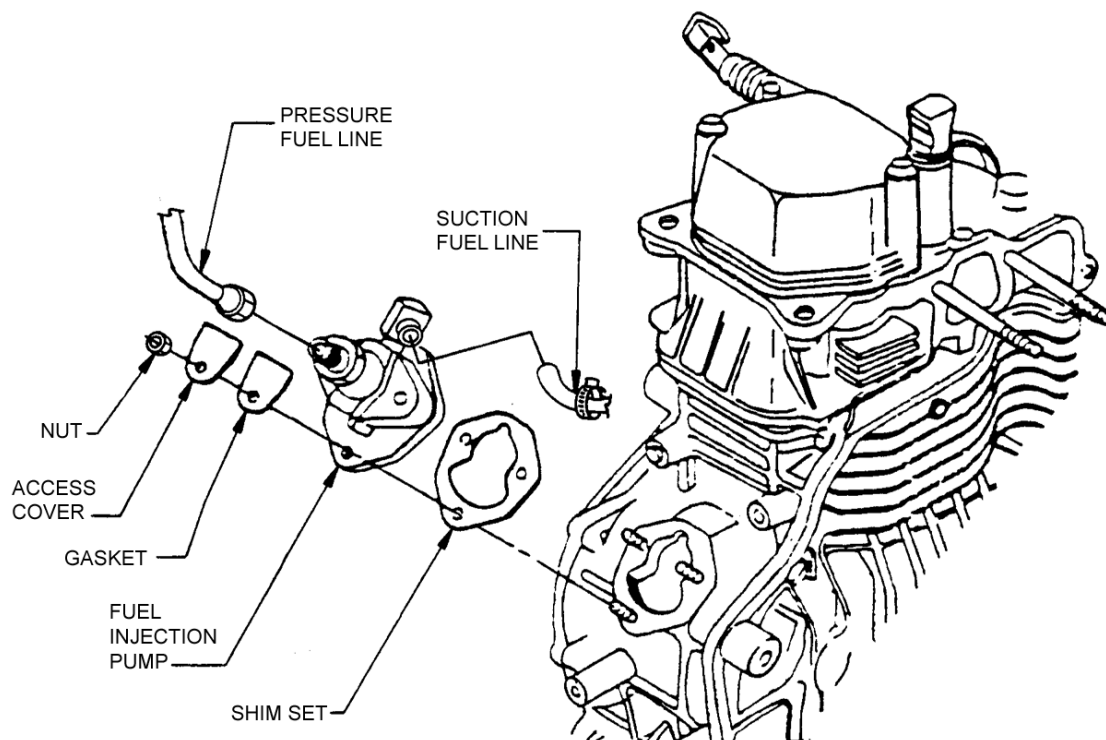

Figure 1. Fuel Injection Pump Removal.

END OF TASK

INSPECTION

1. Inspect fuel injection pump for nicks, cracks, scoring, corrosion, and other damage.
2. Replace pump if damaged.

END OF TASK

INSTALLATION

1. Position shim set (Figure 1) on engine.
2. Move fork of governor lever to center of fuel injection pump port in crankcase by moving RUN lever toward RUN position.
3. Insert fuel injection pump into crankcase port ensuring that lever pointer (Figure 3) enters fork in governor lever.
4. Secure fuel injection pump to engine with top two nuts. Torque nuts to 8 ft•lb (10.8 N•m). Do not install cover and gasket at this time.
5. While watching fuel injection pump lever pointer (Figure 3), move RUN lever back and forth several times ensuring pointer moves in each direction with RUN lever.

CAUTION

Failure to ensure lever pointer is positioned in governor fork could cause engine damage.

6. Install gasket and access cover on fuel injection pump. Torque nut to 8 ft•lb (10.8 N•m).
7. Connect suction fuel line to fuel injection pump and perform adjustment procedures.

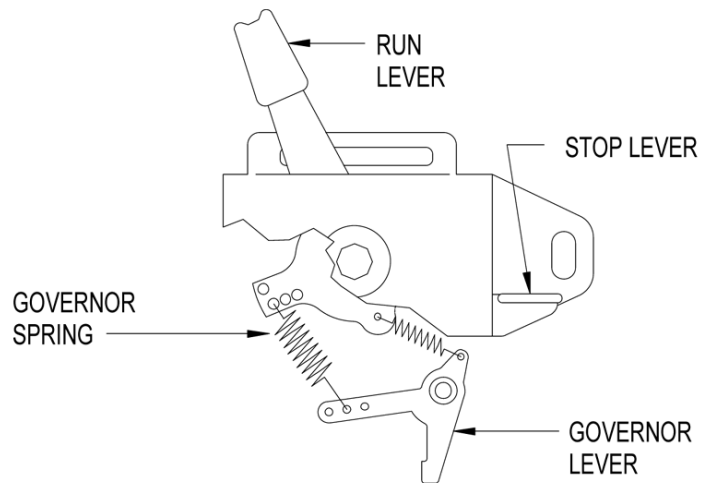

Figure 2. Governor Linkage Setting.

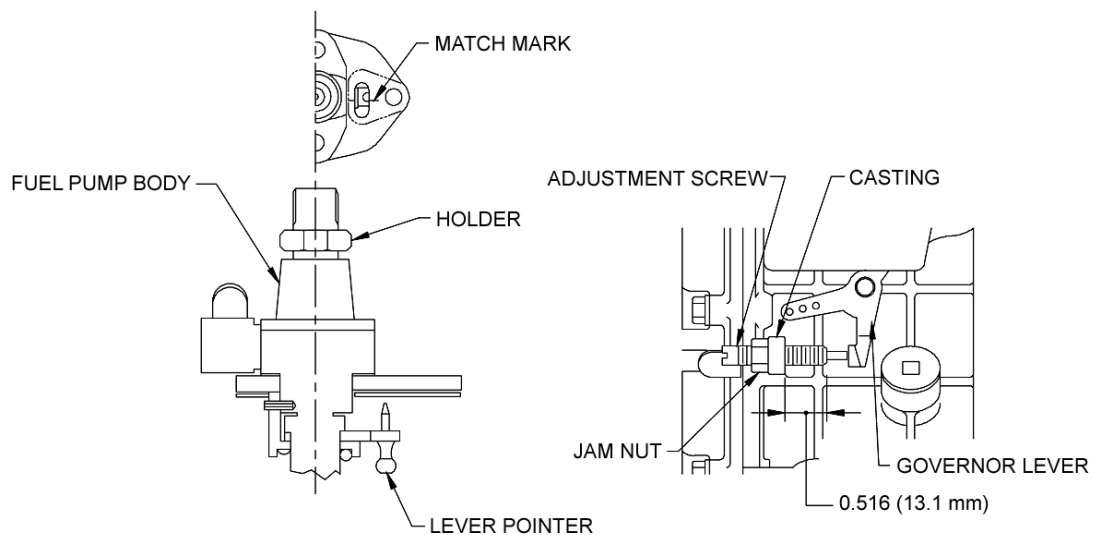

Figure 3. Fuel Injection Limitation Setting.

END OF TASK

ADJUSTMENT

1. Check fuel injection volume limitation setting:
 - a. Ensure that governor linkage and spring position is properly set (Figure 2).
 - b. Measure length of threaded portion of fuel limitation adjustment screw extending forward of adjustment screw casting (Figure 3). Measurement should be 0.516 in. (13.1 mm).

CAUTION

Fuel limitation adjustment screw is factory set and sealed. Any adjustment of screw during warranty period will void warranty.

- c. If necessary, break seal on fuel limitation adjustment screw, loosen jam nut, and adjust screw to achieve measurement stated in Step b.
 - d. Tighten jam nut and install new seal.
2. Check fuel injection timing:

CAUTION

Two sets of timing marks may be stamped on the flywheel. These marks may be on engines with Serial Numbers 39795 and above. The following procedure must be followed: First visually confirm that the flywheel has two distinct sets of marks stamped ninety degrees apart. To do this, locate a set of timing marks at the V notch line on the cylinder body fin (Figure 4). Rotate the flywheel 90 degrees clockwise as viewed from the flywheel side of the engine. Check for a second set of timing marks, if none are found, rotate the flywheel back to the original timing marks. Next, rotate the flywheel counterclockwise 90 degrees, checking for additional timing marks. If no additional marks are found, time the engine in accordance with the procedure below. If two sets of timing marks are found, position the flywheel so that looking from the flywheel side, one set of timing marks at the 12 o' clock position are in line with the V notch line (Figure 4) on the cylinder body fin and the second set of marks are at the 3 o' clock position (90 degrees to the right). When the flywheel is in this position, the correct timing marks are visible at the V notch. Time the engine in accordance with the procedure below.

- a. Remove cooling fan cover, refer to WP 0065, Removal.
- b. Align the T position mark on the flywheel with the V notch on the cylinder body fin (Figure 4).

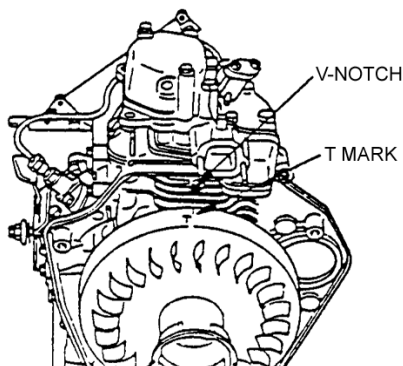

Figure 4. T Position Mark.

- c. If installed, disconnect pressure fuel line from fuel injection pump and fuel injector, and move aside.
- d. Set start lever to RUN.
- e. Turn the flywheel counterclockwise approximately 30°, then turn flywheel clockwise back to T mark, and ensure fuel moves in fuel injection pump. If there is no fuel movement, turn flywheel one full turn clockwise and realign T mark.
- f. Turn flywheel counterclockwise approximately 30° from T, then turn flywheel clockwise until fuel just begins to move in fuel injection pump, record angle before T that fuel begins to move. Each mark on flywheel is equal to 5°.
- g. Repeat Step f three or four times to verify angle. The correct engine timing is 17 +/- 1 BTDC.
- h. Adjust injection timing:
 - (1) Remove fuel injection pump, refer to Removal in this work package.
 - (2) Add shims (Figure 1) if timing angle is more than 17°, or remove shims if timing angle is less than 17°. Each 0.0039 in. (0.1 mm) shim changes timing by 1°.
 - (3) Install fuel injection pump and check timing.

- (4) Repeat procedure until injection timing is correct.
 - i. Reconnect pressure fuel line.
 - j. Reinstall cooling fan cover, refer to WP 0065, Installation.
3. Bleed air from fuel system:
- a. Loosen holder (Figure 3) on fuel injection pump.
 - b. Set start lever to RUN, depress and hold decompression lever down.
 - c. Pull recoil starter rope until fuel flows from under delivery valve holder without air bubbles.
 - d. Torque holder to 22-25 ft•lb (30-34 N•m).

END OF TASK

END OF WORK PACKAGE

FIELD MAINTENANCE**2 kW MEP-501A/531A MILITARY TACTICAL GENERATOR SETS****CRANKCASE COVER: REMOVAL, INSPECTION, INSTALLATION**

INITIAL SETUP:**Tools and Special Tools**

Tool Kit, General Mechanic's Automotive or
Standard Automotive Tool Set
(WP 0159, Table 2, Item 6)

Materials/Parts

As required

Equipment Condition

Generator set shut down (WP 0005, Stopping
Procedure)
Cable disconnected for NATO Slave Receptacle
(WP 0005)

REMOVAL

1. Shut down generator set.
2. Remove diesel engine, refer to WP 0079, Removal.
3. Tag and disconnect electrical lead from low oil pressure switch.
4. Drain diesel engine oil.

CAUTION

Be careful when removing crankcase cover to prevent damage to crankshaft oil seal.

5. Remove capscrews, stiffener bolt, crankcase cover, and gasket from engine.
6. If necessary, remove pins and oil inlet pipe from crankcase cover.
7. If replacing crankcase cover, remove the following:
 - a. Engine oil strainer, refer to WP 0067, Removal.
 - b. Low oil pressure switch, refer to WP 0060, Removal.
 - c. Governor.
 - d. Oil pump, refer to WP 0086, Removal.
 - e. Oil fill cap/dipstick.
 - f. Crankshaft bearing and seal.
 - g. Camshaft bearing.
 - h. Balancer shaft bearing.

END OF TASK**INSPECTION**

1. Inspect crankcase cover for cracks, corrosion, bent pins, damaged oil inlet pipe, and other damage.
2. Inspect for damage to crankshaft oil seal.
3. Replace damaged parts.

INSTALLATION

1. If crankcase cover (Figure 1) was replaced, install the following:

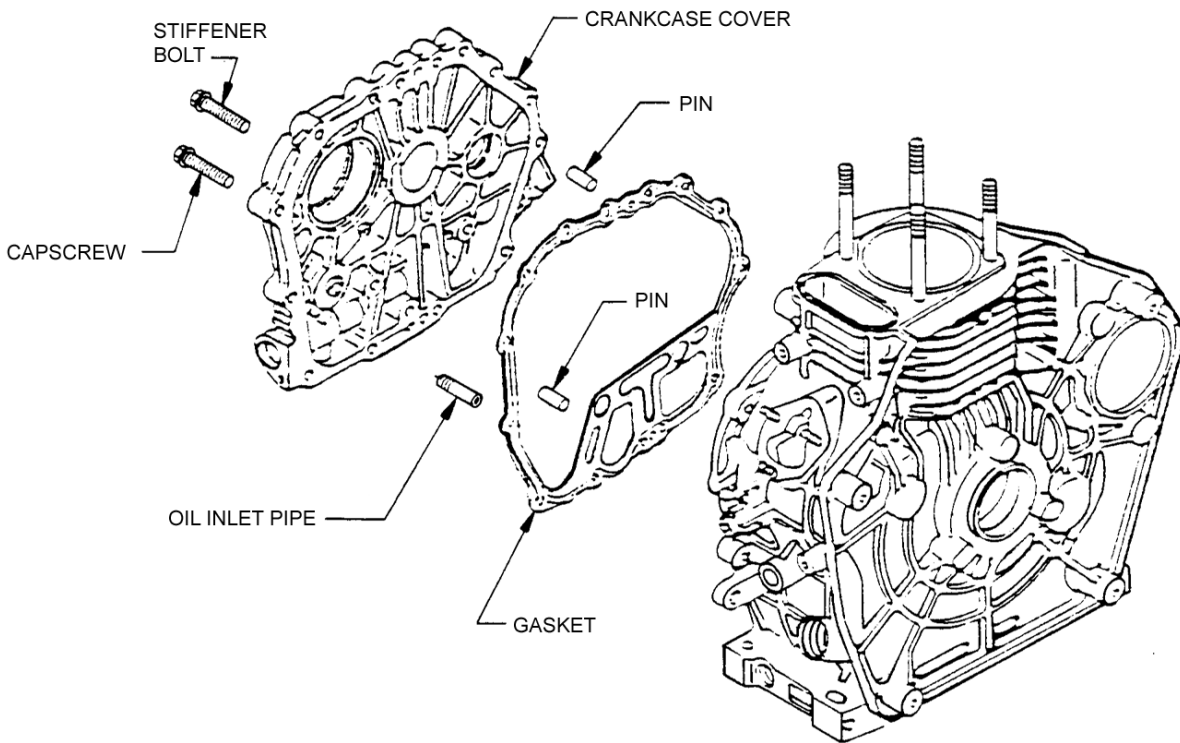
**Crankcase Cover.**

- a. Balancer shaft bearing.
 - b. Camshaft bearing.
 - c. Crankshaft bearing and seal.
 - d. Oil fill cap/dipstick.
 - e. Oil pump, refer to WP 0088, Installation.
 - f. Governor.
 - g. Low oil pressure switch, refer to WP 0060, Installation.
 - h. Engine oil strainer, refer to WP 0067, Installation.
2. If removed, install oil inlet pipe and pins in crankcase cover.
 3. Remove oil pump cover, refer to WP 0086, Removal.

CAUTION

Ensure crankshaft, camshaft, and balancer shaft are aligned with respective bearings and governor gear is aligned with cam shaft gear when positioning crankcase cover on engine. Improper alignment could damage parts. Use care to prevent damage to crankshaft oil seal when installing crankcase cover.

4. Position gasket and crankcase cover on engine while aligning shafts to bearings, governor gear to cam shaft gear by turning oil pump, and pins to holes in cylinder block.
5. Ensure governor gear is aligned with camshaft gear by turning crankshaft and observing that oil pump turns.
6. Install oil pump cover, refer to WP 0086, Installation.

7. Secure crankcase cover with stiffener bolt and capscrews. Torque capscrews to 7-9 ft•lb (10-12 N•m) and stiffener bolt to 15-17 ft•lb (20-23 N•m).
8. Fill diesel engine with fresh engine oil (WP 0162, Table 1, Items 14 and 15), refer to WP 0010, Table 1, Operator Preventive Maintenance Checks and Services for proper oil for operating environment.
9. Connect electrical lead to low oil pressure switch and remove tag.
10. Install diesel engine, refer to WP 0079, Installation.

END OF TASK

END OF WORK PACKAGE

FIELD MAINTENANCE

**2 kW MEP-501A/531A MILITARY TACTICAL GENERATOR SETS
OIL PUMP ASSEMBLY: REMOVAL, INSPECTION, INSTALLATION****INITIAL SETUP:****Tools and Special Tools**

Tool Kit, General Mechanic's Automotive or Standard Automotive Tool Set (WP 0159, Table 2, Item 6)
Shop Equipment, Automotive Maintenance and Repair, Field Maintenance, Suppl 1 W/O Power (WP 0159, Table 2, Item 4)

Materials/Parts

As required

Equipment Condition

Generator set shut down (WP 0005, Stopping Procedure)
Cable disconnected for NATO Slave Receptacle (WP 0005)

REMOVAL

1. Shut down generator set.
2. Remove crankcase cover.
3. Remove governor gear and spindle from oil pump shaft.
4. Remove bolts (Figure 1), cover, and preformed packing from crankcase cover.

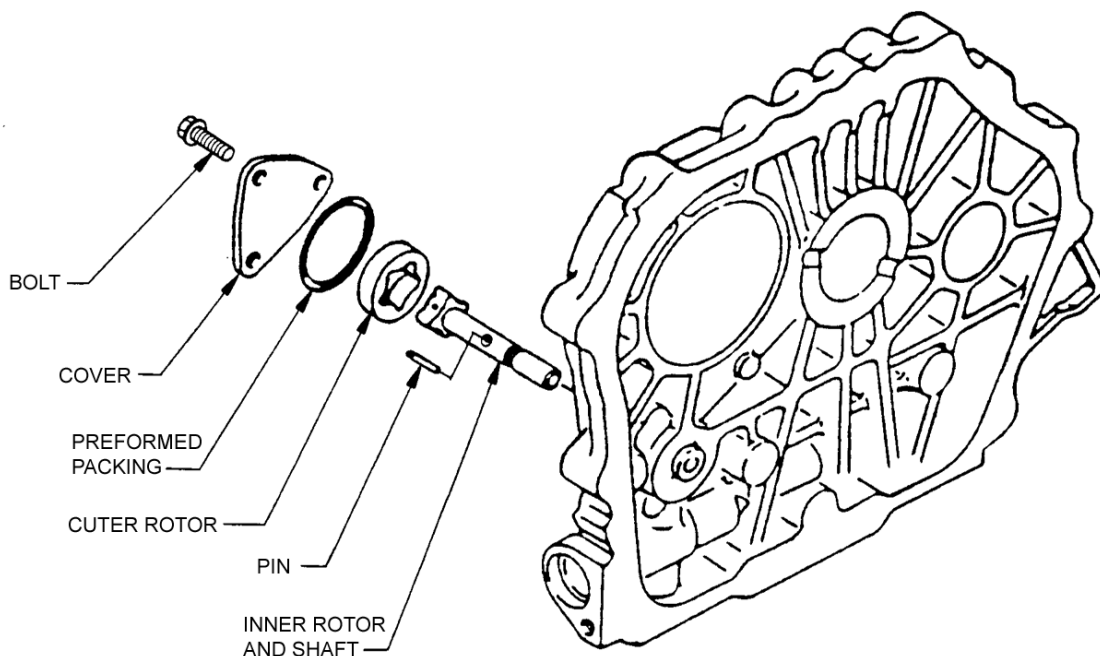

Figure 1. Oil Pump Assembly.

5. Remove pin (from oil pump inner rotor and shaft), outer rotor, and inner rotor and shaft from crankcase cover.

END OF TASK**INSPECTION**

1. Inspect components for cracks, corrosion, signs of overheating, and other damage.
2. Measure outside diameter of outer rotor [1.1378-1.1409 in. (28.90-28.98 mm)].
3. Measure width of inner and outer rotors [0.3110-0.3150 in. (7.90-8.00 mm)].
4. Measure clearance between inner and outer rotors [0.0055-0.0098 in. (0.14-0.25 mm)].
5. Measure oil pump housing in crankcase cover:
 - a. Inside diameter - 1.1457-1.1488 in. (29.100-29.18 mm).
 - b. Depth - 0.3157-0.3189 in. (8.02-8.10 mm).
6. Replace damaged or worn parts.

END OF TASK**INSTALLATION**

1. Insert inner rotor and shaft (Figure 1) through crankcase cover and install pin in shaft so equal amounts protrude on each side.
2. Install outer rotor over inner rotor and new preformed packing in crankcase cover.
3. Install cover loosely with bolts, fill pump cavity with oil, and tighten bolts finger tight and 1/8 turn.
4. Install governor gear and spindle.
5. Install crankcase cover.

END OF TASK**END OF WORK PACKAGE**

FIELD MAINTENANCE**2 kW MEP-501A/531A MILITARY TACTICAL GENERATOR SETS****FLYWHEEL: REMOVAL, INSPECTION, INSTALLATION****INITIAL SETUP:****Tools and Special Tools**

Tool Kit, General Mechanic's Automotive or Standard Automotive Tool Set (WP 0159, Table 2, Item 6)
Shop Equipment, Automotive Maintenance and Repair, Field Maintenance, Suppl 1 W/O Power (WP 0159, Table 2, Item 4)
Flywheel Tightening Handle (WP 0154, Item 1)
Flywheel Extractor (WP 0154, Item 2)

Materials/Parts

Oil, Lubricating (WP 0162, Table 1, Item 14)

Equipment Condition

Generator set shut down (WP 0005, Stopping Procedure)
Cable disconnected for NATO Slave Receptacle (WP 0005)

REMOVAL

1. Shut down generator set.
2. Remove cooling fan cover, refer to WP 0065, Removal.
3. Remove starter pulley from flywheel, refer to WP 0066, Removal.
4. Install flywheel locking handle (Figure 1).

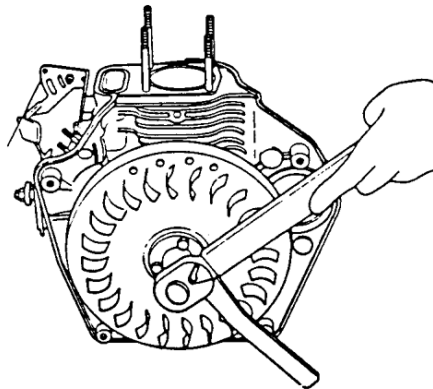

Figure 1. Flywheel Locking Handle.

5. Remove nut (Figure 2) and washer securing flywheel to crankshaft.

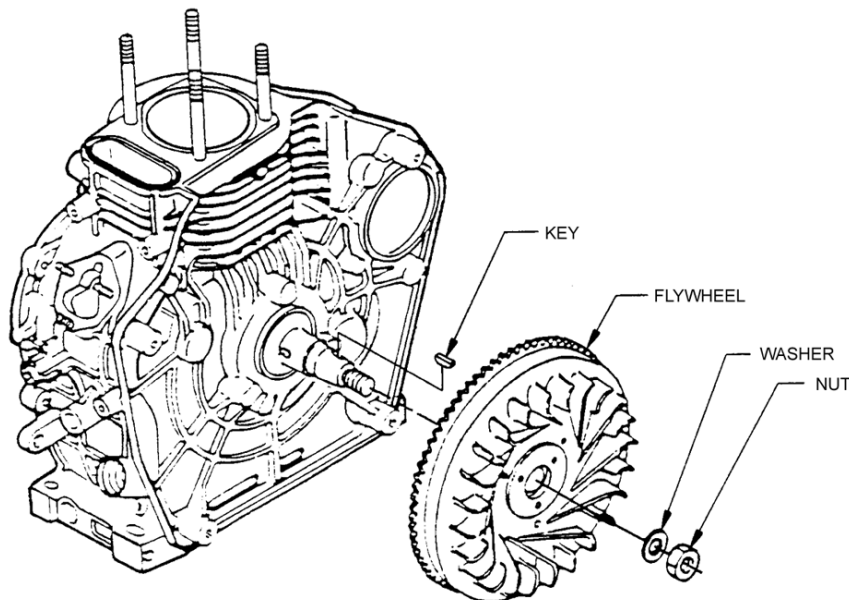

Figure 2. Flywheel.

6. Using flywheel extractor, remove flywheel from crankshaft (Figure 1).
7. Remove key from crankshaft.

END OF TASK

INSPECTION

1. Inspect flywheel for cracks, damaged cooling vanes, worn or broken teeth, and other damage.
2. If replacing damaged flywheel, remove three screws securing rotor wheel to flywheel. Install rotor wheel on replacement flywheel.

END OF TASK

INSTALLATION

1. Position key (Figure 2) in slot on crankshaft.
2. Install flywheel on crankshaft with washer and nut. Apply lubricating oil (WP 0162, Table 1, Item 15) to nut. Using flywheel locking handle to hold flywheel, torque nut to 87-94 ft•lb (118-127 N•m).
3. Install starter pulley on flywheel, refer to WP 0066, Installation.
4. Install cooling fan cover, refer to WP 0065, Installation.

END OF TASK

END OF WORK PACKAGE

FIELD MAINTENANCE**2 kW MEP-501A/531A MILITARY TACTICAL GENERATOR SETS
DYNAMO: TESTING, REMOVAL, INSPECTION, INSTALLATION**

INITIAL SETUP:**Tools and Special Tools**

Tool Kit, General Mechanic's Automotive or Standard Automotive Tool Set (WP 0159, Table 2, Item 6)

Materials/Parts

Grounding Equipment

Personnel Required

91D

References

WP 0004, Description and Use of Operator Controls and Indicators

Equipment Condition

Engine control switch off (WP 0004, Table 1)

TESTING

1. Using multimeter set for volts AC, connect positive lead to TB1-5 and negative lead to TB1-6. (On MEP-501A connect positive lead to TB1-6 and negative lead to TB1-7.)
2. Start generator set and check multimeter indication. Multimeter should indicate 40-50 VAC.
3. If voltage is too low, replace dynamo.
4. If no voltage is indicated, shut down generator and perform the following:
 - a. Tag and disconnect stator wires connected to engine harness at quick disconnects. Then using a multimeter, connect one multimeter lead to either quick disconnect and the other lead to ground. If continuity is indicated, replace dynamo.
 - b. Disconnect engine harness plug (P2) from bottom of control panel assembly.
 - c. Using multimeter, check for continuity between TB1-5 and pin J2-E and between TB1-6 and pin J2-F. (On MEP-501A check for continuity between TB1-6 and pin J2-E and between TB1-7 and pin J2-F.) If continuity is not indicated, repair defective wire.
 - d. Using multimeter, check for continuity between sockets P2-E and P2-F. If continuity is not indicated, tag and disconnect stator wires from engine harness.
 - e. Using multimeter, check engine harness wires P2-E and P2-F for continuity. If continuity is not indicated, repair defective wire.
 - f. Connect engine harness plug (P2), disconnected stator wires, and remove tags.

END OF TASK**REMOVAL**

1. Shut down generator set.
2. Remove cooling fan cover, refer to WP 0065, Removal.
3. Remove flywheel, refer to WP 0087, Flywheel.
4. Tag and disconnect electrical leads for dynamo stator (Figure 1) from engine harness.

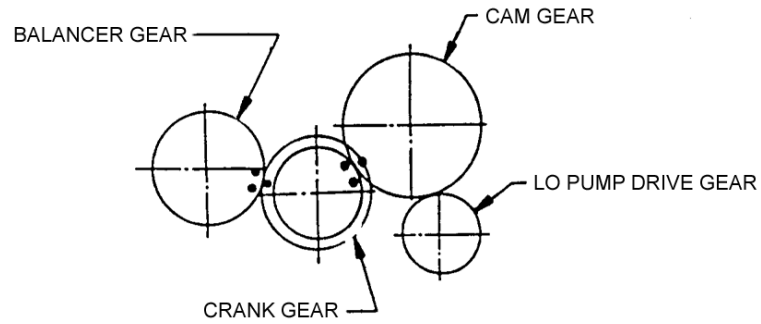

Figure 1. Aligning Timing Marks.

5. Remove bolt and clamp securing wiring to cylinder block.
6. Remove bolts and dynamo stator from cylinder block.
7. If necessary, remove screws and dynamo wheel from flywheel.

END OF TASK

INSPECTION

1. Inspect dynamo components for cracks, damaged insulation, and other damage.
2. Replace damaged parts.

END OF TASK

INSTALLATION

1. If removed, install dynamo wheel (Figure 2) on flywheel with screws.

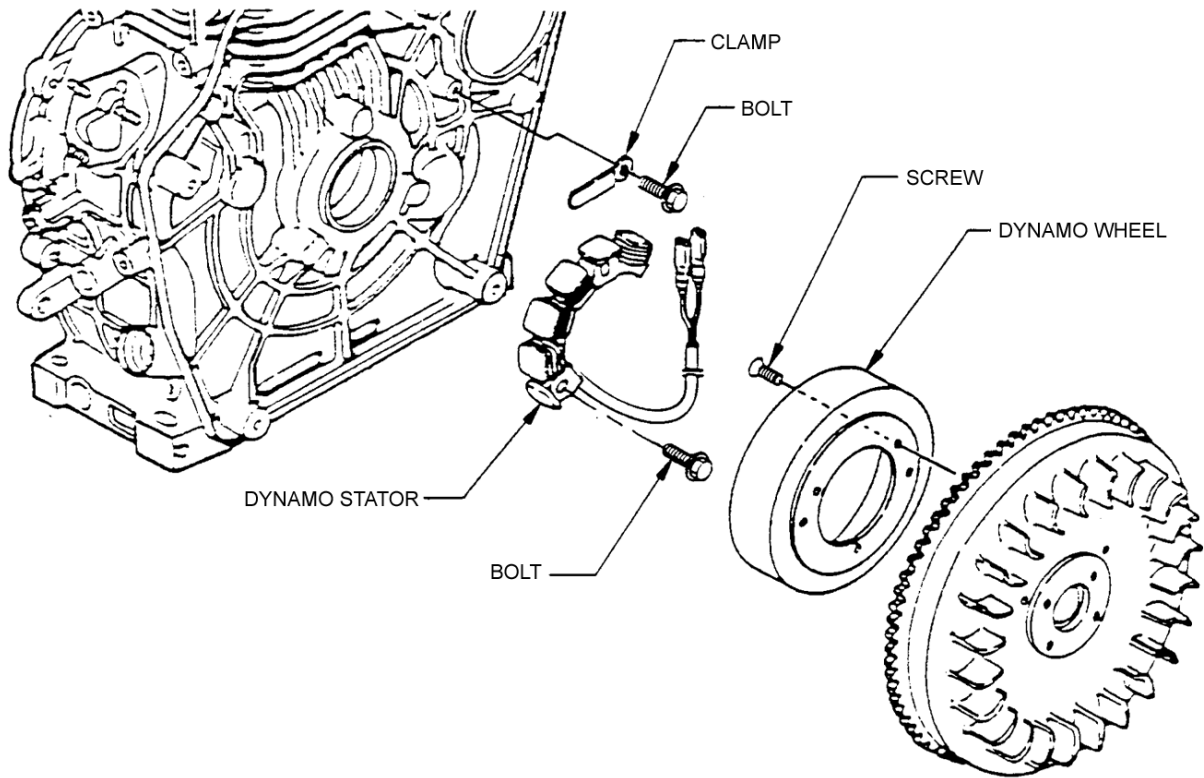

Figure 2. Dynamo.

2. Install dynamo stator on cylinder block with bolts.
3. Route electrical leads through cylinder block, pull out excess wiring, and secure to cylinder block with clamp and bolt.
4. Install flywheel, refer to WP 0087, Installation.
5. Install cooling fan cover, refer to WP 0065, Installation.
6. Perform performance test, refer to the Testing section of this work package.

END OF TASK

END OF WORK PACKAGE

FIELD MAINTENANCE**2 kW MEP-501A/531A MILITARY TACTICAL GENERATOR SETS****AC ALTERNATOR ASSEMBLY (MEP-531A): REMOVAL, DISASSEMBLY, ASSEMBLY, INSPECTION,
TESTING, INSTALLATION**

INITIAL SETUP:**Tools and Special Tools**

Tool Kit, General Mechanic's Automotive or
Standard Automotive Tool Set
(WP 0159, Table 2, Item 6)
Shop Equipment, Automotive Maintenance and
Repair, Field Maintenance, Suppl 1 W/O Power
(WP 0159, Table 2, Item 4)
Multimeter (WP 0159, Table 2, Item 3)

Materials/Parts

Compound, Locking (WP 0162, Table 1, Item 7)

Equipment Condition

Generator set shut down (WP 0005, Stopping
Procedure)
Cable disconnected for NATO Slave Receptacle
(WP 0005)

REMOVAL

1. Remove engine/alternator assembly. Refer to WP 0078, Removal.
2. Remove capscrews (Figure 1, Item 1), lockwashers (2), washers (3), and alternator guard (4) from alternator.
3. Tag stator wires and brush wires (6) connected by screws (5).
4. Remove screws (5), brush wires (6), and stator wires from bearing bracket (16).
5. Remove brush caps (7) and brushes (8) from bearing bracket (16).
6. Remove nuts (9 and 10), lockwashers (11), washers (12), bolts (13), washers (14), ground strap (15), and bearing bracket (16) from stator assembly (18) and support bracket (17). Remove tie wraps as required.

CAUTION

Do not contact stator windings with rotor when removing stator assembly. Damage to stator and rotor may result. Also use care to avoid damage to LOP switch.

7. Carefully remove stator assembly (18) and support bracket (17).
8. Loosen capscrew (19) and remove C-washer (20) from capscrew.

CAUTION

Do not tap on rotor windings or allow rotor to fall when removing rotor from engine shaft. Damage to windings may result.

9. While supporting rotor (21), tap on rotor yoke casting using a brass drift and hammer. Tap with yoke parallel to work surface until rotor (21), with fan (23) attached, separates from engine shaft.
10. Remove capscrew (19) from engine shaft.
11. Remove bolts (24), lockwashers (25), washers (26), and adapter plate (27) from engine.

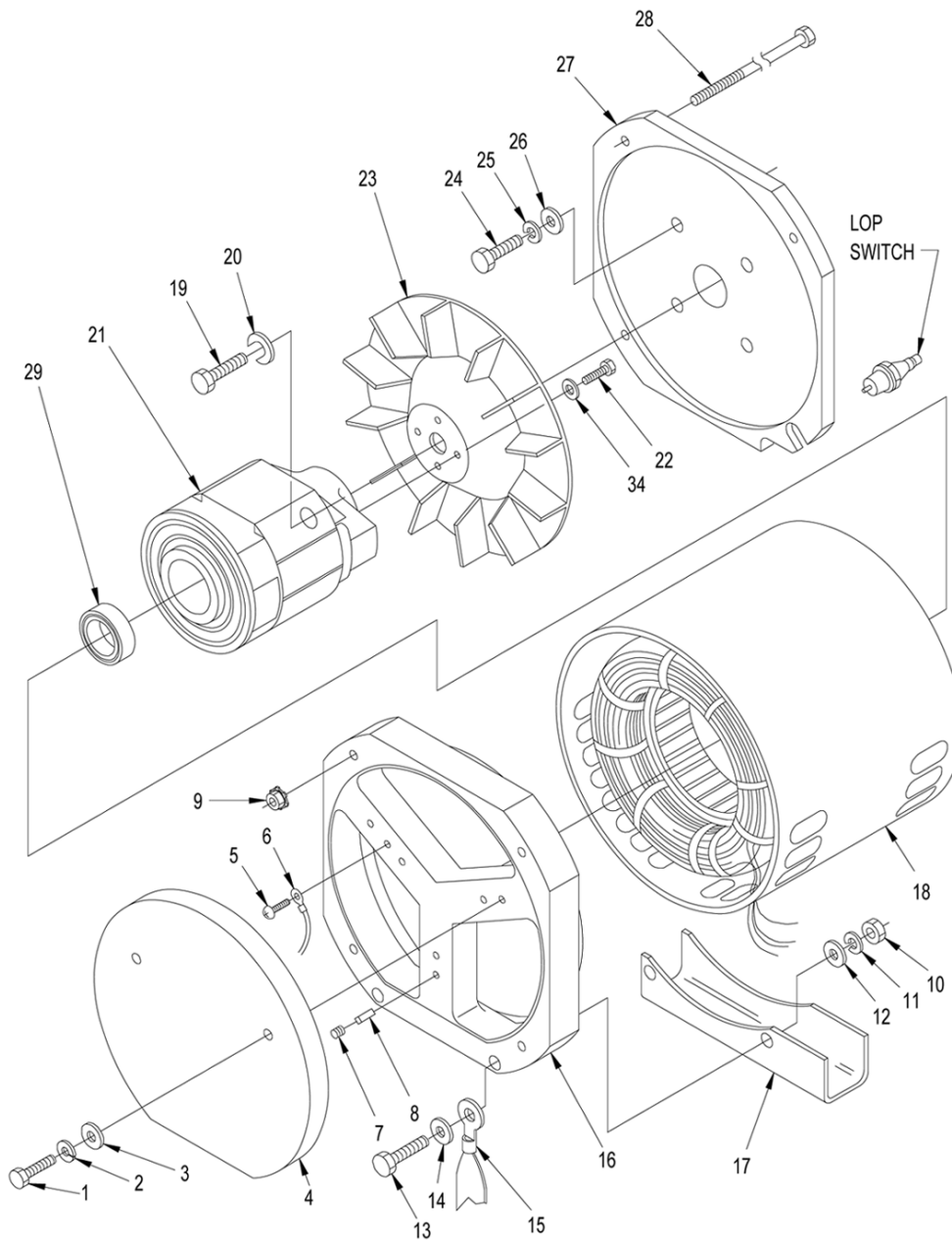

LEGEND

- | | | | |
|----|------------------|----|-----------------|
| 1 | Capscrew | 16 | Bearing Bracket |
| 2 | Lockwasher | 17 | Support Bracket |
| 3 | Washer | 18 | Stator Assembly |
| 4 | Alternator Guard | 19 | Capscrew |
| 5 | Screw | 20 | C-washer |
| 6 | Wires | 21 | Rotor |
| 7 | Brush Cap | 22 | Bolt |
| 8 | Brush Cap | 23 | Fan |
| 9 | Nut | 24 | Bolt |
| 10 | Nut | 25 | Lockwasher |
| 11 | Lockwasher | 26 | Washer |
| 12 | Washer | 27 | Adapter Plate |
| 13 | Bolt | 28 | Thru Bolt |
| 14 | Washer | 29 | Bearing |
| 15 | Ground Strap | | |

Figure 1. AC Alternator Assembly (MEP-531A) (Sheet 1 of 2).

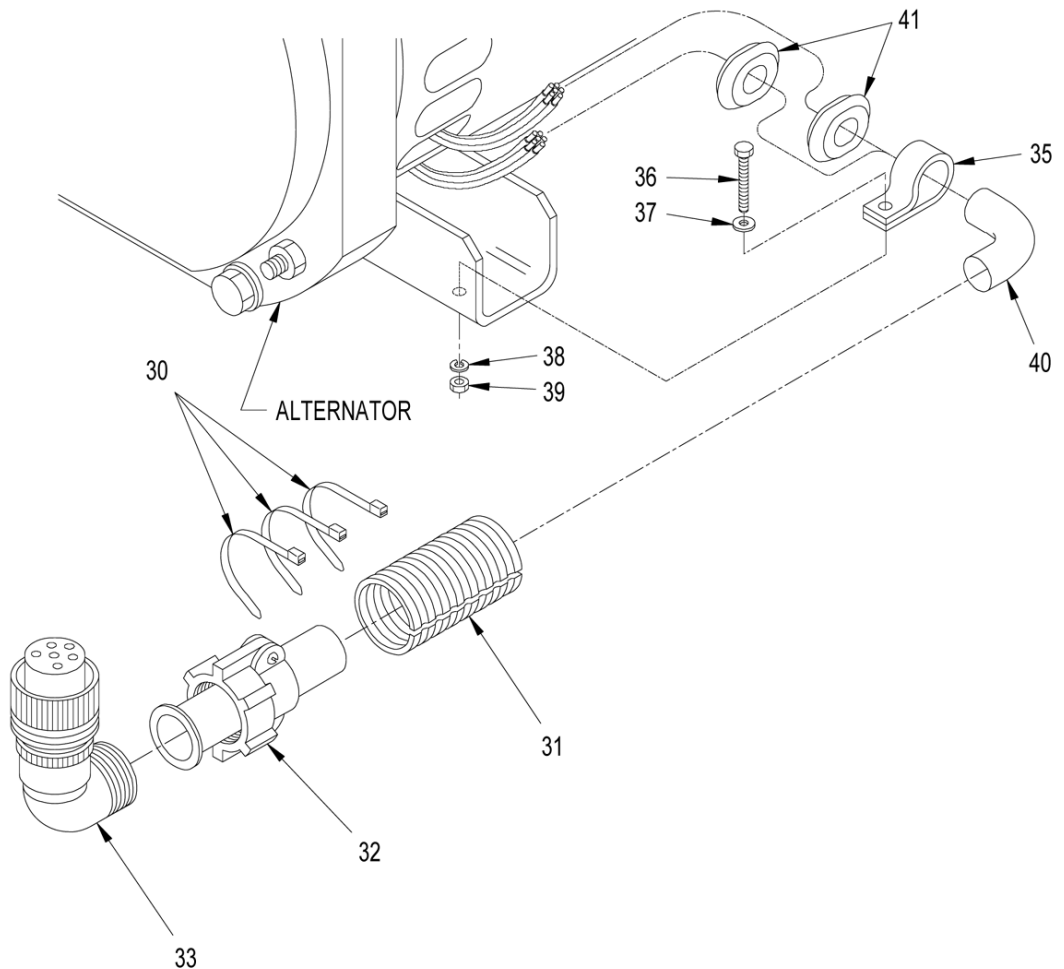

LEGEND

- 30 Tie down Strap
- 31 Tubing
- 32 Clamp
- 33 Connector Plug
- 34 Washer
- 35 Clamp, Cable

- 36 Screw
- 37 Washer
- 38 Lockwasher
- 39 Nut
- 40 Insulation Sleeving
- 41 Grommet

Figure 1. AC Alternator Assembly (MEP-531A) (Sheet 2 of 2).

END OF TASK

DISASSEMBLY

1. Inspect alternator brushes. Refer to WP 0020, Inspection.
2. Remove bolts (Figure 1, Item 22), washers (34), and fan (23) from rotor (21).
3. Remove thru bolts (28) from adapter plate (27).
4. If necessary, using suitable puller, remove bearing (29) from rotor (21).

CAUTION

DO NOT REMOVE power harness components unless testing results in a need to replace stator assembly. Unnecessary removal and installation of components is time consuming and damage may occur.

5. If necessary to replace stator assembly (18), remove power harness components as follows:
 - a. Remove nut (39), lockwasher (38), washer (37), and screw (36) securing clamp (35) to bracket (17).
 - b. Cut tie down straps (30) and remove convoluted tubing (31) and insulation sleeving (40) from cable.
 - c. Cut cable wires four inches down from clamp (32).
 - d. Remove grommets (41) from stator assembly (18) and slide off cable wires.

END OF TASK

ASSEMBLY

NOTE

If replacing rotor (Figure 1, Item 21), also replace bearing bracket (16) and bearing (29).

1. If stator assembly (Figure 1, Item 18) was replaced, install power cable components as follows:
 - a. Slide grommets (41) over cable wires and install in vent holes where cable wires exit stator.
 - b. Position insulation sleeving (40) on cable wiring. Then push wiring through clamp (32).
 - c. Match cable wire numbers to corresponding plug wires and splice together. Refer to Table 1 for connection positions. Tighten clamp (32).
 - d. Position convoluted tubing (31) on cable wires and secure with tie down straps (30).
 - e. Secure harness to support bracket (17) with clamp (35), screw (36), washer (37), lockwasher (38), and nut (39).
2. If removed, install bearing (29) in rotor (21).
3. Insert thru bolts (28) in adapter plate (27).
4. Install fan (23) on rotor (21) with washers (34) and bolts (22).

Table 1. Power Harness Connector Plug Connections.

WIRE NUMBER	TERMINATION	
	FROM	TO
S-1	G2-1	P1-A
S-2	G2-2	P1-B
S-3	G2-3	P1-C
S-4	G2-4	P1-D
S-5	G2(+)	P1-E
S-6	G2(-)	P1-F

END OF TASK

INSPECTION

1. Inspect all components for cracks, corrosion, stripped threads, and other damage.
2. Inspect fan for damaged vanes.
3. Inspect bearing bracket O-ring. If O-ring is damaged or missing, replace bearing bracket.

CAUTION

If there is any unusual wear to bearing (Figure 1, Item 29), or if bearing bracket (16) does not meet minimum dimension stated in Step 4, the bearing bracket must be replaced.

4. Measure diameter of shaft on bearing bracket [minimum of 0.7868 in. (20.2 mm)].
5. Inspect rotor windings for damage and slip rings for grooves and pitting.
6. Inspect stator windings for damage and signs of overheating (discolored or burned windings).
7. Replace damaged or worn parts.

END OF TASK

TESTING (ALTERNATOR INSTALLED)

1. Rotor:
 - a. Using multimeter, measure resistance across the windings at P1-E and P1-F. Resistance should be 13-18 ohms. If readings are not as stated, disassemble alternator and perform rotor testing. Continue to Step b.
 - b. Using a multimeter, measure resistance across the windings. Resistance should be 13-14 ohms. Replace rotor if resistance is not as stated.
 - c. Using a multimeter, check for continuity from each slip ring to ground. If continuity is indicated, rotor is defective and must be replaced.
2. Stator:
 - a. Using a multimeter, measure resistance between P1 sockets P1-A and P1-B. Resistance should be 0.7-1.0 ohm. Replace stator if resistance is not as stated.
 - b. Using a multimeter, measure resistance between P1 sockets P1-C and P1-D. Resistance should be 0.7-1.0 ohm. Replace stator if resistance is not as stated.
 - c. Using a multimeter, check for open circuit between P1 sockets P1-A and P1-C, P1-A and P1-D, P1-B and P1-C, and P1-B and P1-D. Replace stator if resistance is found.

INSTALLATION

1. Position adapter plate (Figure 1, Item 27) with notch on LOP switch side. Then apply locking compound (WP 0162, Table 1, Item 7) to threads of bolts (24) and install adapter plate (27) on engine with washers (26), lockwashers (25), and bolts (24).
2. Install rotor (21) as follows:

CAUTION

Ensure inner taper of rotor and outer taper of engine shaft are clean of rust and oil.

- a. Apply locking compound (WP 0162, Table 1, Item 7) to threads of capscrew (19) and screw capscrew (19) into end of engine shaft until there is approximately 3/8 in. (9.5 mm) between head of bolt and engine shaft.

CAUTION

Do not allow capscrew (19) to contact rotor windings. If necessary, screw the capscrew further into engine shaft.

- b. Carefully align rotor (21) and engine shaft and push rotor toward engine until shaft taper seats inside rotor yoke casting.

CAUTION

Do not allow C-washer (20) to shift while tightening capscrew (19). This could adversely affect the integrity of the attachment joint.

- c. Place a new C-washer (20) between the rotor yoke casting and head of capscrew (19). Tighten capscrew (19) until C-washer (20) starts to deform (properly deformed when .020 in. (0.51 mm) feeler gauge will slip between C-washer and yoke of rotor).

CAUTION

Do not tap on stator assembly windings when seating stator on adapter plate.

3. With stator assembly (18) shell seam down, position stator assembly over rotor and onto adapter plate (27). Using a soft faced mallet, tap on end of stator assembly shell to seat on adapter plate.
4. With the vertical portion of the "Y" positioned at the bottom, align bearing bracket (16) to the stator assembly lip and the stub shaft with inner race of bearing (29).

CAUTION

Do not attempt to seat bearing bracket to stator assembly by tightening thru bolts (28). Seat bearing bracket by tapping in the center of the bracket. Tightening the thru bolts or tapping in other than the center of the bracket could cock the bearing or fracture the molded bearing support and slip ring of the rotor.

5. Using a soft faced mallet, carefully tap on center of bearing bracket (16) until bracket is fully seated on shell of stator assembly (18) and stub shaft is seated in bearing (29).

CAUTION

The top surfaces of bearing bracket (16) and adapter plate (27) must be parallel to prevent twisting. If bracket and plate are not parallel, alternator can be severely damaged.

6. Insert thru bolts (28) through bearing bracket (16), install keps nuts (9), and tighten nuts diagonally to 75 in•lb. (8.5 N•m) making sure bottom of bracket remains perfectly straight.
7. Secure support bracket (17) and ground strap (15) to bearing bracket (16) with washers (14), bolts (13), washers (12), lockwashers (11), and nuts (10).
8. Ensure a clearance of .006 in. (.15 mm) exists between stator and rotor windings, and rotor turns freely with no interference.
9. Install brushes (8) in bearing bracket with brush caps (7).
10. Connect stator wires and brush wires (6) with screws (5) and remove tags.
11. Install alternator guard (4) on alternator with washers (3), lockwashers (2), and screws (1). Cross tighten screws to 6 ft•lb (8.2 N•m).
12. Install engine/alternator assembly. Refer to WP 0078, Installation.

END OF TASK

END OF WORK PACKAGE

FIELD MAINTENANCE

**2 kW MEP-501A/531A MILITARY TACTICAL GENERATOR SETS
AC ALTERNATOR BEARING (MEP-531A): REMOVAL, INSTALLATION**

INITIAL SETUP:**Tools and Special Tools**

Tool Kit, General Mechanic's Automotive or Standard Automotive Tool Set (WP 0159, Table 2, Item 6)
Shop Equipment, Automotive Maintenance and Repair, Field Maintenance, Suppl 1 W/O Power (WP 0159, Table 2, Item 4)

Materials/Parts

As required

Equipment Condition

Generator set shut down (WP 0005, Stopping Procedure)
Cable disconnected for NATO Slave Receptacle (WP 0005)

REMOVAL

1. Remove control panel assembly. Refer to WP 0032, Removal.
2. Remove bolts (Figure 1), lockwashers, washers and alternator guard from alternator.

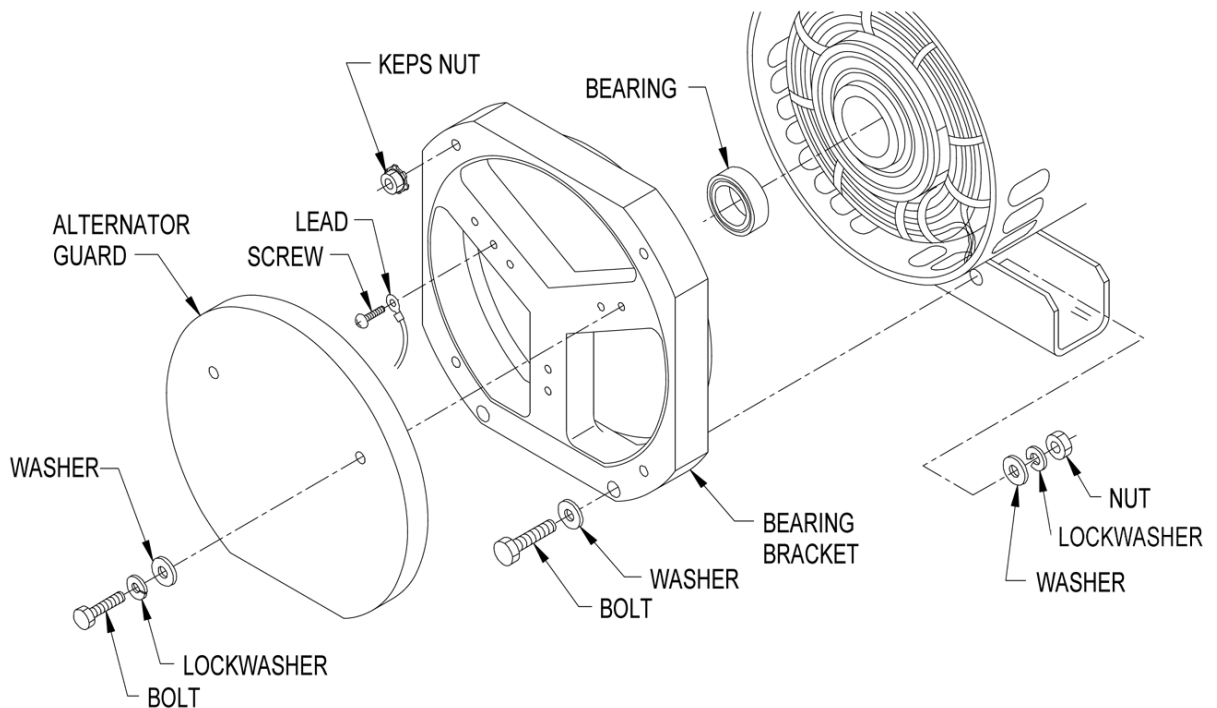

Figure 1. AC Alternator Bearing.

3. Tag and disconnect electrical leads secured by screws.
4. Remove nuts, lockwashers, washers, bolts, and bearing bracket from alternator.

5. Using suitable puller, pull bearing from alternator rotor.

END OF TASK

INSTALLATION

1. Press bearing (Figure 1) into alternator rotor.
2. With the vertical portion of the "Y" positioned at the bottom, align bearing bracket (WP 0089, Figure 1, Item 16) to the stator assembly lip and the stub shaft with inner race of bearing (29).

CAUTION

Do not attempt to seat bearing bracket to stator assembly by tightening thru bolts (28). Seat bearing bracket by tapping in the center of the bracket. Tightening the thru bolts or tapping in other than the center of the bracket could cock the bearing or fracture the molded bearing support and slip ring of the rotor.

3. Using a soft faced mallet, carefully tap on center of bearing bracket (16) until bracket is fully seated on shell of stator assembly (18) and stub shaft is seated in bearing (29).

CAUTION

The top surfaces of bearing bracket (16) and adapter plate (27) must be parallel to prevent twisting. If bracket and plate are not parallel, alternator can be severely damaged.

4. Insert thru bolts (28) through bearing bracket (16), install keps nuts (9), and tighten nuts diagonally to 75 in•lb. (8.5 N•m) making sure bottom of bracket remains perfectly straight.
5. Secure support bracket (17) and ground strap (15) to bearing bracket (16) with washers (14), bolts (13), washers (12), lockwashers (11), and nuts (10).
6. Ensure a clearance of 0.006 in. (0.15 mm) exists between stator and rotor windings, and rotor turns freely with no interference.
7. Install brushes (8) in bearing bracket with brush caps (7).
8. Connect stator wires and brush wires (6) with screws (5) and remove tags.
9. Install alternator guard (4) on alternator with washers (3), lockwashers (2), and screws (1). Cross tighten screws to 6 ft•lb (8.2 N•m).
10. Install control panel assembly. Refer to WP 0032, Installation.

END OF TASK

END OF WORK PACKAGE

FIELD MAINTENANCE**2 kW MEP-501A/531A MILITARY TACTICAL GENERATOR SETS****DC ALTERNATOR ASSEMBLY (MEP-501A): REMOVAL, DISASSEMBLY, INSPECTION, TESTING,
ASSEMBLY, INSTALLATION**

INITIAL SETUP:**Tools and Special Tools**

Tool Kit, General Mechanic's Automotive or
Standard Automotive Tool Set
(WP 0159, Table 2, Item 6)
Shop Equipment, Automotive Maintenance and
Repair, Field Maintenance, Suppl 1 W/O Power
(WP 0159, Table 2, Item 4)
Multimeter (WP 0159, Table 2, Item 3)

Materials/Parts

Isopropyl Alcohol (WP 0162, Table 1, Item 13)
Compound, Locking (WP 0162, Table 1, Item 7)
Compound, Retaining (WP 0162, Table 1, Item 8)

Equipment Condition

Generator set shut down (WP 0005, Stopping
Procedure)
Cable disconnected for NATO Slave Receptacle
(WP 0005)

REMOVAL

1. Shut down generator set.
2. Remove control panel assembly. Refer to WP 0032, Removal.
3. Remove capscrews, lockwashers, washers, and guard from engine adapter (Figure 1).
4. Tag and disconnect electrical leads from alternator, support rear of alternator, then remove self locking nuts with washers and capscrews with washers and ground strap securing alternator to engine adapter. Carefully remove alternator and flexible sleeve coupling.
5. Remove bolts, lockwashers, washers, and engine adapter from engine.
6. Loosen setscrews and remove flexible flange coupling from crankshaft adapter using standard gear puller.
7. If crankshaft adapter is damaged, apply heat to screw and remove screw and countersunk washer securing crankshaft adapter. Then apply heat to crankshaft adapter and using a suitable gear puller, remove crankshaft adapter from crankshaft. Discard screw, machine key, and adapter.

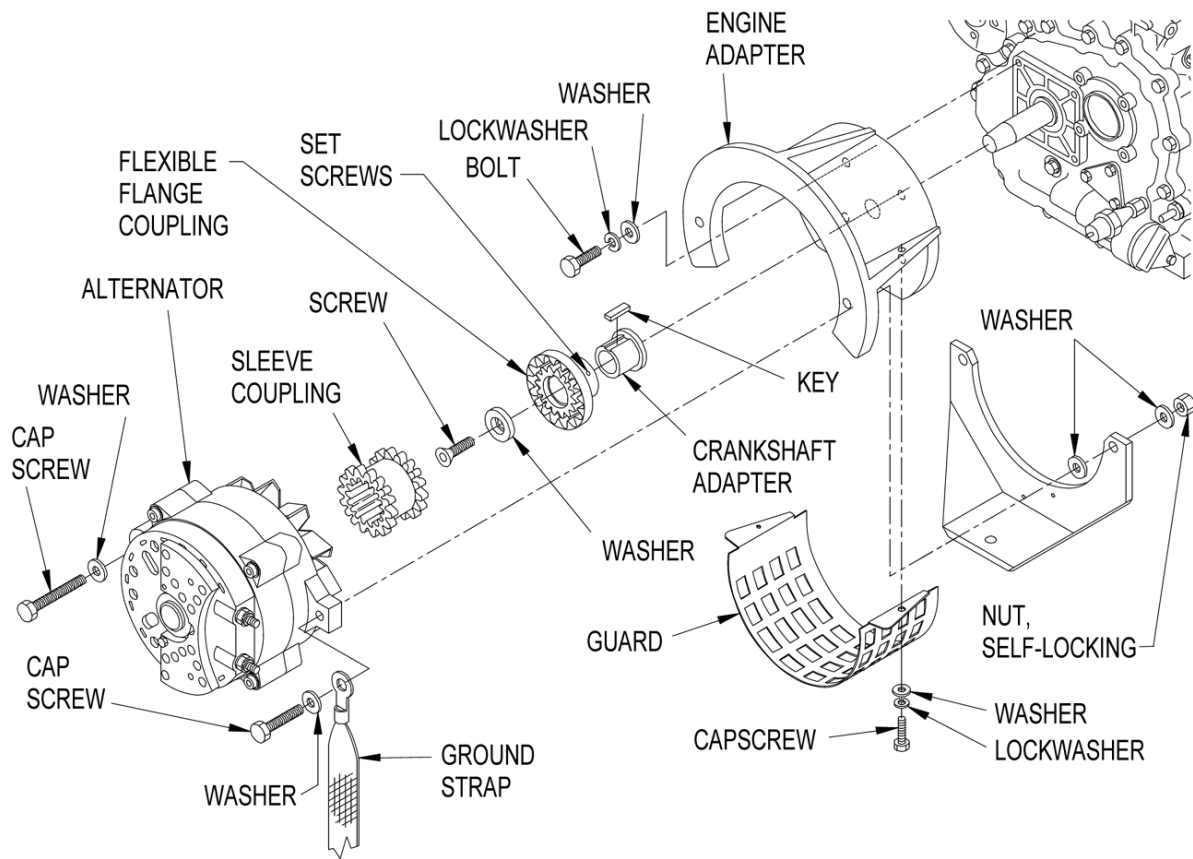

Figure 1. DC Alternator Installation (MEP-501A).

END OF TASK

DISASSEMBLY

1. Hold rotor shaft from turning using an Allen wrench inserted in end of shaft, and remove nut and lockwasher from rotor shaft (Figure 2).
2. Loosen setscrews securing drive pulley to rotor shaft. Then using suitable puller, remove drive pulley. It may be necessary to gently tap the outside diameter of the pulley with a plastic mallet.
3. Remove key, fan, and bushing.
4. Match mark housings, remove four socket head screws, and carefully separate rear housing with stator from rotor and front housing.

NOTE

When separating the rear housing from the rotor, the brushes and springs will pop out. The brushes can be reinserted and retained by a pin (straightened paper clip, etc.) through the access hole in the back of the alternator housing. The pin will aid during alternator assembly.

5. Tag stator leads. Then remove nuts from heat sink tie points (6 places) and carefully separate stator from rear housing. Reinstall nuts on tie points to retain diode leads (Figure 3).
6. If necessary, remove nuts and washers securing brush holder. Remove brush holder.
7. If necessary, separate rotor and front housing.
8. If necessary, remove nuts, tie bar, washers, and insulators from positive terminals.
9. If necessary, replace bearings. Refer to WP 0092, Removal.

10. If necessary, replace diodes and capacitors. Refer to WP 0093, Removal.

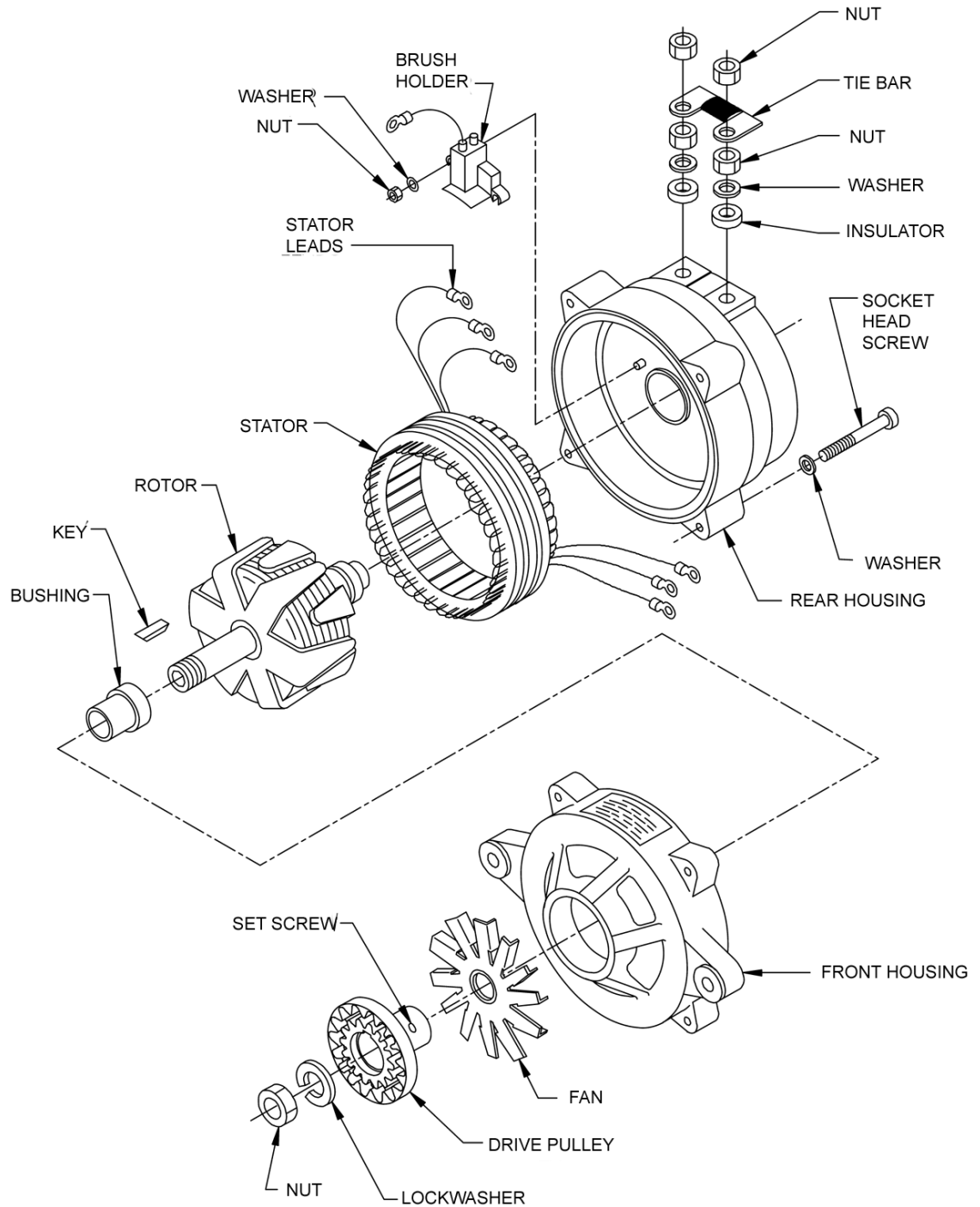

Figure 2. DC Alternator Assembly.

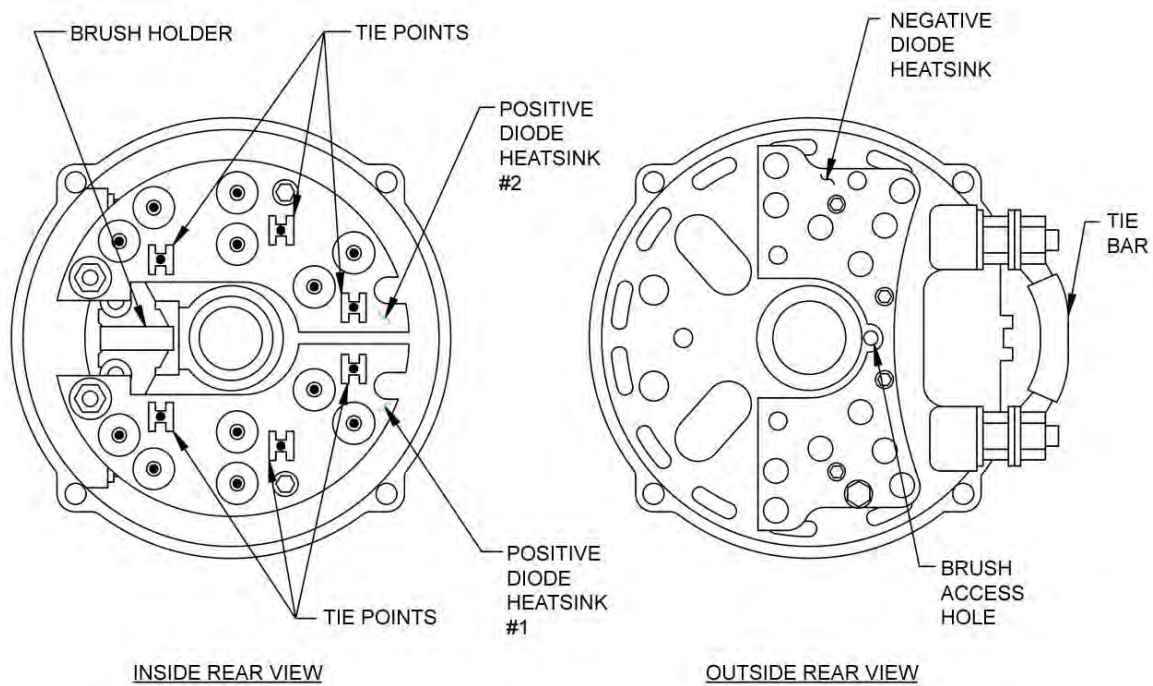

Figure 3. Heatsink Tie Point Locations.

END OF TASK

INSPECTION

1. Inspect all components for damage and wear.
2. Inspect alternator drive coupling (part of alternator) for damage and wear.
3. Inspect brushes in brush holder for discoloration and wear.
4. Inspect stator and rotor for discoloration and damage.
5. Inspect bearings for wear.

END OF TASK

TESTING

1. Test diodes as follows:
 - a. Disconnect diode assembly leads, then using multimeter set for ohms, connect one lead to disconnected diode leads and other lead to heat sink. Note ohms indication on multimeter.

NOTE

Ensure test point on external (negative) heat sink is bare metal.

- b. Reverse multimeter leads and note ohms indication on multimeter.
- c. Resistance (ohms) readings should be high in one direction and low in the other. If readings are high or low in both directions, diodes are defective and must be replaced.
- d. Repeat Steps a, b, and c for each set of diodes.

2. Using multimeter set for ohms, check for continuity between point A and brush B, between terminal C and brush spring D, and between terminal E and connector F (Figure 4). Replace brush or brush assembly as necessary if indications are other than stated.
3. Using multimeter set for ohms, check stator for open circuits between point G (laminations) and each stator terminal (Figure 5). If continuity is noted between laminations and any terminal, stator is defective and must be replaced.
4. Using multimeter set for ohms, check for continuity between all combinations of terminals A, B, and C. Check for continuity between all combinations of terminals D, E, and F. Check for open circuits between all combinations of terminals A, B, and C to terminals D, E, and F. Replace stator if indications are other than stated.

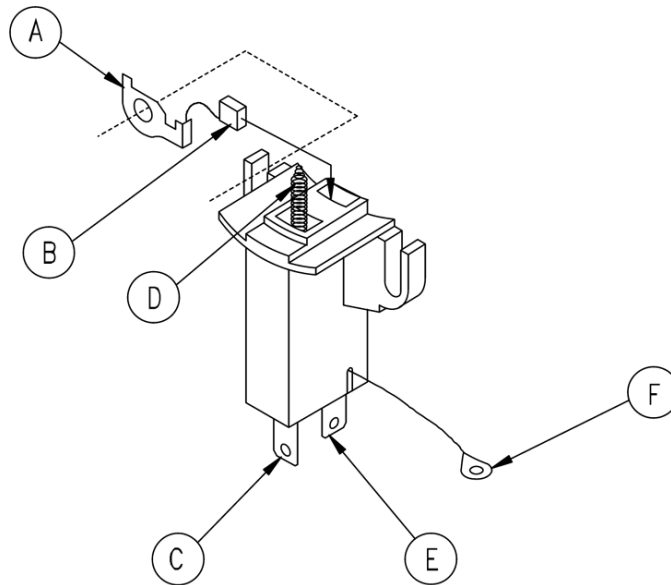

Figure 4. Brush Assembly Test.

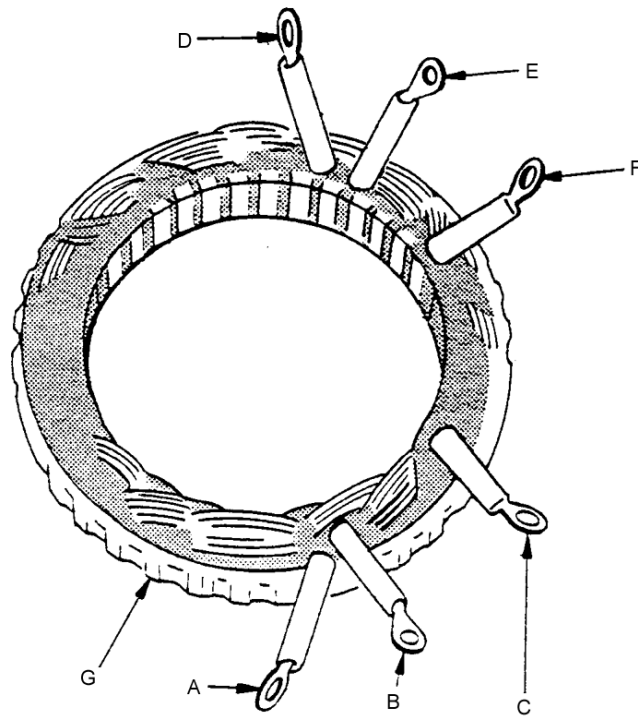

Figure 5. Stator Test.

NOTE

Place multimeter test leads on edges of slip rings to avoid creating arcs on brush contact surfaces.

- Using multimeter set for ohms, check rotor for between 3 and 3.5 ohms between slip rings (Figure 6). Also check for open circuits between rotor body and each slip ring. Replace entire rotor assembly if indications are other than stated.

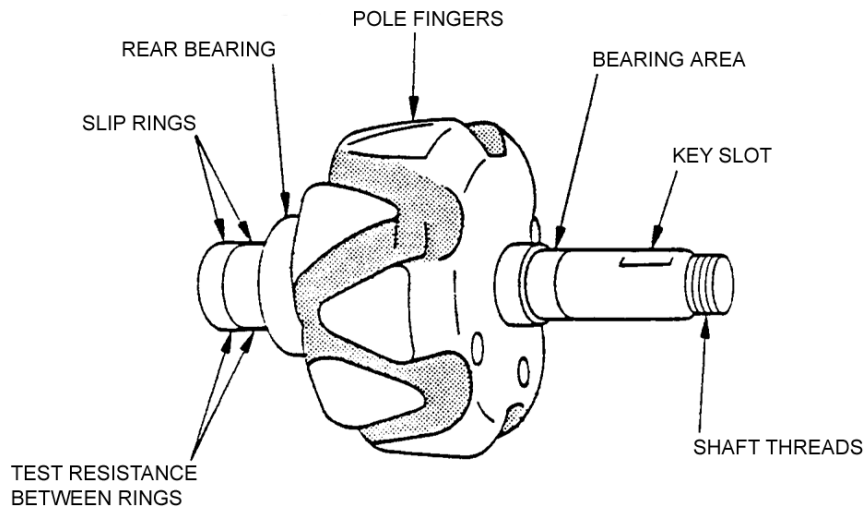

Figure 6. Rotor Test.

6. Inspect capacitors for evidence of overheating (burned wire/insulation).
7. Test capacitors as follows:
 - a. Using multimeter set for ohms, connect multimeter leads to capacitor wire lugs. Note ohms indication on multimeter.
 - b. Reverse multimeter leads on capacitor wire lugs. Note ohms indication on multimeter.
 - c. Resistance (ohms) readings should be high in one direction and low in the other. If readings are high or low in both directions, capacitor is defective and must be replaced.

END OF TASK

ASSEMBLY

1. If removed, install diodes and capacitors. Refer to WP 0093, Installation.
2. If removed, install bearings. Refer to WP 0092, Installation.
3. If removed, carefully fit rotor shaft through front housing (Figure 2).
4. Install new brush holder with brushes by aligning holder to mounting holes with arm over tie point. Ensure that lower brush lead is captured under right side mounting stud.
5. Secure brush holder with two nuts and washers.
6. Install three stator leads as tagged to heat sink terminals. Secure with nuts and remove tags.
7. Insert a straight pin (straightened paper clip, for example) through brush access hole in rear housing to retain brushes (see Figure 3 for location of brush access hole).
8. Align rear housing with rotor and front housing match marks and carefully press components together. Then install thru bolts and lockwashers. Remove straight pin retaining brushes.
9. Position bushing (Figure 2), fan, and key on rotor shaft.
10. Apply locking compound (WP 0162, Table 1, Item 7) to nut, then install drive pulley, lockwasher and nut. Hold rotor shaft with Allen wrench and torque nut from 55 to 70 ft•lb (75 to 95 N•m).
11. Apply locking compound (WP 0162, Table 1, Item 7) to threads of setscrews, torque setscrews to 50 in•lb. (5.6 N•m) to secure drive pulley.
12. If removed, install insulators, washers, nuts, and tie bar on positive terminals.

END OF TASK

INSTALLATION

1. If crankshaft adapter (Figure 1) was removed, clean engine crankshaft with isopropyl alcohol (WP 0151, Item 13) to remove old retaining compound and let dry. Otherwise proceed to Step 4.
2. Apply retaining compound (WP 0162, Table 1, Item 8) to the surface of engine crankshaft, and position new crankshaft adapter on crankshaft.
3. Apply locking compound (WP 0162, Table 1, Item 7) to threads of new screw and install screw with countersunk washer to secure crankshaft adapter. Torque screw to 22 ft•lb (29.8 N•m).
4. Install new machine key in slot of crankshaft adapter and position flexible flange coupling on adapter. Do not tighten setscrews.
5. Install engine adapter on engine with washers, lockwashers, and capscrews.
6. Install alternator with flexible sleeve coupling. Ensure that external teeth on flexible sleeve coupling engage the internal teeth of flexible flange couplings. Then secure alternator to engine adapter with capscrews, washers, and new self-locking nuts. Ensure ground strap is positioned under right side capscrew and washer. Torque self-locking nuts to 31 ft•lb (42 N•m). Connect electrical leads and remove tags.
7. Apply locking compound (WP 0162, Table 1, Item 7) to threads of setscrews for flexible flange coupling on crankshaft, pull coupling toward alternator until a gap of 0.625+0.031-0 in. (15.875+0.787-0 mm) is obtained between the two flexible flange couplings, and torque setscrews to 50 in•lb. (5.6 N•m).

8. Install guard with washers, lockwashers, and capscrews.
9. Install control panel. Refer to WP 0032, Installation.

END OF TASK

END OF WORK PACKAGE

FIELD MAINTENANCE**2 kW MEP-501A/531A MILITARY TACTICAL GENERATOR SETS****DC ALTERNATOR BEARINGS (MEP-501A): INSPECTION, REMOVAL, INSTALLATION**

INITIAL SETUP:**Tools and Special Tools**

Tool Kit, General Mechanic's Automotive or Standard Automotive Tool Set (WP 0159, Table 2, Item 6)
Shop Equipment, Automotive Maintenance and Repair, Field Maintenance, Suppl 1 W/O Power (WP 0159, Table 2, Item 4)

Materials/Parts

Isopropyl Alcohol (WP 0162, Table 1, Item 13)
Compound, Locking (WP 0162, Table 1, Item 7)
Grease, General (WP 0162, Table 1, Item 12)

Equipment Condition

Generator set shut down (WP 0005, Stopping Procedure)
Cable disconnected for NATO Slave Receptacle (WP 0005)

INSPECTION

1. Disassemble alternator assembly. Refer to WP 0091, Disassembly.
2. Inspect bearings for wear.
3. Assemble alternator assembly. Refer to WP 0091, Assembly.

END OF TASK**REMOVAL**

1. Disassemble alternator assembly. Refer to WP 0091, Disassembly.
2. If necessary, using wheel puller, remove rotor bushing (Figure 1).
3. Remove screws and washers securing front bearing. Using suitable press, press front bearing out of front housing.
4. Using suitable press, press rear bearing and dust cap out of rear housing using a dowel with a diameter slightly less than outer race of rear housing bearing.
5. Clean bearing cavities in front and rear housings with isopropyl alcohol (WP 0162, Table 1, Item 13).
6. Apply light coating of general purpose grease (WP 0162, Table 1, Item 12) to each bearing cavity.

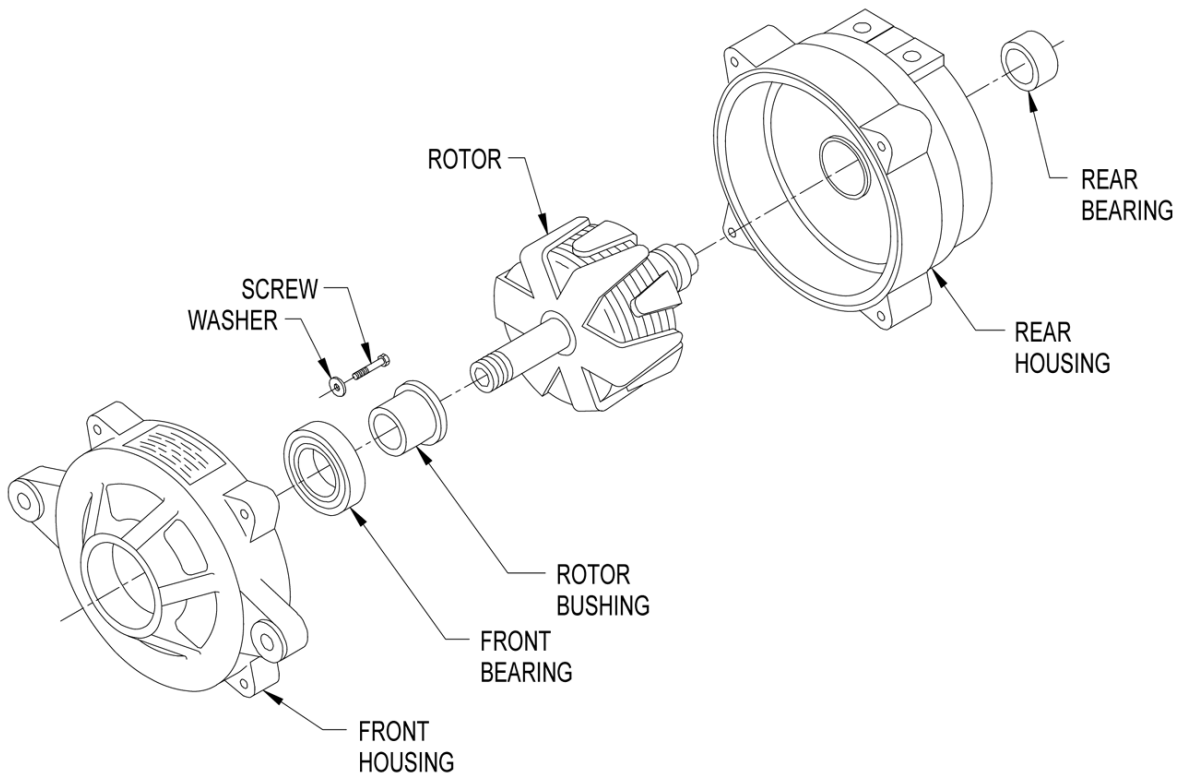

Figure 1. Alternator Bearing Replacement.

END OF TASK

INSTALLATION

1. Press new front bearing into front housing (Figure 1).
2. Install rotor bushing. Apply locking compound (WP 0162, Table 1, Item 7) to threads of screws. Then install screws with washers. Torque screws 60 to 65 in•lb. (6.8 to 7.3 N•m).
3. Press new rear bearing into rear housing. Then install dust cap.
4. Assemble alternator assembly. Refer to WP 0091, Assembly.

END OF TASK

END OF WORK PACKAGE

FIELD MAINTENANCE**2 kW MEP-501A/531A MILITARY TACTICAL GENERATOR SETS****DC ALTERNATOR DIODES AND CAPACITORS (MEP-501A): REMOVAL, TESTING, INSTALLATION**

INITIAL SETUP:**Tools and Special Tools**

Tool Kit, General Mechanic's Automotive or Standard Automotive Tool Set (WP 0159, Table 2, Item 6)
Shop Equipment, Automotive Maintenance and Repair, Field Maintenance, Suppl 1 W/O Power (WP 0159, Table 2, Item 4)
Multimeter (WP 0159, Table 2, Item 3)

Materials/Parts

As required

Equipment Condition

Generator set shut down (WP 0005, Stopping Procedure)
Cable disconnected for NATO Slave Receptacle (WP 0005)

REMOVAL

1. Remove four socket head screws (WP 0091, Figure 2) and carefully separate rear housing with stator from rotor and front housing.
2. Remove brush holder and lift off capacitor leads (Figure 1).
3. Tag stator leads. Then remove nuts from heat sink terminals (6 places) and carefully separate stator from rear housing.
4. Tag ends of capacitors. Then remove screws and lockwashers securing capacitors to heat sink and remove capacitors.
5. Tag and disconnect diode leads from heat sink terminals.
6. Remove bolts and spacers securing positive heat sinks to rear housing. Retain all insulators.
7. Lift positive heat sinks from rear housing. Ensure tie point insulators remain in place.
8. Remove screws with spacers securing negative heat sink to rear housing.
9. Using a suitable press and short hardwood dowel, remove defective diodes.

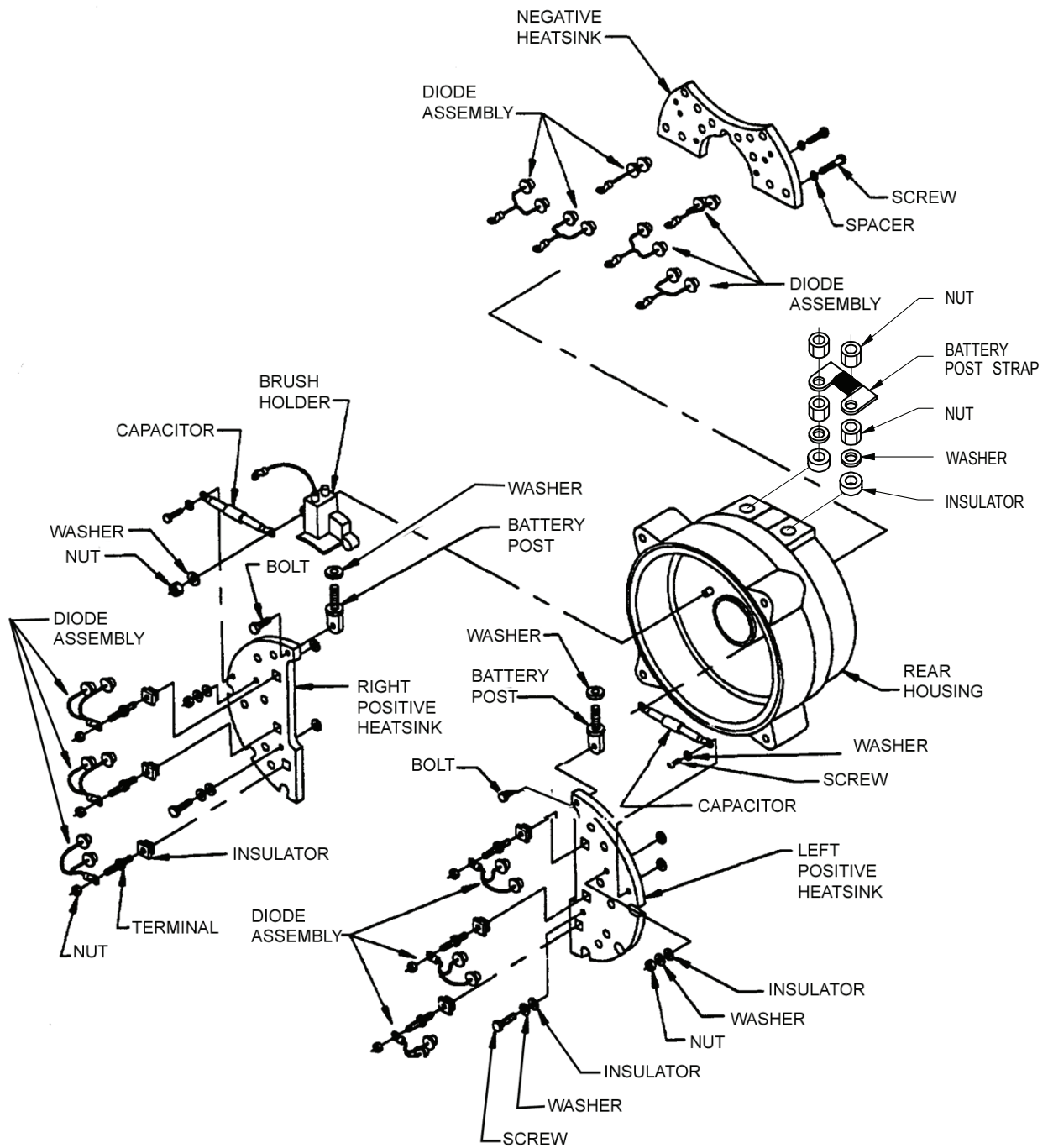

Figure 1. Diodes and Capacitor Replacement.

END OF TASK

TESTING

1. Using multimeter set for ohms, connect multimeter leads to diode wire lugs. Note ohms indication on multimeter.
2. Reverse multimeter leads on diode wire lugs. Note ohms indication on multimeter.

3. Resistance (ohms) readings should be high in one direction and low in the other. If readings are high or low in both directions, diode is defective and must be replaced.
4. Repeat Steps 1, 2, and 3 for each of the other diodes.
5. Inspect capacitors for evidence of overheating (burned wire/insulation).
6. Using multimeter set for ohms, connect multimeter leads to capacitor wire lugs. Note ohms indication on multimeter.
7. Reverse multimeter leads on capacitor wire lugs. Note ohms indication on multimeter.
8. Resistance (ohms) readings should be high in one direction and low in the other. If readings are high or low in both directions, capacitor is defective and must be replaced.

END OF TASK

INSTALLATION

1. Install new lugs on each diode clipped during removal. Ensure that leads are long enough to reach tie points (Figure 1).
2. Using suitable press, install replacement diodes into heat sinks.
3. Install negative heat sink on outside of rear housing and secure with screws and spacers.
4. Install positive heat sinks in inside of rear housing and secure with bolts and spacers. Ensure that negative diode leads are routed as tagged.
5. Install new brush holder with brushes by aligning holder to mounting holes with arm over tie point. Ensure that lower brush lead is captured under right side mounting stud.
6. Secure brush holder with nuts and washers.

NOTE

Install a new capacitor so that positive end of capacitor is connected under brush.

7. Install capacitors as tagged and secure with screws and washers. Remove tags.
8. Assemble alternator assembly. Refer to WP 0091, Assembly.
9. Tighten nuts securing positive terminals to rear housing. Install capacitor leads. Install battery post strap and secure with nylon locknuts.

END OF TASK

END OF WORK PACKAGE

FIELD MAINTENANCE**2 kW MEP-501A/531A MILITARY TACTICAL GENERATOR SETS****FRAME: INSPECTION, REMOVAL, REPAIR, INSTALLATION**

INITIAL SETUP:**Tools and Special Tools**

Tool Kit, General Mechanic's Automotive or Standard Automotive Tool Set (WP 0159, Table 2, Item 6)

Materials/Parts

Paper, Abrasive (WP 0162, Table 1, Item 17)

References

WP 0022, ENGINE RESILIENT MOUNTS REPLACEMENT: Removal, and Installation
WP 0029, FUEL TANK ASSEMBLY: Removal, and Installation
WP 0032, CONTROL PANEL ASSEMBLY: Removal, and Installation
WP 0070, ENGINE WIRING HARNESS: Removal, and Installation
WP 0071, ALTERNATOR WIRING HARNESS (MEP-501A): Removal, and Installation
WP 0078, ENGINE/ALTERNATOR ASSEMBLY: Removal, and Installation
WP 0162, EXPENDABLE AND DURABLE ITEMS LIST
TM 43-0139/TO 35-1-3

Equipment Condition

Generator set shut down (WP 0005, Stopping Procedure)
Cable disconnected for NATO Slave Receptacle (WP 0005)
Engine/Alternator Assembly removed (WP 0078)

WARNING

Chemical Agent Resistant Coating (CARC) paint dust is a health hazard. Wear protective eyewear, mask, and gloves when sanding CARC painted surfaces. Failure to comply can cause personal injury.

INSPECTION

1. Inspect frame (Figure 1) for chipped paint, and other damage.
2. Inspect threaded inserts for debris and damage.

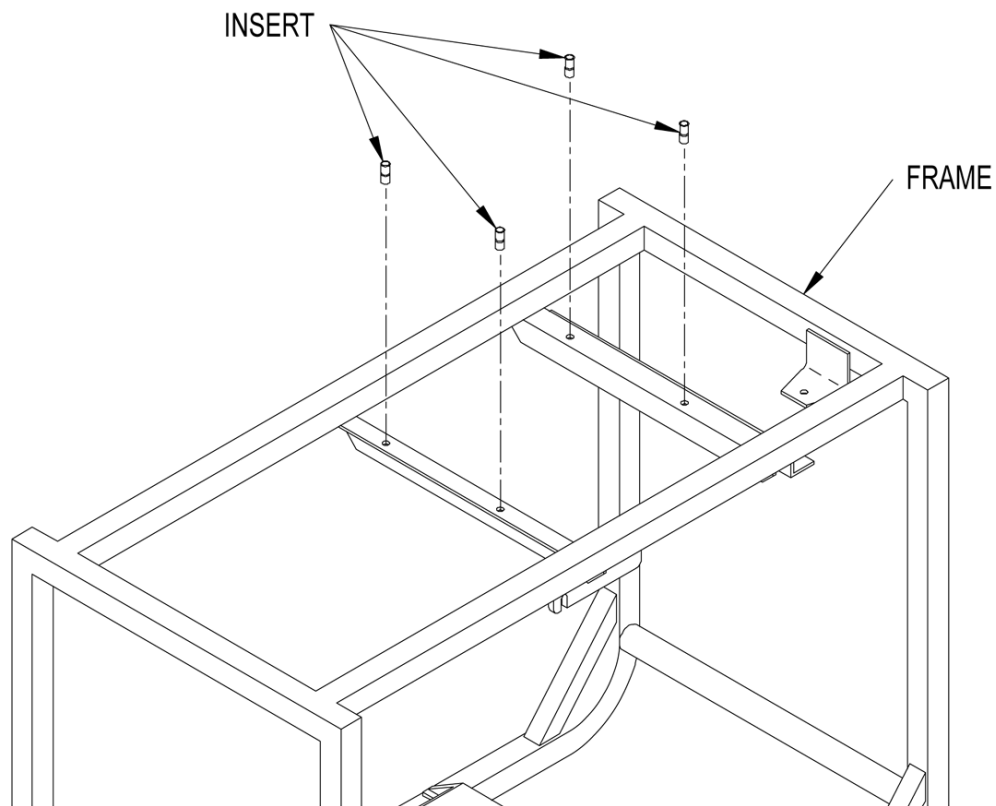

Figure 1. Frame.

END OF TASK

REMOVAL

1. Remove control panel assembly. Refer to WP 0032, Removal.
2. Remove fuel tank and piping. Refer to WP 0029, Removal.
3. Remove engine harness assembly. Refer to WP 0070, Removal.
4. Remove alternator harness assembly (MEP-501A). Refer to WP 0071, Removal.
5. Remove diesel engine and alternator assembly. Refer to WP 0078, Removal.
6. Remove diesel engine resilient mounts. Refer to WP 0022, Removal.

END OF TASK

REPAIR

1. Repair all dents and cracks. Replace damaged threaded inserts. Remove all loose paint.
2. Remove light corrosion with fine grit abrasive paper (WP 0162, Table 1, Item 17).
3. Repaint surface in accordance with TM 43-0139/TO 35-1-3.

END OF TASK

INSTALLATION

1. Install diesel engine resilient mounts. Refer to WP 0022, Installation.
2. Install diesel engine and alternator assembly. Refer to WP 0078, Installation.
3. Install alternator harness assembly (MEP-501A). Refer to WP 0071, Installation.
4. Install engine harness assembly. Refer to 0070, Installation.
5. Install fuel tank and piping. Refer to WP 0029, Installation.
6. Install control panel assembly. Refer to WP 0032, Installation.

END OF TASK**END OF WORK PACKAGE**

FIELD MAINTENANCE

2 KW MEP-501A/531A MILITARY TACTICAL GENERATOR SETS

2 KW DEPROCESSING CHECKLIST

INITIAL SETUP:**Tools and Special Tools**

Tool Kit, General Mechanic's Automotive or Standard Automotive Tool Set (WP 0159, Table 2, Item 6)

References

WP 0004, Figure 1, Sheet 2, Meters
 WP 0004, Figure 1, Item 8, Crankcase Oil
 WP 0005, Operation Under Usual Conditions
 WP 0005, Figure 8
 WP 0010, Operator Level PMCS
 WP 0011, Figure 1, Instrument Fuse (F1)
 WP 0018, Figure 1, Air Filter Element Replacement
 WP 0027, Figure 1, Fuel Filter Assembly
 WP 0028, Figure 1, item 14, Fuel Drain Cock
 WP 0029, Figure 1, Items 8 and 10, Fuel Tank Assembly, Brackets
 WP 0029, Figure 1, Item 11, Fuel Tank Assembly, Guard
 WP 0031, Figure 1, Exhaust System Components
 WP 0034, Figure 1, Instrument Cover
 WP 0040, Figure 1, VOLTAGE ADJ. Potentiometer
 WP 0045, Figure 1, Ground Strap(s)
 WP 0046, Figure 1, GFCI Receptacle and Receptacle Cover (MEP-531A)
 WP 0047, Figure 1, START-PREHEAT/PREHEAT/OFF/START Rotary Switch
 WP 0049, Figure 2, NATO slave receptacle
 WP 0050, Figure 1, Load Terminal(s) (MEP-501A and Mechron Sets)
 WP 0053, Figure 1, ON-OFF Load Circuit Breaker Assembly and Boot
 WP 0057, Figure 1, Electrical Lead Wire(s) (Typical)
 WP 0058, Figure 1, Load Terminal Board Cover (Lug Cover)
 WP 0060, Figure 1, Low Oil Pressure (LOP) Switch
 WP 0062, Figure 1, Low Oil Pressure (LOP) Engine Shutdown Cable
 WP 0064, Figure 1, Governor Regulator Bracket (run/stop controls)
 WP 0066, Figure 1, Recoil Starter Assembly
 WP 0069, Figure 1, Starter Assembly (MEP-501A)
 WP 0073, Figure 1, Ground Stud Terminal
 WP 0089, Figure 1, AC Alternator Assembly (MEP-531A)
 WP 0094, Figure 1, Frame
 WP 0097, Figure 2, DC Alternator Assembly (MEP-501A)

Materials/Parts

Fuel DL-1, DL-2, or JP8
 Lubricating oil GR OEA, GR OE/HD-15, GR OE/HDO-10, GR OE/HDO-30 or GR OE/HDO-40
 Ground rod NSN 5975-00-878-3791
 Ground cables 6 AWG min.
 Tool kit NSN 5180-00-177-7033
 Container Suitable for excess fuel
 Cloth For fuel spilling
 Load bank
 Hearing protection
 24 VDC battery source (for cold weather starting)

Equipment Condition

Generator set shut down (WP 0005, Stopping Procedure)
 Cable disconnected for NATO Slave Receptacle (WP 0005)
 Engine/Alternator Assembly removed (WP 0078)

WARNING

Exhaust discharge contains deadly gases. Do not operate generator set in enclosed area unless exhaust discharge is properly vented outside. Position as far away from personnel, shelters, and occupied vehicles as possible. Failure to observe this warning could result in severe personal injury or death due to carbon monoxide poisoning.

WARNING

MEP-531A engine/alternator assembly weighs 100 lbs (45.4 kg). MEP-501A engine/alternator assembly weighs 80 lbs (36.2 kg). Use caution when removing assembly to prevent personal injury.

For use of this checklist, see the Deprocessing check sheet.

NOTE

This generator set can operate on DL- 1, DL- 2 & JP-8.
No adjustments are necessary to run these alternate fuels.

Required Items:

Fuel	DL-1, DL-2, or JP8
Lubricating oil	GR OEA, GR OE/HD-15, GR OE/HDO-10, GR OE/HDO-30 or GR OE/HDO-40
Ground rod	NSN 5975-00-878-3791
Ground cables	6 AWG min.
Tool kit	NSN 5180-00-177-7033
Container	Suitable for excess fuel
Cloth	For fuel spilling
Load bank	
Hearing protection	
24 VDC battery source	(for cold weather starting)

Checklist:

- _____ Packaging material
- _____ Identification plate
- _____ Frame
- _____ Control panel
- _____ Before Preventive Maintenance Checks and Services
- _____ During Preventive Maintenance Checks and Services
- _____ After Preventive Maintenance Checks and Services

DEPROCESSING CHECKSHEET**WARNING**

Exhaust discharge contains deadly gases. Do not operate generator set in enclosed area unless exhaust discharge is properly vented outside. Position as far away from personnel, shelters, and occupied vehicles as possible. Failure to observe this warning could result in severe personal injury or death due to carbon monoxide poisoning.

WARNING

Generator sets weight 123 to 144 lbs. Use suitable lifting device or four-man lift.

WARNING

Place the generator set on a level site if possible. Provide enough clearance around the generator set to allow for normal operation and maintenance functions.

1. Deprocessing Inspection

TM 9-6115-673-13&P is the source reference unless otherwise noted.

- a. Remove all packaging material.
- b. Inspect identification plate for positive identification of generator set. (WP 0005, Figure 8)
- c. At a minimal inspect the following items on the generator set for missing hardware, looseness or any damage that may have occurred during shipment.

Frame:

- Ground Strap(s) (WP 0045, Figure 1)
- Ground Stud Terminal (WP 0073, Figure 1)
- Frame (WP 0094, Figure 1)

Control Panel exterior and interior:

- Meters (WP 0004, Figure 1, Sheet 2)
- Instrument Cover (WP 0034, Figure 1)
- VOLTAGE ADJ. Potentiometer (WP 0040, Figure 1)
- Instrument Fuse (F1) (WP 0011, Figure 1)
- GFCI Receptacle and Receptacle Cover (MEP-531A) (WP 0046, Figure 1)
- START-PREHEAT/PREHEAT/OFF/START Rotary Switch (WP 0047, Figure 1)
- NATO slave receptacle (WP 0049, Figure 2)
- Load Terminal(s) (MEP-501A and Mechron Sets) (WP 0050, Figure 1)
- ON-OFF Load Circuit Breaker Assembly and Boot (WP 0053, Figure 1)
- Electrical Lead Wire(s) (Typical) (WP 0057, Figure 1)
- Load Terminal Board Cover (Lug Cover) (WP 0058, Figure 1)

Alternator:

- Ground Strap(s) (WP 0045, Figure 1)
- AC Alternator Assembly (MEP-531A) (WP 0089, Figure 1)/ DC Alternator Assembly (WP 0097, Figure 2)

Engine:

- Fuel Filter Assembly (WP 0027, Figure 1)
- Air Filter Element Replacement (WP 0018, Figure 1)
- Exhaust System Components (WP 0031, Figure 1)
- Low Oil Pressure (LOP) Switch (WP 0060, Figure 1)
- Low Oil Pressure (LOP) Engine Shutdown Cable (WP 0062, Figure 1)
- Governor Regulator Bracket (run/stop controls) (WP 0064, Figure 1)
- Recoil Starter Assembly (WP 0066, Figure 1)
- Starter Assembly (MEP-501A) (WP 0069, Figure 1)

Fuel Tank:

- Fuel Tank Assembly, Brackets (WP 0029, Figure 1, Items 8 and 10)
- Fuel Drain Cock (WP 0028, Figure 1, item 14)
- Fuel Tank Assembly, Guard (WP 0029, Figure 1, Item 11)

2. Deprocessing Servicing

- a. Perform BEFORE Operations (WP 0010, Operator Level PMCS).

- Item 1: Control panel, Instrument panel
- Item 2: Ground terminal stud (WP 0005 for installation of ground rod)
- Item 3: Identification and Instruction Plates
- Item 4: Load terminals (WP 0005 for placement of load cables)
- Item 5: Air Intake Cover Wing Nut
- Item 6: Filter Assembly, Fuel (Use WP 0005 for priming and bleeding the fuel system.)
- Item 7: Fuel system; use the required fuel for the operating environment.
- Item 8: Crankcase Oil (WP 0004, Figure 1, Item 8) Use the required oil for the operating environment.
- Item 9: Cylinder head cooling fins and recoil starter cover.
- Item 10: Spark arrester.

- b. Perform DURING Operations (WP 0010, Operator Level PMCS). Follow the Initial adjustment and checks/operating procedures to operate the set, placement of the intake cover and limitation of load (75%) (WP 0005, Initial Adjustments, Before Use and Self-Test, Initial Adjustments and Checks). Operate the generator set 15 minutes minimum to ensure that no leaks are detected, and a load can be drawn.

- Item 1: Instrument Panel
- Item 4: Ground Terminal Stud
- Item 7: Fuel system
- Item 8: Crankcase Oil
- Item 9: Cylinder head cooling fins and recoil starter cover.

- c. Perform AFTER Operations (WP 0010, Operator Level PMCS). To stop the generator set, follow Stopping Procedure (WP 0005, Stopping Procedure).

- Item 1: Instrument Panel
- Item 2: Identification and Instruction Plates
- Item 6: Filter Assembly, Fuel
- Item 7: Fuel System
- Item 8: Crankcase Oil
- Item 9: Cylinder head cooling fins and recoil starter cover.

3. Quality Deficiency Report (QDR)

Develop a QDR on any deficiencies, which prevent operational capabilities from being achieved.

END OF WORK PACKAGE

FIELD MAINTENANCE

2 kW MEP-501A/531A MILITARY TACTICAL GENERATOR SETS

DEWEY/MECHRON CROSS-REFERENCE LIST

INITIAL SETUP:

Not Applicable

Table 1. MEP-531A Cross-Reference List for Component Identifiers.

DEWEY	MECHRON	DESCRIPTION
A1	VR109	VOLTAGE REGULATOR, 120 V, 60 Hz
A2	UA117	GENERATOR, CONTROL CIRCUIT
B1	B123	MOTOR, STARTER, PART OF ENGINE
CB1	CB104	CIRCUIT BREAKER, SINGLE POLE, SHUNT, AUX
CR1	D125	DIODE
CR2	D110	DIODE
F1	F102	FUSE
F1A	F102A	FUSE, SPARE
G1	UA121	DYNAMO
G2	UA102	ALTERNATOR, 120 VAC
HTR1	HR112a	HEATER, ENGINE PREHEAT
HTR2	HR112b	HEATER, ENGINE PREHEAT
J1	J104	CONNECTOR, RECEPTACLE, ELECTRICAL
J2	J124	CONNECTOR, RECEPTACLE, ELECTRICAL
J3	RP107	RECEPTACLE, GROUND FAULT
L	L1	TERMINAL, LINE 120 V, 60 Hz
L4	SOL116	SOLENOID, LOW OIL PRESSURE
L5	SOL124	SOLENOID, STARTER MOTOR, PART OF ENGINE
M1	M102	AMMETER
M2	M104	VOLTMETER, AC
M3	M103	METER, TIME TOTALIZING
M4	M105	METER, FREQUENCY
N	N	TERMINAL, NEUTRAL
P1	P104	CONNECTOR, PLUG, ELECTRICAL 90 DEG
P2	P124	CONNECTOR, PLUG, ELECTRICAL 90 DEG
R2	RH109	POTENTIOMETER, VOLTAGE ADJUSTMENT
S1	S115	SWITCH, LOW OIL PRESSURE
S2	S121	SWITCH, ROTARY, FOUR-POSITION
SR1	RP123	RECEPTACLE, SLAVE, 24 VDC, EXTERNAL SUPPLY

Table 1. MEP-531A Cross-Reference List for Component Identifiers. - Continued

DEWEY	MECHRON	DESCRIPTION
TB1	TB1	TERMINAL BOARD
V1	RV123	VARISTOR, DISCHARGE
XF1	F102	FUSEHOLDER
XF1A	F102A	FUSEHOLDER, SPARE

Table 2. MEP-531A Cross-Reference List for Wiring Identifiers.

DEWEY		MECHRON		
FROM	TO	WIRE NO.	FROM	TO
A1-4	TB1-15	4	VR109-4	TB1-15
A1-3/F+	TB1-8	3/F+	VR109-3/F+	TB1-8
A1-E1	TB1-13	E1	VR109-E1	TB1-14
A1-F-	TB1-9	F-	VR109-F-	TB1-9
A1-HZ	NC	HZ	VR109-HZ	NC
A1-HZ	NC	HZ	VR109-HZ	NC
A1-VAR	TB1-11	VAR	VR109-VAR	TB1-11
A1-VAR	TB1-12	VAR	VR109-VAR	TB1-12
A2-F	NC	21	UA117-F0	NC
A2-GND	TB1-1	GND	UA117-GND	TB1-1
A2-LOP SOL	TB1-4	7	UA117-LOP SOL	TB1-4
A2-LOP SW	TB1-3	6	UA117-LOP SW	TB1-3
A2-STC	TB1-7	11	UA117-STC	TB1-7
A2-VINAC	TB1-10	57	UA117-VINAC	TB1-10
A2-VINDC	NC	20	UA117-VINDC	NC
A2-VMAG+	TB1-2	4	UA117-VMAG+	TB1-2
A2-VMAG1	TB1-5	8	UA117-VAMG1	TB1-5
A2-VMAG2	TB1-6	9	UA117-VMAG2	TB1-6
B1	L5	-	R123	SOL124
CB1-A(LINE)	M1	57	CB104	M102
CB1-A(LINE)	TB1-10	57	CB104	TB1-10
CB1-B(LOAD)	FL1-L	59	CB104	L1
CB1-C	CR2	-	CB104	D103
CB1-COM	TB1-2	4	CB104-COM	TB1-2
CB1-D	CR2	-	CB104	D103
CB1-NO	CR2	12	CB104-NO	D103
CR1	S2-S	3	D125	S121-S
CR1	TB1-1	GND	D125	TB1-1

Table 2. MEP-531A Cross-Reference List for Wiring Identifiers. - Continued

DEWEY		MECHRON		
FROM	TO	WIRE NO.	FROM	TO
CR2	TB1-7	11	D103	TB1-7
E1	FL1-N	GND	GND STUD	N
E1	SR1 (-)	GND	GND STUD	RP123
E1	TB1-1	GND	GND STUD	TB1-1
E1	J3-GR	GND	GND STUD	RP107a,b
G1	P2-E	8	UA121	P124-E
G1	P2-F	9	UA121	P124-F
G2 (+)	P1-E	55	UA102 (+)	P104-E
G2 (-)	P1-F	56	UA102 (-)	P104-F
G2-1	P1-A	51	UA102-1	P104-A
G2-2	P1-B	52	UA102-2	P104-B
G2-3	P1-C	53	UA102-3	P104-C
G2-4	P1-D	54	UA102-4	P104-D
HTR1	HTR2	5	HR112a	HR112b
HTR1	GND	13	HR112a	GND
HTR2	P2-A	10	HR112b	P124-A
J1-A	TB1-13	51	J104-A	M102
J1-B	FL1-N	52	J104-B	N
J1-C	TB1-14	53	J104-C	TB1-14
J1-D	TB1-15	54	J104-D	TB1-15
J1-E	TB1-8	55	J104-E	TB1-8
J1-F	TB1-9	56	J104-F	TB1-9
J2-A	S2-H	10	J124-A	S121-H
J2-B	TB1-3	6	J124-B	TB1-3
J2-C	S2-S	3	J124-C	S121-S
J2-D	SR1 (+)	1	J124-D	RP123 (+)
J2-E	TB1-5	8	J124-E	TB1-5
J2-F	TB1-6	9	J124-F	TB1-6
J3-HOT	FL1-L	59	RP107a,b	L1
J3-NEUT	FL1-N	N	RP107a,b	N
L4-R	TB1-2	4	SOL116	TB1-2
L4-Y	TB1-4	7	SOL116	TB1-4
L5-C	P2-C	3	SOL124	P124-C
L5-S	P2-D	1	SOL124	P124-D
M1	TB1-14	51	M102	TB1-14
M2-1	M4-1	N	M104	M105

Table 2. MEP-531A Cross-Reference List for Wiring Identifiers. - Continued

DEWEY		MECHRON		
FROM	TO	WIRE NO.	FROM	TO
M2-2	FL1-N	N	M105	N
M2-2	M4-2	N	M104	M105
M3(+)	TB1-2	4	M103	TB1-2
M3(-)	E1	GND	M103	GND STUD
FL1-N	TB1-15	N	N	TB1-15
P2-B	S1	6	P124-B	S115
R2	TB1-11	63	RH109	TB1-11
R2	TB1-12	64	RH109	TB1-12
S2-B	SR1(+)	1	S121-B	RP123
TB1-13	TB1-14		TB1-13	TB1-14
V1	TB1-5		RV123	TB1-5
V1	TB1-6		RV123	TB1-6
XF1	M2-1	60	F102	M104/M105
XF1	M1	51	F102	M102
		60	M105	F102

Table 3. MEP-501A Cross-Reference List for Component Identifiers.

DEWEY	MECHRON	DESCRIPTION
-ve	-ve	TERMINAL, NEGATIVE
+ve	+ve	TERMINAL, POSITIVE
A1	VR109	VOLTAGE REGULATOR, 24 VOLT
A2	UA117	CONTROL, GENERATOR
B1	B123	MOTOR, STARTER, 24 VDC, PART OF ENGINE
C1	C110	CAPACITOR, 1000 F, 63 VDC
CB1	CB104	CIRCUIT BREAKER, 2-POLE
CR1	D125	DIODE
CR2	D110	DIODE
CR3	D109	DIODE
E1	GND	CHASSIS CONNECTION
E2	GND(G2)	CHASSIS CONNECTION
E3	GND(ENG)	CHASSIS CONNECTION
E4	GND(HTR)	CHASSIS CONNECTION
F1	F102	FUSE
F1A	F102A	FUSE, SPARE
G1	UA121	DYNAMO

Table 3. MEP-501A Cross-Reference List for Component Identifiers. - Continued

DEWEY	MECHRON	DESCRIPTION
G2	UA102	GENERATOR, 28 VDC
HTR1	HR112a	HEATER, PREHEAT
HTR2	HR112b	HEATER, PREHEAT
J1	J104	CONNECTOR, RECEPTACLE, ELECTRICAL 90
J2	J124	CONNECTOR, RECEPTACLE, ELECTRICAL 90
L4	SOL116	SOLENOID, LOW OIL PRESSURE
L5	SOL124	SOLENOID, STARTER MOTOR
M1	M102	AMMETER
M2	M104	VOLTMETER, DC
M3	M103	METER, TIME TOTALIZING
P1	P104	CONNECTOR, PLUG, ELECTRICAL 90
P2	P124	CONNECTOR, PLUG, ELECTRICAL 90
R1	R102	RESISTOR, POWER, 20 OHMS, 50 W, 1%
R2	RH109	POTENTIOMETER, VOLTAGE ADJUSTMENT
R3	SH104	RESISTOR, SHUNT, 0-89.3A
S1	S115	SWITCH, LOW OIL PRESSURE
S2	S121	SWITCH, ROTARY, FOUR-POSITION
SR1	RP123	RECEPTACLE, SLAVE, 24 VDC, EXTERNAL SUPPLY
TB1	TB1	TERMINAL BOARD
V1	RV123	VARISTOR, DISCHARGE
XF1	F102	FUSEHOLDER
XF1A	F102A	FUSEHOLDER

Table 4. MEP-501A Cross-Reference List for Wiring Identifiers.

DEWEY		MECHRON		
FROM	TO	WIRE NO.	FROM	TO
A1-1	TB1-12	25	VR109-1	TB1-12
A1-2	TB1-13	26	VR109-2	TB1-13
A1-L	TB1-11	22	VR109-L	TB1-11
A1-F-	TB1-10	21	VR109-F-	TB1-10
A1-S	TB1-9	20	VR109-S	TB1-9
A1-A	TB1-8	20	VR109-A	TB1-8
A1-GND	TB1-2		VR109-GND	TB1-2
A2-STC	TB1-8	11	UA	TB1-8
A2-GND	TB1-1	GND	UA117-GND	TB1-1
A2-VINAC	NC	57	UA117-VINAC	NC

Table 4. MEP-501A Cross-Reference List for Wiring Identifiers. - Continued

DEWEY		MECHRON		
FROM	TO	WIRE NO.	FROM	TO
A2-VMAG2	TB1-7	9	UA117-VMAG2	TB1-7
A2-VMAG1	TB1-6	8	UA117-VMAG1	TB1-6
A2-VMAG+	TB1-3	4	UA117-VMAG+	TB1-3
A2-LOP SW	TB1-4	6	UA117-LOP SW	TB1-4
A2-LOP SOL	TB1-5	7	UA117-LOP SOL	TB1-5
A2-VINDC	TB1-9	20	UA117-VINDC	TB1-9
A2-F	TB1-10	21	UA117-F	TB1-10
B1	L5		B123	SOL124
CB1-P1(LINE)	R3	23	CB104	SH104
CB1-P1(LINE)	C1(+)	23	CB104	C110(+)
CB1-P2(LINE)	TB1-3	4	CB104	TB1-3
CB1-P1(LOAD)	+ve	1	+ve	CB104
CB1-P2(LOAD)	TB1-8	11	CB104	TB1-8
C1(-)	-ve	2	+ve	C110(-)
CR1	TB1-1	GND	D125	TB1-1
CR1	S2-S	3	D125	S2-S
CR2	CR3	14	D110	D109
CR2	-ve	2	D109	-ve
CR3	+ve	1	D109	+ve
E1	M3(-)	GND	GND STUD	M103
E1	SR1 (-)	GND	GND STUD	RP123
E1	TB1-1	GND	GND STUD	TB1-1
XF1	M2- (RED)	20	F102	M104
XF1	M1- (RED)	24	F102	M102
G1	P2-E	8	UA121	P124-E
G1	P2-F	9	UA121	P124-F
G2 (+)	P1-A	20	UA102-1	P104-A
G2-FLD	P1-B	21	UA102-2	P104-B
G2-STA	P1-D	22	UA102-3	P104-D
G2 (-)	P1-C	2	UA102-4	P104-C
G2 (+)	R1		UA102 (+)	R102
G2 (-)	R1	2	UA102 (-)	R102
HTR2	P2-A	10	HR112b	P124-A
J1-A	R3	20	J104-A	M102
J1-B	TB1-10	21	J104-B	NC
J1-C	-ve	2	J104-C	TB1-14

Table 4. MEP-501A Cross-Reference List for Wiring Identifiers. - Continued

DEWEY		MECHRON		
FROM	TO	WIRE NO.	FROM	TO
J1-D	TB1-11	22	J104-D	TB1-15
J2-A	S2-H	10	J124-A	S121-H
J2-B	TB1-4	6	J124-B	TB1-4
J2-C	S2-S	3	J124-C	S121-S
J2-D	SR1 (+)	1	J124-D	RP123 (+)
J2-E	TB1-6	8	J124-E	TB1-6
J2-F	TB1-7	9	J124-F	TB1-7
-ve	TB1-2	2	+ve	TB1-2
-ve	M2-BLK	2	+ve	M104
-ve	SR1(-)	2	+ve	RP123(-)
L4-Y	TB1-5	7	SOL116	TB1-5
L4-R	TB1-3	4	SOL116	TB1-3
L5-S	P2-D	1	SOL124	P124-D
L5-C	P2-C	3	SOL124	P124-C
M1-R	R3	20	M102	SH104
M1-BLK	R3	23	M102	SH104
R3	TB1-9	20	SH104	TB1-9
M3(+)	TB1-3	4	M103	CB104
P2-B	S1	6	P124-B	S115
R2	TB1-12	25	RH109	TB1-12
R2	TB1-13	26	RH109	TB1-13
S2-B	SR1 (+)	1	S121-B	CB104
V1	TB1-6		RV123	TB1-6
V1	TB1-7		RV123	TB1-7

END OF WORK PACKAGE

FIELD MAINTENANCE

2 kW MEP-501A/531A MILITARY TACTICAL GENERATOR SETS

ELECTRICAL LEAD FABRICATION FOR CONTROL PANEL

INITIAL SETUP:

Not Applicable

Table 1. Electrical Lead Fabrication for Control Panel (MEP-531A).

TERMINATION		WIRE BULK NO.	"FROM" TERMINAL END	"TO" TERMINAL END	WIRE LENGTH in. [mm]	ELECTRICAL LEAD NO.
FROM	TO					
M1	XF1	M16878/3BJE-9	BB-837-10	640919-1	12.25 [311.15]	95-8166-1
XF1	M2-1	M16878/3BJE-9	640919-1	BB-837-10	11.50 [292.10]	95-8166-2
M2-1	M4-1	M16878/3BJE-9	BB-837-10	BB-837-10	2.75 [69.85]	95-8166-3
TB1-2	M3 (+)	M16878/3BJE-9	P14-6R	RB2573	23.50 [596.90]	95-8166-4
M2-2	FL1-N*	M16878/3BJE-9	BB-837-10	BB-825-14	22.50 [571.50]	95-8166-5
M2-2	M4-2	M16878/3BJE-9	BB-837-10	BB-837-10	2.75 [69.85]	95-8166-6
E1	M3 (-)	M16878/3BJE-9	BB-825-14	RB2573	29.00 [736.60]	95-8166-7
E1	TB1-1	M16878/3BJE-9	BB-825-14	P14-6R	9.75 [247.65]	95-8166-8
TB1-10	CB1-A (LINE)	M16878/3BJE-9	P14-6R	BB-837-10	8.75 [222.25]	95-8166-9
TB1-14	M1	M16878/3BKE-9	P14-6R	BB-837-10	31.25 [793.75]	95-8166-10
TB1-15	FL1-N*	M16878/3BKE-9	P14-6R	BB-825-14	12.75 [323.85]	95-8166-11
J3-GR	E1	M16878/3BKE-9	BB-8194-08	BB-825-14	21.00 [533.40]	95-8166-12
FL1-N*	E1	M16878/3BKE-9	BB-825-14	BB-825-14	11.50 [292.10]	95-8166-13
M1	CB1-A (LINE)	M16878/3BKE-9	BB-837-10	BB-837-10	32.75 [831.85]	95-8166-14
CB1-B (LOAD)	FL1-L*	M16878/3BKE-9	BB-837-10	BB-825-14	15.00 [381.00]	95-8166-15
J3-HOT	FL1-L*	M16878/3BKE-9	BB-8194-08	13230E4455-2 (MEP-531A) BB-825-14 (Mechron 120 VAC)	21.50 [546.10]	95-8166-16
S2-B	SR1 (+)	M16878/3BNL-9	PV8-10R	PV8-38R	8.00 [203.20]	95-8166-17
J3-NEUT	FL1-N*	M16878/3BKE-9	BB-8194-08	RB2573 (MEP-531A) BB-825-14 (Mechron 120 VAC)	18.50 [469.90]	95-8166-18
E1	SR1 (-)	M16878/3BNL-9	PV8-14R	PV8-38R	5.00 [127.00]	95-8166-19

* N and L are the designations for the Mechron 120 VAC set.

Electrical Lead Fabrication Procedures:

1. Cut wire to length indicated, then strip 0.50 in. [13 mm] from each end of wire.
2. Crimp terminal "FROM" on one end of wire and terminal "TO" on other end.
3. Mark the appropriate wire number which will consist of the "FROM" termination, a double-headed arrow (↔), and the "TO" termination.
4. Install insulation sleeving, ST-301-3/16 over terminal, P14-6R and heat shrink to a tight fit.

Table 2. Electrical Lead Fabrication for Control Panel (MEP-501A).

TERMINATION		WIRE BULK NO.	"FROM" TERMINAL END	"TO" TERMINAL END	WIRE LENGTH in. [mm]	ELECTRICAL LEAD NO.
FROM	TO					
R3	M1-RED	M16878/3BJE-9	BACT12B301	BB-837-10	23.75 [603.25]	95-8056-1
R3	M1-BLK	M16878/3BJE-9	BACT12B301	BB-837-10	27.50 [698.50]	95-8056-2
R3	TB1-9	M16878/3BJE-9	BACT12B301	BACT12B301	5.00 [127.00]	95-8056-3
M1-RED	XF1	M16878/3BJE-9	BB-825-14	BACT12B301	9.00 [228.60]	95-8056-4
TB1-10	A1-F	M16878/3BJE-9	BACT12B301	RB2573	14.50 [368.30]	95-8056-5
TB1-9	A1-S	M16878/3BJE-9	BACT12B301	RB2573	13.88 [352.55]	95-8056-6
TB1-9	A1-A	M16878/3BJE-9	BACT12B301	RB2573	13.63 [346.20]	95-8056-7
TB1-12	A1-1	M16878/3BJE-9	BACT12B301	RB2573	13.50 [342.90]	95-8056-8
TB1-13	A1-2	M16878/3BJE-9	BACT12B301	RB2573	14.00 [355.60]	95-8056-9
TB1-11	A1-L	M16878/3BJE-9	BACT12B301	RB2573	13.63 [346.20]	95-8056-10
TB1-3	M3 (+)	M16878/3BJE-9	BACT12B301	RB2573	20.75 [527.05]	95-8056-11
TB1-3	CB1-P2 (LINE)	M16878/3BJE-9	BACT12B301	BB-837-10	8.00 [203.20]	95-8056-12
TB1-8	CB1-P2 (LOAD)	M16878/3BJE-9	BACT12B301	BB-837-10	7.00 [177.80]	95-8056-13
M2-RED	XF1	M16878/3BJE-9	640919-1	BB-837-10	13.00 [330.20]	95-8056-14
E1	M3 (-)	M16878/3BJE-9	RB2573	BB-825-14	29.25 [742.95]	95-8056-15
E1	TB1-1	M16878/3BJE-9	BB-825-14	BACT12B301	10.00 [254.00]	95-8056-16
M2-BLK	(-)	M16878/3BJE-9	BB-837-10	RB14-12	26.50 [673.10]	95-8056-17
TB1-2	(-)	M16878/3BJE-9	RB14-12	BACT12B301	5.00 [127.00]	95-8056-18
A1 GND	TB1-2	M16878/3BJE-9	RB2573	BACT12B301	9.13 [231.90]	95-8056-19
S2-B	SR1 (+)	M16878/3BNL-9	PV8-10R	PV8-38R	8.50 [215.90]	95-8056-20
R3	CB1-P1 (LINE)	M16878/3BRL-9	PV4-14R	PV4-14R	13.00 [330.20]	95-8056-21
CB1-P1 (LOAD)	(+)	M16878/3BRL-9	PV4-14R	PV4-12R	15.25 [387.35]	95-8056-22
(-)	SR1 (-)	M16878/3BRL-9	PV4-12R	PV4-38R	11.25 [285.75]	95-8056-23
E1	SR1 (-)	M16878/3BRL-9	PV4-14R	PV4-38R	5.63 [143.00]	95-8056-24

Electrical Lead Fabrication Procedures:

1. Cut wire to length indicated, then strip 0.5 in. [13 mm] from each end of wire.
2. Crimp terminal "FROM" on one end of wire and terminal "TO" on other end.
3. Mark the appropriate wire number which will consist of the "FROM" termination, a double-headed arrow (↔), and the "TO" termination.

END OF WORK PACKAGE

FIELD MAINTENANCE

**2 kW MEP-501A/531A MILITARY TACTICAL GENERATOR SETS
ILLUSTRATED LIST OF MANUFACTURED ITEMS INTRODUCTION**

ILLUSTRATED LIST OF MANUFACTURED ITEMS INTRODUCTION**Scope**

WP 0099 through WP 0114 includes complete instructions for making items authorized to be manufactured or fabricated at the field maintenance level.

How to Use the Index of Manufactured Items

A part number index in alphanumeric order is provided for cross-referencing the part number of the item to be manufactured to the information which covers fabrication criteria.

Explanation of the Illustrations of Manufactured Items

All instructions needed by maintenance personnel to manufacture the item are included on the illustrations. All bulk materials needed for manufacture of an item are listed by part number or specification number in a tabular list on the illustration.

INDEX OF MANUFACTURED ITEMS

P/N AND/OR DWG NO	PART DESCRIPTION	REFERENCE
95-8077	Potentiometer, VOLTAGE ADJ. (P/N: 95-8077)	WP 0099
95-8014	Potentiometer, VOLTAGE ADJ. (P/N: 95-8014)	WP 0100
95-8050	Flywheel Diode Assembly (P/N: 95-8050)	WP 0101
95-8017	Capacitor Assembly (P/N: 95-8017)	WP 0102
95-8019	LOP Solenoid Valve Assembly (P/N: 95-8019)	WP 0103
95-8084	Wiring Harness, Control Panel (P/N: 95-8084)	WP 0104
95-8023	Wiring Harness, Control Panel (P/N: 95-8023)	WP 0105
95-8075	Wiring Harness, Control Panel (P/N: 95-8075)	WP 0106
95-8022	Wiring Harness, Control Panel (P/N: 95-8022)	WP 0107
95-8029	Wiring Harness, Engine (P/N: 95-8029)	WP 0108
95-8082	LOP Shutdown Cable (P/N: 95-8082)	WP 0109
95-8141	Preheater Lead, Electrical (P/N: 95-8141)	WP 0110
95-8028	Wiring Harness, Alternator (P/N: 95-8028)	WP 0111

INDEX OF MANUFACTURED ITEMS - Continued

P/N AND/OR DWG NO	PART DESCRIPTION	REFERENCE
95-8025	Transient Suppressor (P/N: 95-8025)	WP 0112
114250-92101	Flywheel Locking Handle (P/N: 114250-92101)	WP 0113
114250-92130	Flywheel Extractor (P/N: 114250-92130)	WP 0114

END OF WORK PACKAGE

FIELD MAINTENANCE

2 kW MEP-501A/531A MILITARY TACTICAL GENERATOR SETS

POTENTIOMETER, VOLTAGE ADJ. (P/N: 95-8077)

INITIAL SETUP:

Not Applicable

P/N 95-8077

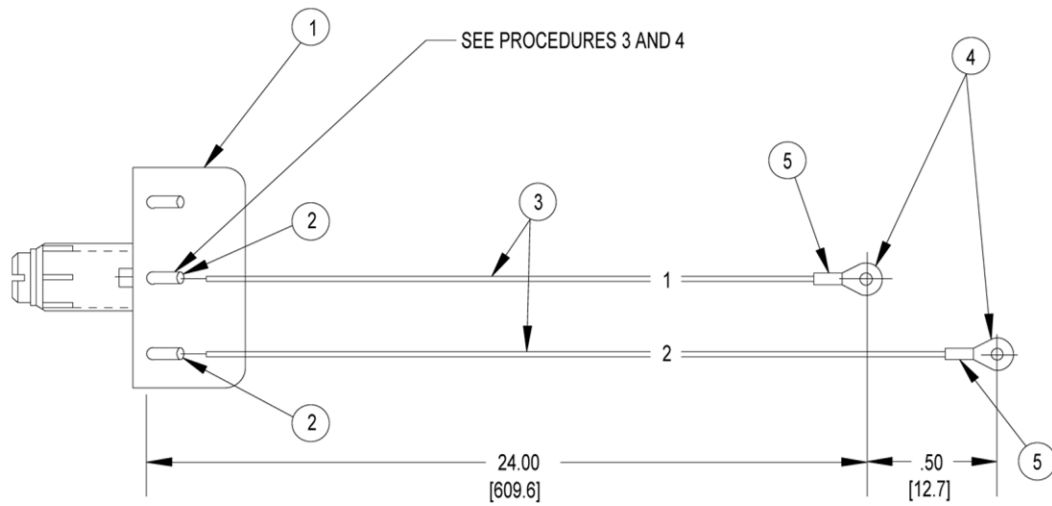

WIRE REF NO.	TERMINATION		WIRE BULK NO.
	FROM	TO	
1	R2	TB1-12	M16878/3BJE-9
2	R2	TB1-11	M16878/3BJE-9

Figure 1. Potentiometer, VOLTAGE ADJ. (P/N: 95-8077) (Sheet 1 of 2).

NOTES:

1. DIMENSIONS ARE SHOWN IN INCHES AND DIMENSIONS IN [] ARE IN MILLIMETERS.
2. REFER TO VOLTAGE ADJUST POTENTIOMETER RPSTL FOR MATERIALS REQUIRED.

PROCEDURES:

1. CUT EACH WIRE (3) TO LENGTH INDICATED THEN STRIP 0.50 [13] FROM ENDS OF EACH WIRE.
2. SOLDER WIRES (3) TO TERMINALS ON POTENTIOMETER (1).
3. INSTALL 0.25 TO 0.75 [6.4 TO 19.1] OF INSULATION SLEEVING (2) OVER SOLDERED TERMINALS ON POTENTIOMETER (1) AND HEAT SHRINK INSULATION TO A FIRM FIT.
4. SLIDE INSULATION SLEEVING (5) OVER WIRES (3). CRIMP TERMINAL LUG (4) ON END OF WIRES (3). INSTALL INSULATION SLEEVING (5) OVER TERMINAL LUGS (4) AND HEAT SHRINK TO A FIRM FIT.
5. MARK THE APPROPRIATE WIRE NUMBER WHICH WILL CONSIST OF THE "FROM" TERMINATION, A DOUBLE-HEADED ARROW ↔ AND THE "TO" TERMINATION.

Figure 1. Potentiometer, VOLTAGE ADJ. (P/N: 95-8077) (Sheet 2 of 2).

END OF TASK

END OF WORK PACKAGE

FIELD MAINTENANCE

2 kW MEP-501A/531A MILITARY TACTICAL GENERATOR SETS
 POTENTIOMETER, VOLTAGE ADJ. (P/N: 95-8014)

INITIAL SETUP:

Not Applicable

P/N 95-8014

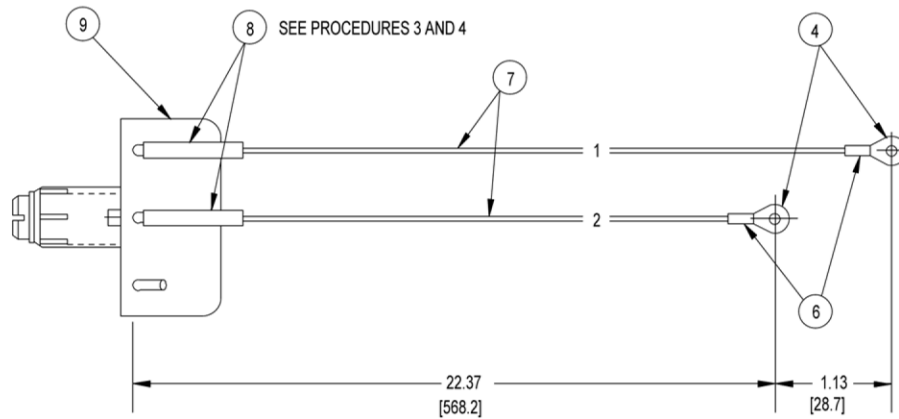

WIRE REF NO.	TERMINATION		WIRE BULK NO.
	FROM	TO	
1	R2	TB1-13	M16878/3BJE-9
2	R2	TB1-12	M16878/3BJE-9

Figure 1. Potentiometer, VOLTAGE ADJ. (P/N: 95-8014) (Sheet 1 of 2).

NOTES:

1. DIMENSIONS ARE SHOWN IN INCHES AND DIMENSIONS IN [] ARE IN MILLIMETERS.
2. REFER TO VOLTAGE ADJUST POTENTIOMETER RPSTL FOR MATERIALS REQUIRED.

PROCEDURES:

1. CUT EACH WIRE (7) TO LENGTH INDICATED THEN STRIP 0.50 [13] FROM ENDS OF EACH WIRE.
2. SOLDER WIRES (7) TO TERMINALS ON POTENTIOMETER (9).
3. INSTALL 0.25 TO 0.75 [6.4 TO 19.1] OF INSULATION SLEEVING (8) OVER SOLDERED TERMINALS ON POTENTIOMETER (9) AND HEAT SHRINK INSULATION TO A FIRM FIT.
4. SLIDE INSULATION SLEEVING (6) OVER WIRES (7). CRIMP TERMINAL LUGS (4) ON END OF WIRES (7). INSTALL INSULATION SLEEVING (6) OVER TERMINAL LUGS (4) AND HEAT SHRINK TO A FIRM FIT.
5. MARK THE APPROPRIATE WIRE NUMBER WHICH WILL CONSIST OF THE "FROM" TERMINATION, A DOUBLE-HEADED ARROW ↔ AND THE "TO" TERMINATION.

Figure 1. Potentiometer, VOLTAGE ADJ. (P/N: 95-8014) (Sheet 2 of 2).

END OF TASK

END OF WORK PACKAGE

FIELD MAINTENANCE

2 kW MEP-501A/531A MILITARY TACTICAL GENERATOR SETS

FLYWHEEL DIODE ASSEMBLY (P/N: 95-8050)

INITIAL SETUP:

Not Applicable

P/N 95-8050

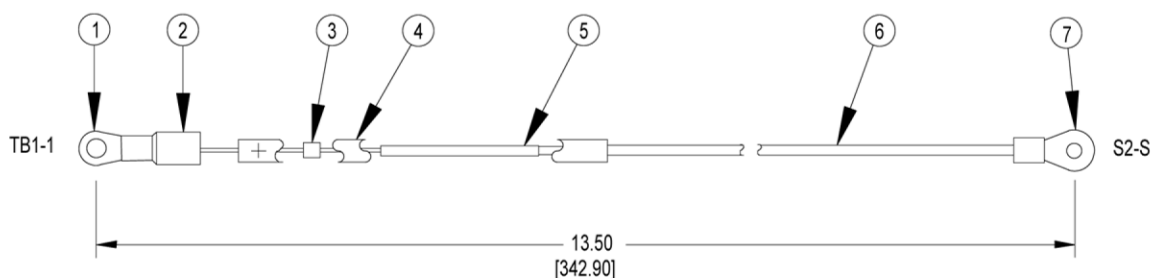

NOTES:

1. DIMENSIONS ARE SHOWN IN INCHES AND DIMENSIONS IN [] ARE IN MILLIMETERS.
2. REFER TO FLYWHEEL DIODE ASSEMBLY RPSTL FOR MATERIALS REQUIRED.

PROCEDURES:

1. CUT WIRE (6) TO LENGTH INDICATED THEN STRIP 0.50 [13] FROM ENDS OF WIRE.
2. INSTALL INSULATION SLEEVING (2) BY SLIDING OVER POSITIVE WIRE OF DIODE (3).
3. CRIMP TERMINAL LUG (1) TO POSITIVE WIRE OF DIODE (3).
4. INSTALL INSULATION SLEEVING (2) OVER TERMINAL LUG (1), AND HEAT SHRINK TO A FIRM FIT.
5. SLIDE SPLICE (5) OVER NEGATIVE WIRE OF DIODE (3) AND CRIMP.
6. SLIDE WIRE (6) INTO SPLICE (5) AND CRIMP.
7. SLIDE INSULATION MARKER (4) OVER WIRE (6), SPLICE (5) AND DIODE (3), THEN HEAT SHRINK TO A FIRM FIT.
8. SLIDE TERMINAL LUG (7) ONTO WIRE (6) AND CRIMP.
9. MARK THE APPROPRIATE WIRE NUMBER WHICH WILL CONSIST OF THE "FROM" TERMINATION, A DOUBLE-HEADED ARROW ↔ AND THE "TO" TERMINATION.

Figure 1. Flywheel Diode Assembly (P/N: 95-8050).

END OF TASK

END OF WORK PACKAGE

FIELD MAINTENANCE

2 kW MEP-501A/531A MILITARY TACTICAL GENERATOR SETS

CAPACITOR ASSEMBLY (P/N: 95-8017)

INITIAL SETUP:

Not Applicable

P/N 95-8017

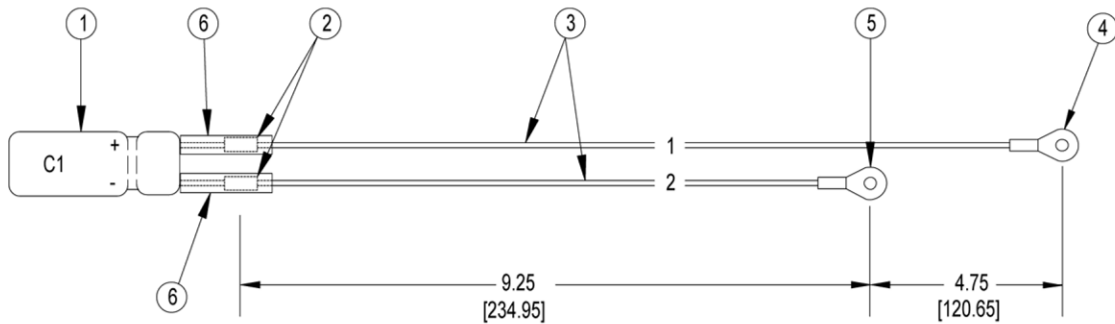

WIRE REF NO.	TERMINATION		WIRE BULK NO.
	FROM	TO	
1	C1 (+)	CB1-P1 (LINE)	M16878/3BJE-9
2	C1 (-)	-	M16878/3BJE-9

NOTES:

1. DIMENSIONS ARE SHOWN IN INCHES AND DIMENSIONS IN [] ARE IN MILLIMETERS.
2. REFER TO CAPACITOR ASSEMBLY (MEP-501A) RPSTL FOR MATERIALS REQUIRED.

PROCEDURES:

1. CUT EACH WIRE (3) TO LENGTH INDICATED, THEN STRIP 0.50 [13] FROM ENDS OF EACH WIRE.
2. ATTACH WIRES (3) TO CAPACITOR (1) LEADS WITH SPLICES (2). INSTALL INSULATION SLEEVING (6) OVER SPLICES (2) AND HEAT SHRINK TO A FIRM FIT.
3. CRIMP TERMINAL LUG (4) TO ONE END OF LONGER WIRE AND TERMINAL LUG (5) ON END OF OTHER WIRE.
4. MARK THE APPROPRIATE WIRE NUMBER WHICH WILL CONSIST OF THE "FROM" TERMINATION, A DOUBLE-HEADED ARROW ↔ AND THE "TO" TERMINATION.

Figure 1. Capacitor Assembly (P/N: 95-8017).

END OF TASK

END OF WORK PACKAGE

FIELD MAINTENANCE

2 kW MEP-501A/531A MILITARY TACTICAL GENERATOR SETS

LOP SOLENOID VALVE ASSEMBLY (P/N: 95-8019)

INITIAL SETUP:

Not Applicable

P/N 95-8019

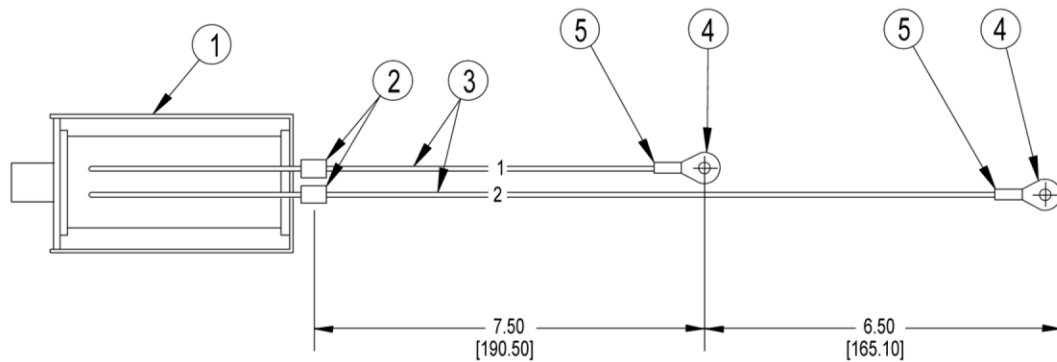

WIRE REF NO.	TERMINATION (MEP-531A)		TERMINATION (MEP-501A)		WIRE BULK NO.
	FROM	TO	FROM	TO	
1	L4 (Y)	TB1-4	L4 (YEL)	TB1-5	M16878/3BJE-9
2	L4 (R)	TB1-2	L4 (RED)	TB1-3	M16878/3BJE-9

NOTES:

1. DIMENSIONS ARE SHOWN IN INCHES AND DIMENSIONS IN [] ARE IN MILLIMETERS.
2. REFER TO LOP SHUTDOWN SOLENOID ASSEMBLY RPSTL FOR MATERIALS REQUIRED.

PROCEDURES:

1. CUT EACH WIRE (3) TO LENGTH INDICATED, THEN STRIP 0.50 [13] FROM ENDS OF EACH WIRE.
2. ATTACH WIRES (3) TO SOLENOID (1) LEADS WITH SPLICES (2).
3. SLIDE INSULATION SLEEVING (5) OVER WIRES (3).
4. CRIMP TERMINAL LUG (4) ON ONE END OF EACH WIRE. INSTALL INSULATION SLEEVING (5) OVER TERMINAL LUGS (4) AND HEAT SHRINK TO A FIRM FIT.
5. MARK THE APPROPRIATE WIRE NUMBER WHICH WILL CONSIST OF THE "FROM" TERMINATION, A DOUBLE-HEADED ARROW ↔ AND THE "TO" TERMINATION.

Figure 1. LOP Solenoid Valve Assembly (P/N: 95-8019).

END OF TASK

END OF WORK PACKAGE

FIELD MAINTENANCE

2 kW MEP-501A/531A MILITARY TACTICAL GENERATOR SETS

WIRING HARNESS, CONTROL PANEL (P/N: 95-8084)

INITIAL SETUP:

Not Applicable

P/N 95-8084

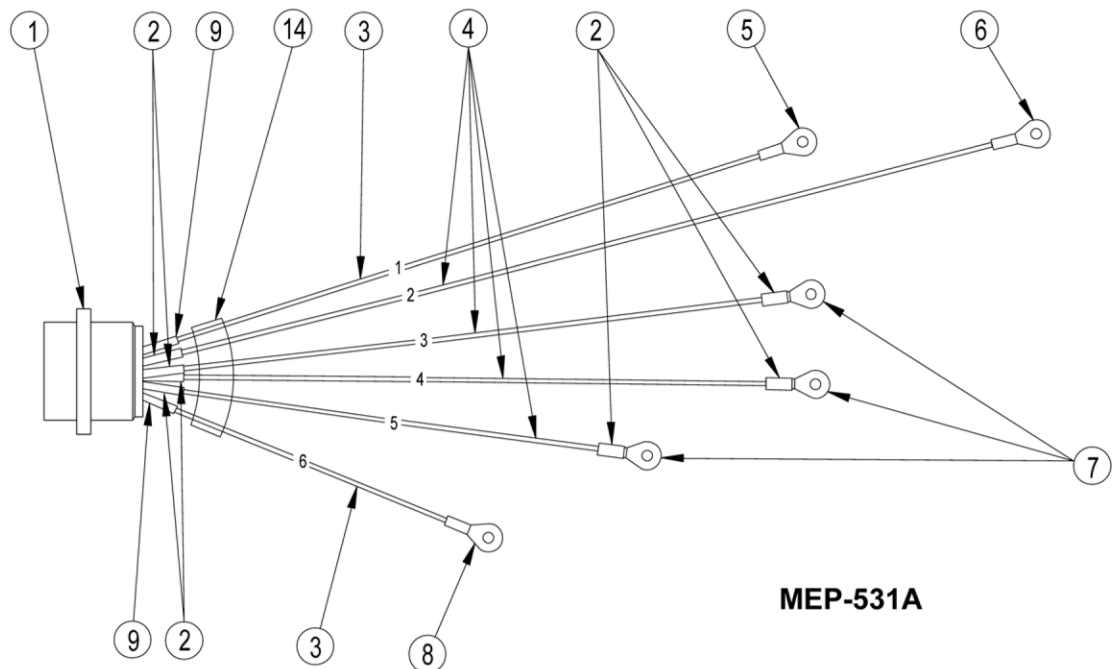

WIRE REF NO.	TERMINATION		WIRE BULK NO.	WIRE LENGTH
	FROM	TO		
1	J2-A	S2-H	M16878/3BNL-9	12.25 [311.15]
2	J2-C	S2-S	M16878/3BJE-9	14.87 [377.7]
3	J2-B	TB1-4	M16878/3BJE-9	8.75 [222.25]
4	J2-E	TB1-6	M16878/3BJE-9	8.25 [209.5]
5	J2-F	TB1-7	M16878/3BJE-9	7.50 [190.5]
6	J2-D	SR1 (+)	M16878/3BNL-9	8.25 [209.5]

Figure 1. Wiring Harness, Control Panel (P/N: 95-8084) (Sheet 1 of 2).

NOTES:

1. DIMENSIONS ARE SHOWN IN INCHES AND DIMENSIONS IN [] ARE IN MILLIMETERS.
2. REFER TO CONTROL PANEL ENGINE WIRING HARNESS (MEP-531A/501A) RPSTL FOR MATERIALS REQUIRED
3. CONNECTOR SHALL BE MARKED "J2" ON INSULATION SLEEVING (14) WITH 0.18 [5] MINIMUM HIGH CHARACTERS IAW MIL-STD-130 USING RUBBER STAMP OR STENCIL.

PROCEDURES:

1. CUT EACH WIRE (3) AND (4) TO LENGTH INDICATED, THEN STRIP 0.50 [13] FROM ENDS OF EACH WIRE.
2. INSERT WIRES (3) AND (4) INTO EACH PIN FROM CONNECTOR (1) AND CRIMP USING CRIMPING TOOL.
3. SLIDE .75 TO 1.25 [19.1 TO 31.8] OF INSULATION SLEEVING (9) OVER WIRE (3) AND INSULATION SLEEVING (2) OVER WIRE (4).
4. USING A PIN INSERTION TOOL, INSERT PINS FROM CONNECTOR (1) INTO CONNECTOR (1) UNTIL PINS LOCK INTO PLACE, FOLLOWING TERMINATION INDICATORS IN WIRE LIST REFERENCE TABLE.
5. SLIDE INSULATION SLEEVING (2) OVER EACH OF THE WIRE REFERENCE NUMBERS 2, 3, 4 AND 5, AND INSULATION SLEEVING (9) OVER EACH OF THE WIRE REFERENCE NUMBERS 1 AND 6, TO CONNECTOR (1) AND HEAT SHRINK TO A FIRM FIT.
6. SLIDE INSULATION SLEEVING (14) OVER WIRE BUNDLE TO CONNECTOR (1), AND HEAT SHRINK TO A FIRM FIT.
7. SLIDE INSULATION SLEEVING (2) OVER EACH OF THE WIRE REFERENCE NUMBERS 3, 4 AND 5.
8. SLIDE TERMINAL LUG (7) ONTO WIRE REFERENCE NUMBERS 3, 4 AND 5 AND CRIMP. SLIDE INSULATION SLEEVING (2) OVER TERMINAL LUGS (7) AND HEAT SHRINK TO A FIRM FIT.
9. SLIDE TERMINAL LUGS (5), (6) AND (8) ONTO WIRE REFERENCE NUMBERS 1, 2 AND 6 AND CRIMP.
10. MARK THE APPROPRIATE WIRE NUMBER WHICH WILL CONSIST OF THE "FROM" TERMINATION, A DOUBLE-HEADED ARROW ↔ AND THE "TO" TERMINATION.

Figure 1. Wiring Harness, Control Panel (P/N: 95-8084) (Sheet 2 of 2).

END OF TASK

END OF WORK PACKAGE

FIELD MAINTENANCE

2 kW MEP-501A/531A MILITARY TACTICAL GENERATOR SETS

WIRING HARNESS, CONTROL PANEL (P/N: 95-8023)

INITIAL SETUP:

Not Applicable

P/N 95-8023

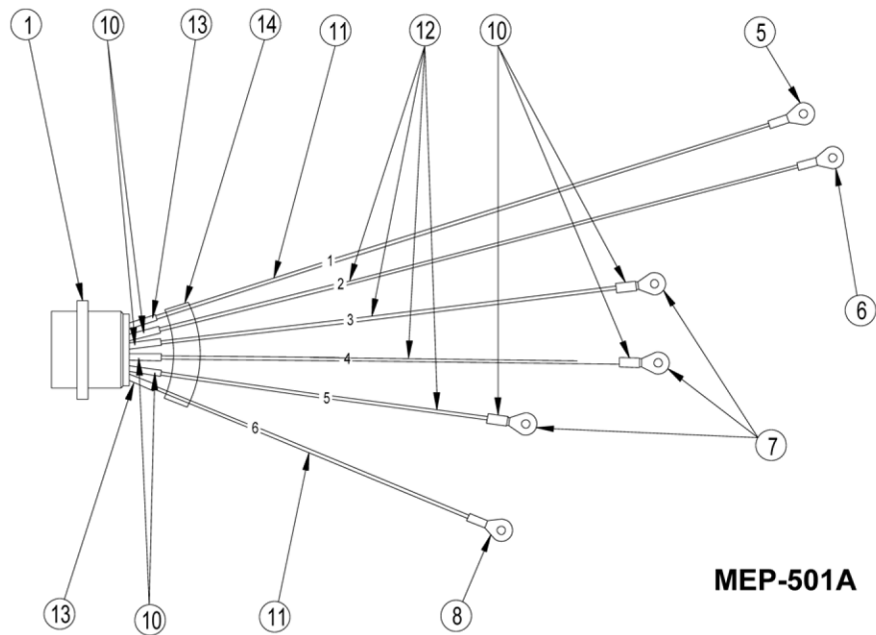

WIRE REF NO.	TERMINATION		WIRE BULK NO.	WIRE LENGTH
	FROM	TO		
1	J2-A	S2-H	M16878/3BNL-9	12.25 [311.15]
2	J2-C	S2-S	M16878/3BJE-9	14.87 [377.7]
3	J2-B	TB1-4	M16878/3BJE-9	8.75 [222.25]
4	J2-E	TB1-6	M16878/3BJE-9	8.25 [209.5]
5	J2-F	TB1-7	M16878/3BJE-9	7.50 [190.5]
6	J2-D	SR1 (+)	M16878/3BNL-9	8.25 [209.5]

Figure 1. Wiring Harness, Control Panel (P/N: 95-8023) (Sheet 1 of 2).

NOTES:

1. DIMENSIONS ARE SHOWN IN INCHES AND DIMENSIONS IN [] ARE IN MILLIMETERS.
2. REFER TO THE CONTROL PANEL WIRING HARNESSSES (MEP-531A/501A) RPSTL FOR MATERIALS REQUIRED.
3. CONNECTOR SHALL BE MARKED "J2" ON INSULATION SLEEVING (14) WITH 0.18 [5] MINIMUM HIGH CHARACTERS IAW MIL-STD-130 USING RUBBER STAMP OR STENCIL.

PROCEDURES:

1. CUT EACH WIRE (11) AND (12) TO LENGTH INDICATED, THEN STRIP 0.50 [13] FROM ENDS OF EACH WIRE.
2. INSERT WIRES (11) AND (12) INTO EACH PIN FROM CONNECTOR (1) AND CRIMP USING CRIMPING TOOL.
3. SLIDE .75 TO 1.25 [19.1 TO 31.8] OF INSULATION SLEEVING (10) OVER WIRE (12) AND INSULATION SLEEVING (13) OVER WIRE (11).
4. USING A PIN INSERTION TOOL, INSERT PINS FROM CONNECTOR (1) INTO CONNECTOR (1) UNTIL PINS LOCK INTO PLACE, FOLLOWING TERMINATION INDICATORS IN WIRE LIST REFERENCE TABLE.
5. SLIDE INSULATION SLEEVING (10) AND (13) TO CONNECTOR (1), AND HEAT SHRINK TO A FIRM FIT.
6. SLIDE INSULATION SLEEVING (14) OVER WIRE BUNDLE TO CONNECTOR (1), AND HEAT SHRINK TO A FIRM FIT.
7. SLIDE INSULATION SLEEVING (10) OVER EACH OF THE WIRE REFERENCE NUMBERS 3, 4 AND 5.
8. SLIDE TERMINAL LUG (7) ONTO WIRE REFERENCE NUMBERS 3, 4 AND 5 AND CRIMP. SLIDE INSULATION SLEEVING (10) OVER TERMINAL LUGS (7) AND HEAT SHRINK TO A FIRM FIT.
9. SLIDE TERMINAL LUGS (5), (6) AND (8) ONTO WIRE REFERENCE NUMBERS 1, 2 AND 6 AND CRIMP.
10. MARK THE APPROPRIATE WIRE NUMBER WHICH WILL CONSIST OF THE "FROM" TERMINATION, A DOUBLE-HEADED ARROW ↔ AND THE "TO" TERMINATION.

Figure 1. Wiring Harness, Control Panel (P/N: 95-8023) (Sheet 2 of 2).

END OF TASK

END OF WORK PACKAGE

FIELD MAINTENANCE

2 kW MEP-501A/531A MILITARY TACTICAL GENERATOR SETS

WIRING HARNESS, CONTROL PANEL (P/N: 95-8075)

INITIAL SETUP:

Not Applicable

P/N 95-8075

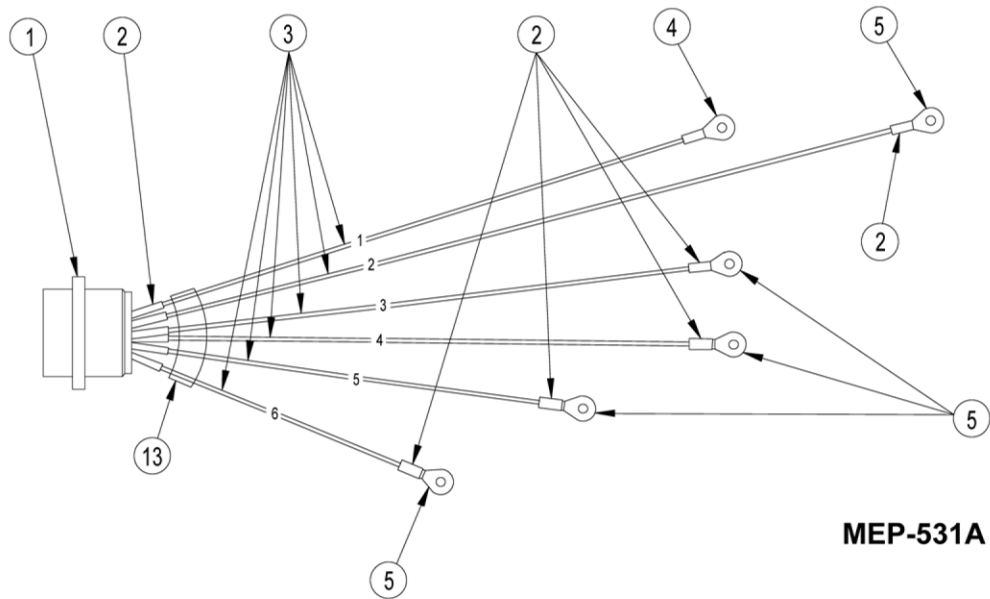

MEP-531A

WIRE REF NO.	TERMINATION		WIRE BULK NO.	WIRE LENGTH
	FROM	TO		
1	J1-B	FL1-N*	M16878/3BKE-9	12.00 [304.8]
2	J1-A	TB1-13	M16878/3BKE-9	10.50 [266.7]
3	J1-C	TB1-14	M16878/3BKE-9	11.50 [292.1]
4	J1-D	TB1-15	M16878/3BKE-9	12.00 [304.8]
5	J1-E	TB1-8	M16878/3BKE-9	9.25 [234.9]
6	J1-F	TB1-9	M16878/3BKE-9	10.00 [254.0]

* N for Mechtron 120 VAC set.

Figure 1. Wiring Harness, Control Panel (P/N: 95-8075) (Sheet 1 of 2).

NOTES:

1. DIMENSIONS ARE SHOWN IN INCHES AND DIMENSIONS IN [] ARE IN MILLIMETERS.
2. REFER TO THE CONTROL PANEL ALTERNATOR WIRING HARNESS (MEP-531A/501A) RPSTL FOR MATERIALS REQUIRED.
3. CONNECTOR SHALL BE MARKED "J2" ON INSULATION SLEEVING WITH 0.18 [5] MINIMUM HIGH CHARACTERS IAW MIL-STD-130 USING RUBBER STAMP OR STENCIL.

PROCEDURES:

1. CUT EACH WIRE (3) TO LENGTH INDICATED, THEN STRIP 0.50 [13] FROM ENDS OF EACH WIRE.
2. INSERT WIRES (3) INTO EACH PIN FROM CONNECTOR (1) AND CRIMP USING CRIMPING TOOL.
3. SLIDE 0.75 TO 1.25 [19.1 TO 31.8] OF INSULATION SLEEVING (2) OVER WIRES (3).
4. USING A PIN INSERTION TOOL, INSERT PINS FROM CONNECTOR (1) INTO CONNECTOR (1) UNTIL PINS LOCK INTO PLACE, FOLLOWING TERMINATION INDICATORS IN WIRE LIST REFERENCE TABLE.
5. SLIDE INSULATION SLEEVING (2) TO CONNECTOR (1), AND HEAT SHRINK TO A FIRM FIT.
6. SLIDE INSULATION SLEEVING (13) OVER WIRE BUNDLE TO CONNECTOR (1), AND HEAT SHRINK TO A FIRM FIT.
7. SLIDE INSULATION SLEEVING (2) OVER EACH OF THE WIRE REFERENCE NUMBERS 2, 3, 4, 5 AND 6.
8. SLIDE TERMINAL LUG (5) ONTO WIRE REFERENCE NUMBERS 2, 3, 4, 5 AND 6 AND CRIMP. SLIDE INSULATION SLEEVING (2) OVER TERMINAL LUGS (5) AND HEAT SHRINK TO A FIRM FIT.
9. SLIDE TERMINAL LUG (4) ONTO WIRE REFERENCE NUMBER 1 AND CRIMP.
10. MARK THE APPROPRIATE WIRE NUMBER WHICH WILL CONSIST OF THE "FROM" TERMINATION, A DOUBLE-HEADED ARROW ↔ AND THE "TO" TERMINATION.

Figure 1. Wiring Harness, Control Panel (P/N: 95-8075) (Sheet 2 of 2).

END OF TASK

END OF WORK PACKAGE

FIELD MAINTENANCE

2 kW MEP-501A/531A MILITARY TACTICAL GENERATOR SETS

WIRING HARNESS, CONTROL PANEL (P/N: 95-8022)

INITIAL SETUP:

Not Applicable

P/N 95-8022

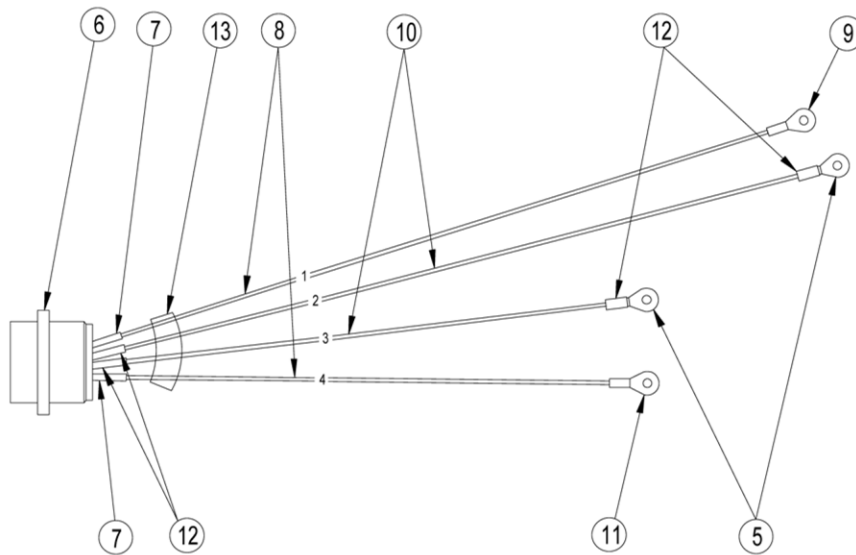

MEP-501A

WIRE REF NO.	TERMINATION		WIRE BULK NO.	WIRE LENGTH
	FROM	TO		
1	J1-A	R3	M16878/3BRL-9	4.75 [120.6]
2	J1-B	TB1-10	M16878/3BKE-9	10.25 [260.35]
3	J1-D	TB1-11	M16878/3BKE-9	10.50 [266.7]
4	J1-C	(-)	M16878/3BRL-9	4.75 [120.6]

Figure 1. Wiring Harness, Control Panel (P/N: 95-8022) (Sheet 1 of 2).

NOTES:

1. DIMENSIONS ARE SHOWN IN INCHES AND DIMENSIONS IN [] ARE IN MILLIMETERS.
2. REFER TO THE CONTROL PANEL ALTERNATOR WIRING HARNESS (MEP-531A/501A) RPSTL FOR MATERIALS REQUIRED.
3. CONNECTOR SHALL BE MARKED "J1" ON INSULATION SLEEVING (13) WITH 0.18 [5] MINIMUM HIGH CHARACTERS IAW MIL-STD-130 USING RUBBER STAMP OR STENCIL.

PROCEDURES:

1. CUT EACH WIRE (8) AND (10) TO LENGTH INDICATED, THEN STRIP 0.50 [13] FROM ENDS OF EACH WIRE.
2. INSERT WIRES (8) AND (10) INTO EACH PIN FROM CONNECTOR (1) AND CRIMP USING CRIMPING TOOL.
3. SLIDE 0.75 TO 1.25 [19.1 TO 31.8] OF INSULATION SLEEVING (7) OVER WIRE (8) AND INSULATION SLEEVING (12) OVER WIRE (10).
4. USING A PIN INSERTION TOOL, INSERT PINS FROM CONNECTOR (1) INTO CONNECTOR (1) UNTIL PINS LOCK INTO PLACE, FOLLOWING TERMINATION INDICATORS IN WIRE LIST REFERENCE TABLE.
5. SLIDE INSULATION SLEEVING (7) AND (12) TO CONNECTOR (1), AND HEAT SHRINK TO A FIRM FIT.
6. SLIDE INSULATION SLEEVING (13) OVER WIRE BUNDLE TO CONNECTOR (1), AND HEAT SHRINK TO A FIRM FIT.
7. SLIDE INSULATION (12) OVER EACH WIRE REFERENCE NUMBERS 2 AND 3.
8. SLIDE TERMINAL LUG (5) OVER WIRE REFERENCE NUMBERS 2 AND 3 AND CRIMP. SLIDE INSULATION SLEEVING (12) OVER TERMINAL LUGS (5) AND HEAT SHRINK TO A FIRM FIT.
9. SLIDE TERMINAL LUGS (9) AND (11) OVER WIRE REFERENCE NUMBERS 1 AND 4 AND CRIMP.
10. MARK THE APPROPRIATE WIRE NUMBER WHICH WILL CONSIST OF THE "FROM" TERMINATION, A DOUBLE-HEADED ARROW ↔ AND THE "TO" TERMINATION.

Figure 1. Wiring Harness, Control Panel (P/N: 95-8022) (Sheet 2 of 2).

END OF TASK

END OF WORK PACKAGE

FIELD MAINTENANCE

2 kW MEP-501A/531A MILITARY TACTICAL GENERATOR SETS

WIRING HARNESS, ENGINE (P/N: 95-8029)

INITIAL SETUP:

Not Applicable

P/N 95-8029

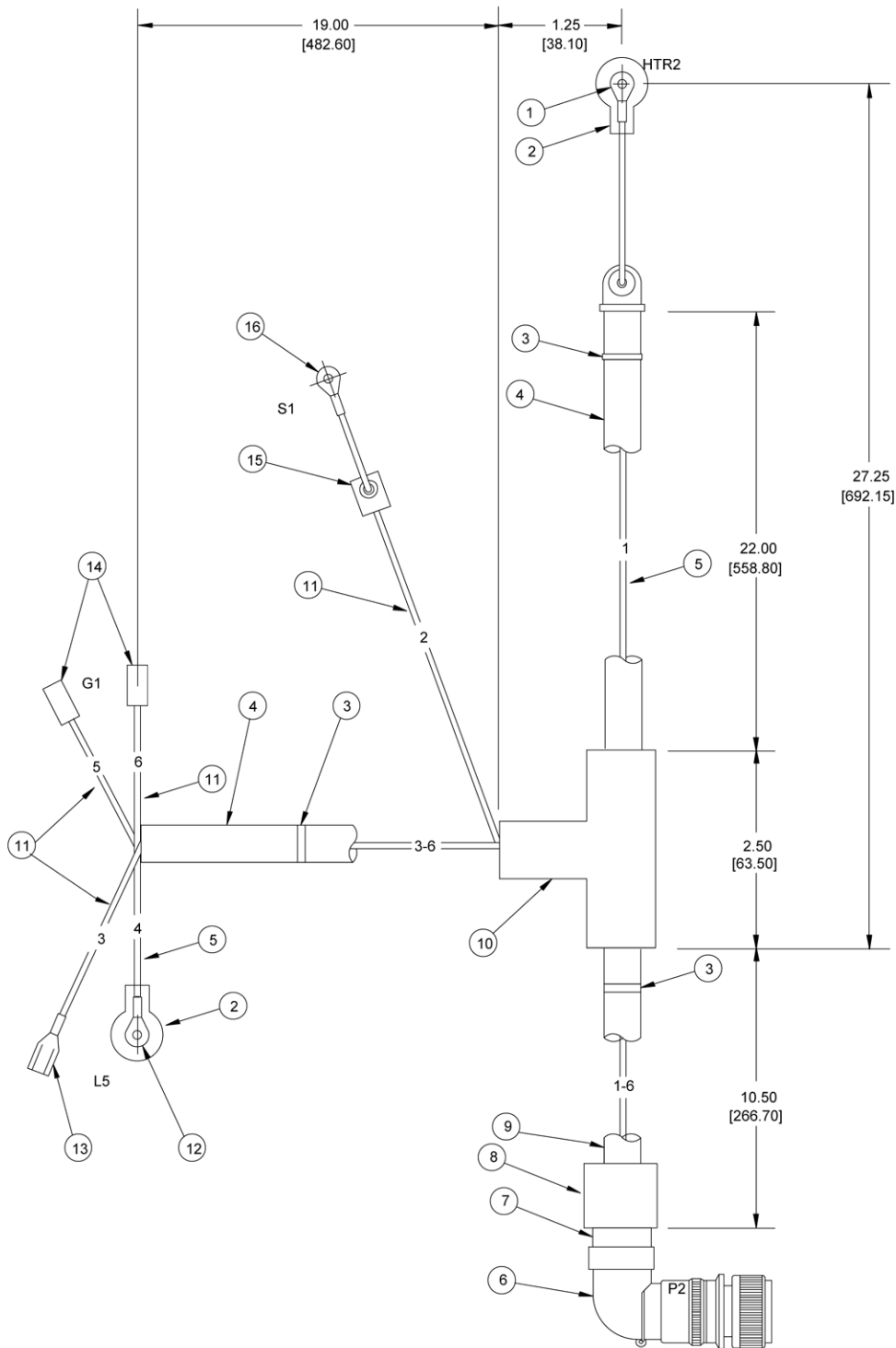

Figure 1. Wiring Harness, Engine (P/N: 95-8029) (Sheet 1 of 3).

WIRE REF NO.	TERMINATION		WIRE BULK NO.	WIRE LENGTH
	FROM	TO		
1	P2-A	HTR2	M16878/3BNL-9	37.75 [958.85]
2	P2-B	S1	M16878/3BJE-9	19.0 [482.6]
3	P2-C	L5-C	M16878/3BJE-9	36.0 [914.4]
4	P2-D	L5-S	M16878/3BNL-9	34.5 [876.3]
5	P2-E	G1	M16878/3BJE-9	32.5 [825.5]
6	P2-F	G1	M16878/3BJE-9	32.5 [825.5]

Figure 1. Wiring Harness, Engine (P/N: 95-8029) (Sheet 2 of 3).

NOTES:

1. DIMENSIONS ARE SHOWN IN INCHES AND DIMENSIONS IN [] ARE IN MILLIMETERS.
2. REFER TO THE DIESEL ENGINE MODIFIED RPSTL FOR MATERIALS REQUIRED.
3. CONNECTOR SHALL BE MARKED "P2" ON INSULATION SLEEVING WITH 0.18 [5] MINIMUM HIGH CHARACTERS IAW MIL-STD-130, USING RUBBER STAMP OR STENCIL.

PROCEDURES:

1. CUT EACH WIRE TO LENGTH INDICATED, THEN STRIP 0.50 [13] FROM ENDS OF EACH WIRE.
2. INSERT WIRES REF. NO. 1-6 INTO PINS FROM CONNECTOR (6) AND CRIMP USING CRIMPING TOOL.
3. SLIDE TUBING (9) AND 1.75 TO 2.25 [44.4 TO 57.2] OF INSULATION SLEEVING (8) OVER WIRES REF. NO. 1-6).
4. INSERT PINS FROM CONNECTOR (6) THROUGH CLAMP (7) AND USING A PIN INSERTION TOOL, INSERT PINS FROM CONNECTOR (6) INTO CONNECTOR (6) UNTIL PINS LOCK INTO PLACE, FOLLOWING TERMINATION INDICATORS IN WIRE LIST REFERENCE TABLE.
5. CLAMP WIRES REF. NO. 1-6 TO CONNECTOR (6).
6. SLIDE TUBING (9) UP TO CLAMP (7), SLIDE INSULATION SLEEVING (8) OVER TUBING (9) AND CLAMP (7), AND HEAT SHRINK TO A FIRM FIT.
7. CUT TUBING (4) INTO A 19 INCH LENGTH AND A 22 INCH LENGTH. SLIDE 22 INCH TUBING (4) OVER WIRE REF. NO. 1. SLIDE 19 INCH TUBING (4) OVER WIRES REF. NO. 3, 4, 5 AND 6.
8. INSERT TUBINGS (4) AND (9) INTO TEE (10) AND CLOSE TEE CLAMPING TUBES.
9. SLIDE NIPPLE (2) OVER WIRE REF. NO. 1. SLIDE TERMINAL LUG (1) OVER WIRE REF. NO. 1 AND CRIMP.
10. SLIDE BOOT (15) OVER WIRE REF. NO. 2. SLIDE TERMINAL LUG (16) OVER WIRE REF. NO. 2 AND CRIMP.
11. SLIDE QUICK DISCONNECT TERMINALS (14) OVER WIRES REF. NO. 5 AND 6 AND CRIMP. SLIDE QUICK DISCONNECT TERMINAL (13) OVER WIRE REF. NO. 3 AND CRIMP.
12. SLIDE NIPPLE (2) OVER WIRE REF. NO. 4. SLIDE TERMINAL LUG (12) OVER WIRE REF. NO. 4 AND CRIMP.
13. POSITION STRAPS (3) AT 3-INCH INTERVALS AND AT ALL BREAKOUTS.
14. MARK THE APPROPRIATE WIRE NUMBER WHICH WILL CONSIST OF THE "FROM" TERMINATION, A DOUBLE-HEADED ARROW ↔ AND THE "TO" TERMINATION.

Figure 1. Wiring Harness, Engine (P/N: 95-8029) (Sheet 3 of 3).

END OF TASK

END OF WORK PACKAGE

FIELD MAINTENANCE

2 kW MEP-501A/531A MILITARY TACTICAL GENERATOR SETS

LOP SHUTDOWN CABLE (P/N: 95-8082)

INITIAL SETUP:

Not Applicable

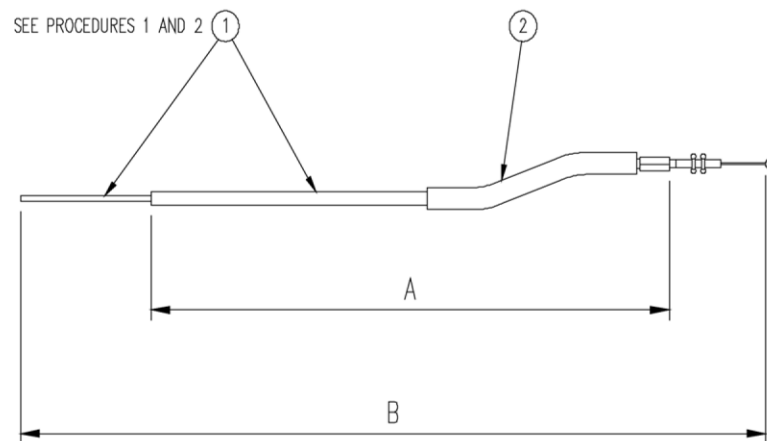
P/N 95-8082**NOTES:**

1. DIMENSIONS ARE SHOWN IN INCHES AND DIMENSIONS IN [] ARE IN MILLIMETERS.
2. REFER TO LOP ENGINE SHUTDOWN CABLE ASSEMBLY (MEP-531A/501A) RPSTL FOR MATERIALS REQUIRED.

PROCEDURES:

1. CUT OVERALL LENGTH OF OUTER CABLE (PART OF 1), 13.70 [348.0] LONG (DIMENSION A).
2. CUT OVERALL LENGTH OF INNER CIRCLE CABLE (PART OF 1), 16.54 [420.1] (DIMENSION B).

Figure 1. LOP Shutdown Cable (P/N: 95-8082).

END OF TASK

END OF WORK PACKAGE

FIELD MAINTENANCE

2 kW MEP-501A/531A MILITARY TACTICAL GENERATOR SETS

PREHEATER LEAD, ELECTRICAL (P/N: 95-8141)

INITIAL SETUP:

Not Applicable

P/N 95-8141

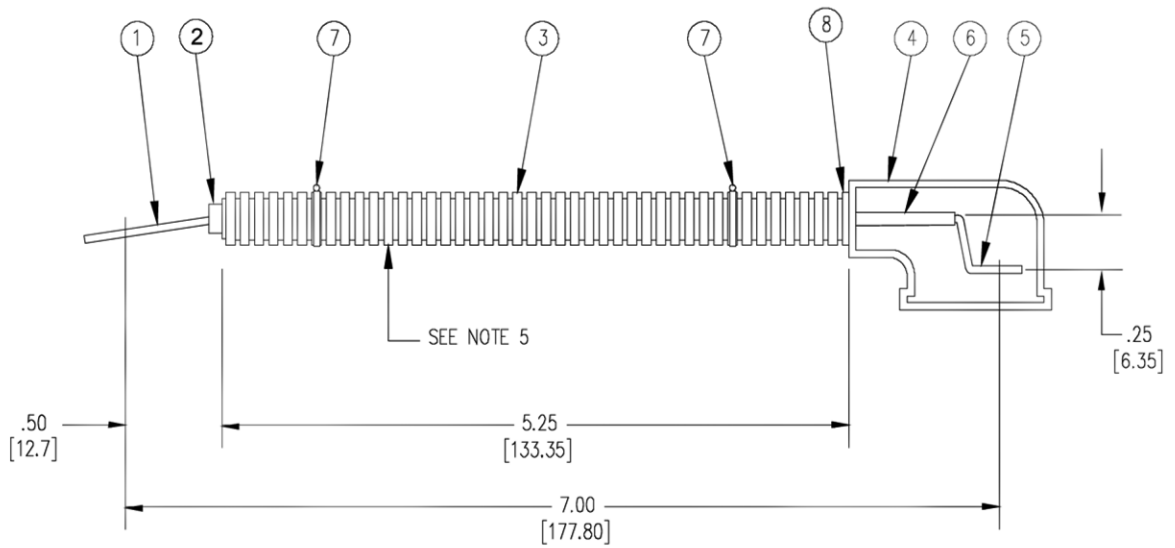

TERMINATION		WIRE BULK NO.
FROM	TO	
ENG HEAD BOLT	HTR1	M16878/3BNL-9

Figure 1. Preheater Lead, Electrical (P/N: 95-8141) (Sheet 1 of 2).

NOTES:

1. DIMENSIONS ARE SHOWN IN INCHES AND DIMENSIONS IN [] ARE IN MILLIMETERS.
2. REFER TO THE PREHEATER LEAD ASSEMBLY (MEP-531A/501A) RPSTL FOR MATERIALS REQUIRED.

PROCEDURES:

1. CUT WIRE (6) TO 8.0 [203.2], THEN STRIP 0.5 [13] FROM ENDS OF WIRE.
2. SLIDE INSULATION SLEEVING (2) OVER WIRE (6).
3. CRIMP TERMINAL LUG (1) TO ONE END OF WIRE (6) AND TERMINAL LUG (5) TO OTHER END OF WIRE (6).
4. SLIDE INSULATION SLEEVING (2) OVER TERMINAL LUG (1) AND HEAT SHRINK TO A TIGHT FIT.
5. SLIDE TUBE (3) OVER WIRE ASSEMBLY (1, 2, 5 AND 6). SLIDE NIPPLE (4) OVER TERMINAL LUG (5) AND TUBE (3).
6. INSTALL INSULATION SLEEVING (8) OVER TUBE (3) AND NIPPLE (4) AND HEAT SHRINK TO A FIRM FIT.
7. TUBE (3) SHALL BE BONDED TOGETHER WITH CABLE TIES (7) AT 3 INCH INTERVALS.
8. MARK THE APPROPRIATE WIRE NUMBER WHICH WILL CONSIST OF THE "FROM" TERMINATION, A DOUBLE-HEADED ARROW ↔ AND THE "TO" TERMINATION.

Figure 1. Preheater Lead, Electrical (P/N: 95-8141) (Sheet 2 of 2).

END OF TASK

END OF WORK PACKAGE

FIELD MAINTENANCE

2 kW MEP-501A/531A MILITARY TACTICAL GENERATOR SETS

WIRING HARNESS, ALTERNATOR (P/N: 95-8028)

INITIAL SETUP:

Not Applicable

P/N 95-8028

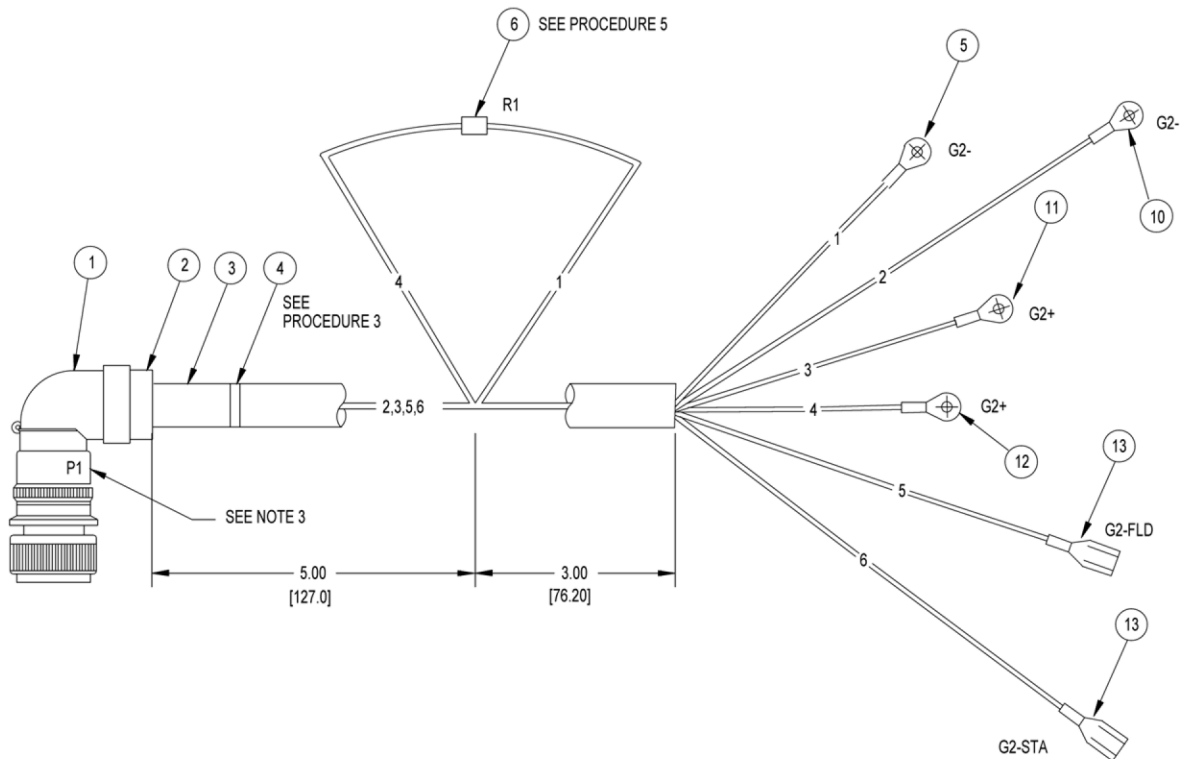

WIRE REF NO.	TERMINATION		WIRE BULK NO.	WIRE LENGTH
	FROM	TO		
1	R1	G2-	M16878/3BKE-9	12.75 [323.85]
2	P1-C	G2-	M16878/3BRL-9	13.75 [349.25]
3	P1-A	G2+	M16878/3BRL-9	12.0 [304.8]
4	R1	G2+	M16878/3BKE-9	12.25 [311.15]
5	P1-B	G2-FLD	M16878/3BKE-9	15.25 [387.25]
6	P1-D	G2-STA	M16878/3BKE-9	15.25 [387.25]

Figure 1. Wiring Harness, Alternator (P/N: 95-8028) (Sheet 1 of 2).

NOTES:

1. DIMENSIONS ARE SHOWN IN INCHES AND DIMENSIONS IN [] ARE IN MILLIMETERS.
2. REFER TO THE ALTERNATOR WIRING HARNESS (MEP-501A) RPSTL FOR MATERIALS REQUIRED.
3. CONNECTOR (1) SHALL BE MARKED "P1" ON INSULATION SLEEVING (14) WITH 0.18 [5] MINIMUM HIGH CHARACTERS IAW MIL-STD-130, USING RUBBER STAMP OR STENCIL.

PROCEDURES:

1. CUT EACH WIRE TO LENGTH INDICATED, THEN STRIP 0.5 [13] FROM ENDS OF EACH WIRE.
2. CRIMP TERMINAL LUG (9) TO WIRE REF. NO. 1. CRIMP TERMINAL LUG (10) TO WIRE REF. NO. 2. CRIMP TERMINAL LUG (11) TO WIRE REF. NO. 3. CRIMP TERMINAL LUG (12) TO WIRE REF. NO. 4. CRIMP QUICK DISCONNECTS (13) TO WIRES REF. NO. 5 AND 6.
3. POSITION STRAPS (4) AT 3 INCH INTERVALS AND AT ALL BREAKOUTS.
4. MARK THE APPROPRIATE WIRE NUMBER WHICH WILL CONSIST OF THE "FROM" TERMINATION, A DOUBLE-HEADED ARROW ↔ AND THE "TO" TERMINATION.
5. SOLDER LEADS, WIRES REF. NO. 1 AND 4 TO RESISTOR (6) AND COVER SOLDER CONNECTIONS WITH 0.75 TO 1.25 [19.1 TO 31.8] OF INSULATION SLEEVING (7) AND HEAT SHRINK TO A FIRM FIT.
6. INSERT TUBING (3) INTO BUSHING (PART OF 2), AND COVER WITH 1.75 TO 2.25 [45.1 TO 57.8] OF INSULATION SLEEVING (14) AND HEAT SHRINK TO A FIRM FIT.

Figure 1. Wiring Harness, Alternator (P/N: 95-8028) (Sheet 2 of 2).

END OF TASK

END OF WORK PACKAGE

FIELD MAINTENANCE

2 kW MEP-501A/531A MILITARY TACTICAL GENERATOR SETS
TRANSIENT SUPPRESSOR (P/N: 95-8025)

INITIAL SETUP:

Not Applicable

P/N 95-8025

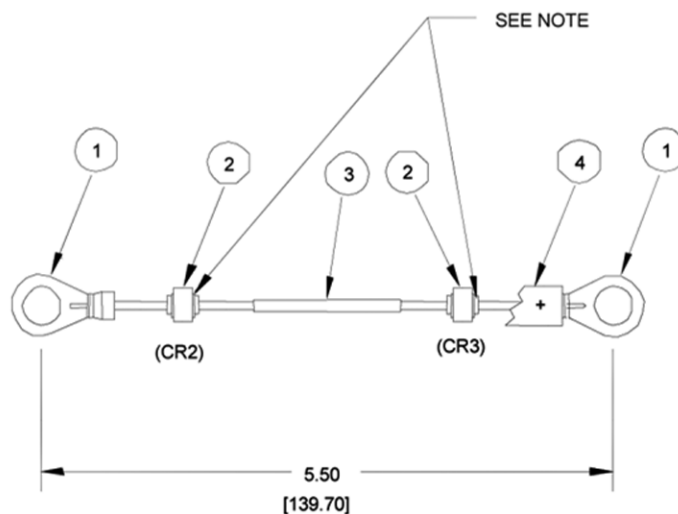

NOTES:

1. DIMENSIONS ARE SHOWN IN INCHES AND DIMENSIONS IN [] ARE IN MILLIMETERS.
2. REFER TO THE TRANSIENT SUPPRESSOR ASSEMBLY (MEP-501A) RPSTL FOR MATERIALS REQUIRED.

PROCEDURES:

NOTE

INSTALL DIODES (2) TO ORIENT CATHODE INDICATOR BAND AS SHOWN.

1. CRIMP TERMINAL LUGS (1) TO EACH DIODE (2).
2. SLIDE SPLICE (3) OVER WIRE OF EACH DIODE (2) AND CRIMP.
3. INSTALL MARKER (4) OVER DIODES (2) AND SPLICE (3) AND HEAT SHRINK TO A FIRM FIT.

Figure 1. Transient Suppressor (P/N: 95-8025).

END OF TASK

END OF WORK PACKAGE

FIELD MAINTENANCE

2 kW MEP-501A/531A MILITARY TACTICAL GENERATOR SETS
 FLYWHEEL LOCKING HANDLE (P/N: 114250-92101)

INITIAL SETUP:

Not Applicable

P/N 114250-92101

Flywheel Locking Tool

Material: steel

Scale: free

Unit: in. (mm)

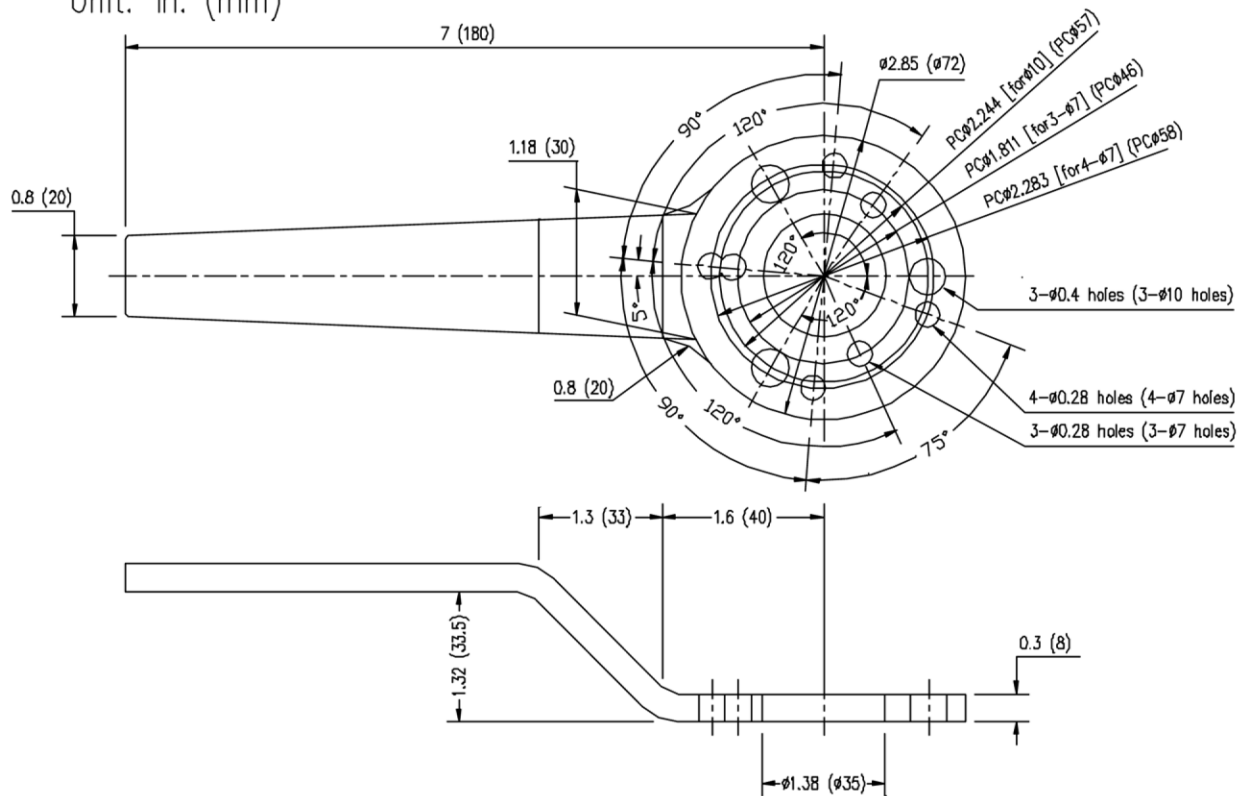

NOTES:

1. DIMENSIONS ARE SHOWN IN INCHES AND DIMENSIONS IN () ARE IN MILLIMETERS.
2. MATERIAL IS STEEL.

Figure 1. Flywheel Locking Handle (P/N: 114250-92101).

END OF TASK

END OF WORK PACKAGE

FIELD MAINTENANCE

2 kW MEP-501A/531A MILITARY TACTICAL GENERATOR SETS

FLYWHEEL EXTRACTOR (P/N: 114250-92130)

INITIAL SETUP:

Not Applicable

P/N 114250-92130

Flywheel Extractor

Material: steel
 Scale: free
 Unit: in. (mm)

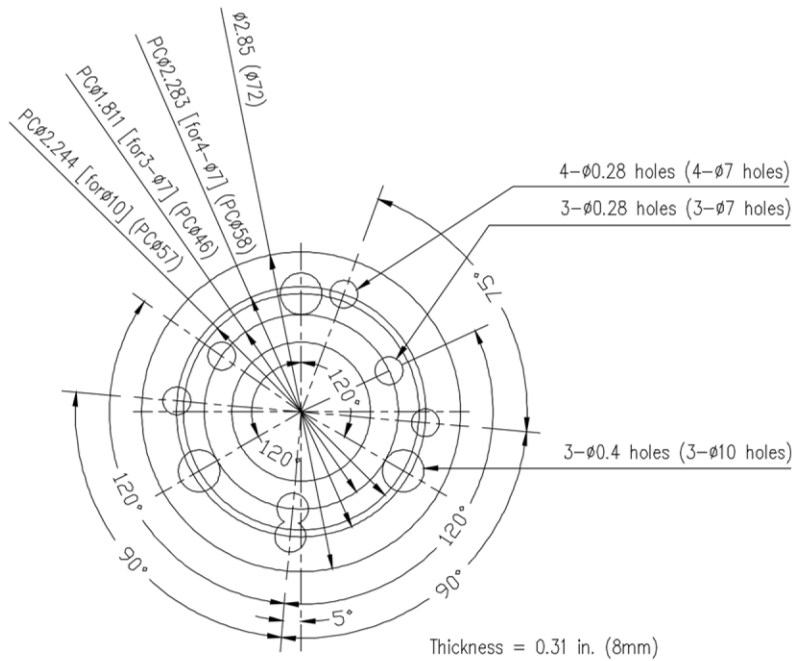

NOTES:

1. DIMENSIONS ARE SHOWN IN INCHES AND DIMENSIONS IN () ARE IN MILLIMETERS.
2. MATERIAL IS STEEL.

Figure 1. Flywheel Extractor (P/N: 114250-92130).

END OF TASK

END OF WORK PACKAGE

FIELD MAINTENANCE

2 kW MEP-501A/531A MILITARY TACTICAL GENERATOR SETS

TORQUE LIMITS

INITIAL SETUP:

Not Applicable

HOW TO USE THE TORQUE TABLES

1. Measure the diameter of the screw you are installing.

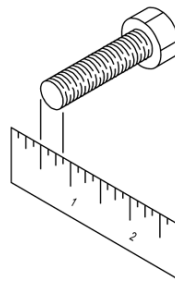

2. Under the heading DIA. INCHES or MM, look down the left hand column until you find the diameter of the screw you are installing.

CAPSCREW HEAD MARKINGS

Manufacturer' s marks may vary.
These are all SAE Grade 5 (3-line).

Metric screws are of three grades:
8.8, 10.9, and 12.9. Grades and manufac-
turer' s marks appear on the screw head.

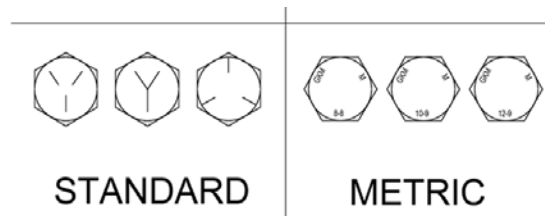

3. To find the grade screw you are installing, match the markings on the head of the screw to the correct picture of the cap screw head markings at the top of the torque table.
4. Look down the column under the picture you found in step 3 until you find the torque limit (FT•LB or N•M) for the diameter of the screw you are installing.

Table 1. Torque Limits for Steel Fasteners.

Dia. (inches)	Torque
4-40	6 in•lb (0.68 N•m)
6-32	11 in•lb (1.2 N•m)
8-32	20 in•lb (2.3 N•m)
10-32	32 in•lb (3.6 N•m)
1/4-20	75 in•lb (8.5 N•m)
5/16-18	140 in•lb (15.8 N•m)
3/8-16	31 ft•lb (42.0 N•m)
1/2-13	75 ft•lb (101.7 N•m)

Torque values shown are for nut-screw combinations that have not been plated or have not had special lubricants applied to them. Discount the residual lubricant present that was applied during manufacture.

Table 2. Torque Limits for Brass Fasteners.

Dia. (inches)	Torque
1/4-20	50 in•lb (5.6 N•m)
1/2-13	35 ft•lb (47.5 N•m)

Torque values shown are for nut-screw combinations that have been plated or have had lubricant applied.

Table 3. Torque Limits for Metric Fasteners into Steel.

Dia. (inches)	Torque
M6 x 1	7.3 ft•lb (9.9 N•m)
M8 x 1.25	18 ft•lb (24.4 N•m)
M10 x 1.5	35 ft•lb (47.5 N•m)

Torque values shown are for nut-screw combinations that have not been plated or have not had special lubricants applied to them. Discount the residual lubricant present that was applied during manufacture.

END OF WORK PACKAGE

CHAPTER 7

OPERATOR AND FIELD PARTS INFORMATION

FOR

2 kW MILITARY TACTICAL GENERATOR SETS

MEP-531A

MEP-501A

CHAPTER 7
PARTS INFORMATION

WORK PACKAGE INDEX

<u>Title</u>	<u>WP Sequence No.</u>
Introduction.....	0116
GROUP 00 Generator Set Assembly, 2 kW (MEP-531A/501A).....	0117
GROUP 01 Frame Assembly (MEP-531A/501A)	0118
GROUP 02 Fuel System Assembly (MEP-531A/501A).....	0119
GROUP 0201 Fuel Tank Assembly.....	0120
GROUP 0202 Fuel Filter Assembly.....	0121
GROUP 03 Engine Alternator Assembly (MEP-531A)	0122
GROUP 03 Engine Alternator Assembly (MEP-501A)	0123
GROUP 0301 Diesel Engine Modified.....	0124
GROUP 030101 Diesel Engine Assembly.....	0125
GROUP 03010101 Cylinder Block Installation	0126
GROUP 03010102 Cylinder Head Installation	0127
GROUP 03010103 Air Intake Pipe and Muffler	0128
GROUP 03010104 Cam/Crankshaft/Balancer Installation.....	0129
GROUP 03010105 Piston and Rod Assembly	0130
GROUP 03010106 Lube Oil Pump and Governor.....	0131
GROUP 03010107 Cooling/Starting Installation.....	0132
GROUP 03010108 Fuel Injection Pump/Injector Installation.....	0133
GROUP 03010109 Starting Motor and Dynamo Installation	0134
GROUP 0302 AC Alternator Assembly (MEP-531A)	0135
GROUP 0303 DC Alternator Assembly (MEP-501A)	0136
GROUP 04 Control Panel Assembly (MEP-531A)	0137
GROUP 04 Control Panel Assembly (MEP-501A)	0138
GROUP 0401 Control Panel Constructions (MEP-531A/501A)	0139
GROUP 0402 Voltage Adjust Potentiometer.....	0140
GROUP 0407 LOP Shutdown Solenoid Assembly.....	0141
GROUP 0408 Control Panel Engine Wiring Harnesses (MEP-531A/501A).....	0142
GROUP 0409 Control Panel Alternator Wiring Harnesses (MEP-531A/501A)	0143
GROUP 0411 Flywheel Diode Assembly	0144
GROUP 0412 Control Panel Electrical Leads (MEP-531A)	0145
GROUP 0412 Control Panel Electrical Leads (MEP-501A)	0146
GROUP 0413 Capacitor Assembly (MEP-501A).....	0147
GROUP 0414 Transient Suppressor Assembly (MEP-501A).....	0148

<u>Title</u>	<u>WP Sequence No.</u>
GROUP 05 Engine Wiring Harness (MEP-531A/501A)	0149
GROUP 06 LOP Engine Shutdown Cable Assembly (MEP-531A/501A).....	0150
GROUP 07 Preheater Lead Assembly (MEP-531A/501A).....	0151
GROUP 08 Alternator Wiring Harness (MEP-501A)	0152
Bulk Items	0153
Special Tools List	0154
NSN Index	0155
P/N Index.....	0156

OPERATOR AND FIELD MAINTENANCE

2 kW MEP-501A/531A MILITARY TACTICAL GENERATOR SETS

INTRODUCTION

SCOPE

This RPSTL lists and authorizes spares and repair parts; special tools; special test, measurement, and diagnostic equipment (TMDE); and other special support equipment required for performance of operator and field maintenance of the 2 kW Military Tactical Generator Sets. It authorizes the requisitioning, issue, and disposition of spares, repair parts, and special tools as indicated by the source, maintenance, and recoverability (SMR) codes.

GENERAL

In addition to the Introduction work package, this RPSTL is divided into the following work packages.

1. **Repair Parts List Work Packages.** Work packages containing lists of spares and repair parts authorized by this RPSTL for use in the performance of maintenance. These work packages also include parts which must be removed for replacement of the authorized parts. Parts lists are composed of functional groups in ascending alphanumeric sequence, with the parts in each group listed in ascending figure and item number sequence. Sending units, brackets, filters, and bolts are listed with the component they mount on. Bulk materials are listed by item name in FIG. BULK at the end of the work packages. Repair parts kits are listed separately in their own functional group and work package. Repair parts for repairable special tools are also listed in a separate work package. Items listed are shown on the associated illustrations.
2. **Special Tools List Work Packages.** Work packages containing lists of special tools, special TMDE, and special support equipment authorized by this RPSTL (as indicated by Basis of Issue (BOI) information in the DESCRIPTION AND USABLE ON CODE (UOC) column). Tools that are components of common tool sets and/or Class VII are not listed.
3. **Cross-Reference Indexes Work Packages.** There are 2 crossreference indexes work packages in this RPSTL: the National Stock Number (NSN) Index work package, and the Part Number (P/N) Index work package. The National Stock Number Index work package refers you to the figure and item number. The Part Number Index work package refers you to the figure and item number.

EXPLANATION OF COLUMNS IN THE REPAIR PARTS LIST AND SPECIAL TOOLS LIST WORK PACKAGES

ITEM NO. (Column (1)). Indicates the number used to identify items called out in the illustration.

SMR CODE (Column (2)). The SMR code containing supply/requisitioning information, maintenance level authorization criteria, and disposition instruction, as shown in the following breakout. This entry may be subdivided into 4 subentries, one for each service.

Table 1. SMR Code Explanation.

<u>Source Code</u>	<u>Maintenance Code</u>	<u>Recoverability Code</u>
XX	XX	X
1st two positions: How to get an item.	3rd position: Who can install, replace, or use the item.	4th position: Who can do complete repair* on the item.
		5th position: Who determines disposition action on unserviceable items.

*Complete Repair: Maintenance capacity, capability, and authority to perform all corrective maintenance tasks of the "Repair" function in a use/user environment in order to restore serviceability to a failed item.

Source Code. The source code tells you how you get an item needed for maintenance, repair, or overhaul of an end item/equipment. Explanations of source codes follow:

Source Code**Application/Explanation**

PA	
PB	
PC	
PD	
PE	
PF	
PG	
PH	
PR	
PZ	
KD	
KF	
KB	
MF-Made at field	
MH-Made at below depot/sustainment level	
ML-Made at SRA	
MD-Made at depot	
MG-Navy only	
AF-Assembled by field	
AH-Assembled by below depot sustainment level	
AL-Assembled by SRA	
AD-Assembled by depot	
AG-Navy only	
XA	
XB	
XC	
XD	

NOTE

Items coded PC are subject to deterioration.

Stock items; use the applicable NSN to requisition/request items with these source codes. They are authorized to the level indicated by the code entered in the third position of the SMR code.

Items with these codes are not to be requested/requisitioned individually. They are part of a kit which is authorized to the maintenance level indicated in the third position of the SMR code. The complete kit must be requisitioned and applied.

Items with these codes are not to be requisitioned/requested individually. They must be made from bulk material which is identified by the part number in the DESCRIPTION AND USABLE ON CODE (UOC) column and listed in the bulk material group work package of the RPSTL. If the item is authorized to you by the third position code of the SMR code, but the source code indicates it is made at higher level, order the item from the higher level of maintenance.

Items with these codes are not to be requested/requisitioned individually. The parts that make up the assembled item must be requisitioned or fabricated and assembled at the level of maintenance indicated by the source code. If the third position of the SMR code authorizes you to replace the item, but the source code indicates the item is assembled at a higher level, order the item from the higher level of maintenance.

Do not requisition an "XA" coded item. Order the next higher assembly. (Refer to NOTE below.)

If an item is not available from salvage, order it using the CAGEC and part number.

Installation drawings, diagrams, instruction sheets, field service drawings; identified by manufacturer's part number.

Item is not stocked. Order an XD-coded item through local purchase or normal supply channels using the CAGEC and part number given, if no NSN is available.

NOTE

Cannibalization or controlled exchange, when authorized, may be used as a source of supply for items with the above source codes except for those items source coded "XA" or those aircraft support items restricted by requirements of AR 750-1.

Maintenance Code. Maintenance codes tell you the level(s) of maintenance authorized to use and repair support items. The maintenance codes are entered in the third and fourth positions of the SMR code as follows:

Third Position. The maintenance code entered in the third position tells you the lowest maintenance level authorized to remove, replace, and use an item. The maintenance code entered in the third position will indicate authorization to the following levels of maintenance:

<u>Maintenance Code</u>	<u>Application/Explanation</u>
F -	Field maintenance can remove, replace, and use the item.
H -	Below Depot Sustainment maintenance can remove, replace, and use the item.
L -	Specialized repair activity can remove, replace, and use the item.
G -	Afloat and ashore intermediate maintenance can remove, replace, and use the item (Navy only)
K -	Contractor facility can remove, replace, and use the item.
Z -	Item is not authorized to be removed, replaced, or used at any maintenance level
D -	Depot can remove, replace, and use the item.

*NOTE - Army may use C in the third position. However, for joint service publications, Army will use O.

Fourth Position. The maintenance code entered in the fourth position tells you whether or not the item is to be repaired and identifies the lowest maintenance level with the capability to do complete repair (perform all authorized repair functions).

NOTE

Some limited repair may be done on the item at a lower level of maintenance, if authorized by the Maintenance Allocation Chart (MAC) and SMR codes.

<u>Maintenance Code</u>	<u>Application/Explanation</u>
F -	Field is the lowest level that can do complete repair of the item.
H -	Below Depot Sustainment is the lowest level that can do complete repair of the item.
L -	Specialized repair activity is the lowest level that can do complete repair of the item.
D -	Depot is the lowest level that can do complete repair of the item.
G -	Both afloat and ashore intermediate levels are capable of complete repair of item. (Navy only)
K -	Complete repair is done at contractor facility
Z -	Nonreparable. No repair is authorized.
B -	No repair is authorized. No parts or special tools are authorized for maintenance of "B" coded item. However, the item may be reconditioned by adjusting, lubricating, etc., at the user level.

Recoverability Code. Recoverability codes are assigned to items to indicate the disposition action on unserviceable items. The recoverability code is shown in the fifth position of the SMR code as follows:

<u>Recoverability Code</u>	<u>Application/Explanation</u>
Z -	Nonreparable item. When unserviceable, condemn and dispose of the item at the level of maintenance shown in the third position of the SMR code.
F -	Reparable item. When uneconomically reparable, condemn and dispose of the item at the field level.
H -	Reparable item. When uneconomically reparable, condemn and dispose of the item at the below depot sustainment level.
D -	Reparable item. When beyond lower level repair capability, return to depot. Condemnation and disposal of item are not authorized below depot level.
L -	Reparable item. Condemnation and disposal not authorized below Specialized Repair Activity (SRA).
A -	Item requires special handling or condemnation procedures because of specific reasons (such as precious metal content, high dollar value, critical material, or hazardous material). Refer to appropriate manuals/directives for specific instructions.
G -	Field level reparable item. Condemn and dispose at either afloat or ashore intermediate levels. (Navy only)
K -	Reparable item. Condemnation and disposal to be performed at contractor facility.

NSN (Column (3)). The NSN for the item is listed in this column.

CAGEC (Column (4)). The Commercial and Government Entity Code (CAGEC) is a five-digit code which is used to identify the manufacturer, distributor, or Government agency/activity that supplies the item.

PART NUMBER (Column (5)). Indicates the primary number used by the manufacturer (individual, company, firm, corporation, or Government activity), which controls the design and characteristics of the item by means of its engineering drawings, specifications, standards, and inspection requirements to identify an item or range of items.

NOTE

When you use an NSN to requisition an item, the item you receive may have a different part number from the number listed.

DESCRIPTION AND USABLE ON CODE (UOC) (Column (6)). This column includes the following information:

1. The federal item name, and when required, a minimum description to identify the item.
2. Part numbers of bulk materials are referenced in this column in the line entry to be manufactured or fabricated.
3. Hardness Critical Item (HCI). A support item that provides the equipment with special protection from electromagnetic pulse (EMP) damage during a nuclear attack.
4. The statement END OF FIGURE appears just below the last item description in column (6) for a given figure in both the repair parts list and special tools list work packages.

QTY (Column (7)). The QTY (quantity per figure) column indicates the quantity of the item used in the breakout shown on the illustration/figure, which is prepared for a functional group, subfunctional group, or an assembly. A "V" appearing in this column instead of a quantity indicates that the quantity is variable and quantity may change from application to application.

EXPLANATION OF CROSS-REFERENCE INDEXES WORK PACKAGES FORMAT AND COLUMNS

1. National Stock Number (NSN) Index Work Package. NSN's in this index are listed in National Item Identification Number (NIIN) sequence.

STOCK NUMBER Column. This column lists the NSN in NIIN sequence. The NIIN consists of the last nine digits of the NSN. When using this column to locate an item, ignore the first four digits of the NSN.

However, the complete NSN should be used when ordering items by stock number.

For example, if the NSN is 5385-01-574-1476, the NIIN is 01-574-1476.

FIG. Column. This column lists the number of the figure where the item is identified/located. The figures are in numerical order in the repair parts list and special tools list work packages.

ITEM Column. The item number identifies the item associated with the figure listed in the adjacent FIG. column. This item is also identified by the NSN listed on the same line.

2. **Part Number (P/N) Index Work Package.** Part numbers in this index are listed in ascending alphanumeric sequence (vertical arrangement of letter and number combinations which places the first letter or digit of each group in order A through Z, followed by the numbers 0 through 9 and each following letter or digit in like order).

PART NUMBER Column. Indicates the part number assigned to the item.

FIG. Column. This column lists the number of the figure where the item is identified/located in the repair parts list and special tools list work packages.

ITEM Column. The item number is the number assigned to the item as it appears in the figure referenced in the adjacent figure number column.

SPECIAL INFORMATION

UOC. The UOC appears in the lower left corner of the Description Column heading. Usable on codes are shown as "UOC: ..." in the Description Column (justified left) on the first line under the applicable item/nomenclature. Uncoded items are applicable to all models. Identification of the UOCs used in the RPSTL are: There is no UOC information supplied for this manual.

Fabrication Instructions. Bulk materials required to manufacture items are listed in the bulk material functional group of this RPSTL. Part numbers for bulk material are also referenced in the Description Column of the line item entry for the item to be manufactured/fabricated. Detailed fabrication instructions for items source coded to be manufactured or fabricated are found in (enter applicable TM number).

Index Numbers. Items which have the word BULK in the figure column will have an index number shown in the item number column. This index number is a cross-reference between the NSN / Part Number (P/N) Index work packages and the bulk material list in the repair parts list work package.

Illustrations List. The illustrations in this RPSTL contain field authorized items. The tabular list in the repair parts list work package contains only those parts coded "F" in the third position of the SMR code, therefore, there may be a break in the item number sequence.

HOW TO LOCATE REPAIR PARTS

1. When NSNs or Part Numbers Are Not Known.

First. Using the table of contents, determine the assembly group to which the item belongs. This is necessary since figures are prepared for assembly groups and subassembly groups, and lists are divided into the same groups.

Second. Find the figure covering the functional group or the subfunctional group to which the item belongs.

Third. Identify the item on the figure and note the number(s).

Fourth. Look in the repair parts list work packages for the figure and item numbers. The NSNs and part numbers are on the same line as the associated item numbers.

2. When NSN Is Known.

First. If you have the NSN, look in the STOCK NUMBER column of the NSN index work package. The NSN is arranged in NIIN sequence. Note the figure and item number next to the NSN.

Second. Turn to the figure and locate the item number. Verify that the item is the one you are looking for.

3. When Part Number Is Known.

First. If you have the part number and not the NSN, look in the PART NUMBER column of the part number index work package. Identify the figure and item number.

Second. Look up the item on the figure in the applicable repair parts list work package.

ABBREVIATIONS

Not Applicable

END OF WORK PACKAGE

OPERATOR AND FIELD MAINTENANCE

2 kW MEP-501A/531A MILITARY TACTICAL GENERATOR SETS
 GROUP 00 GENERATOR SET ASSEMBLY, 2 kW (MEP-531A/501A)

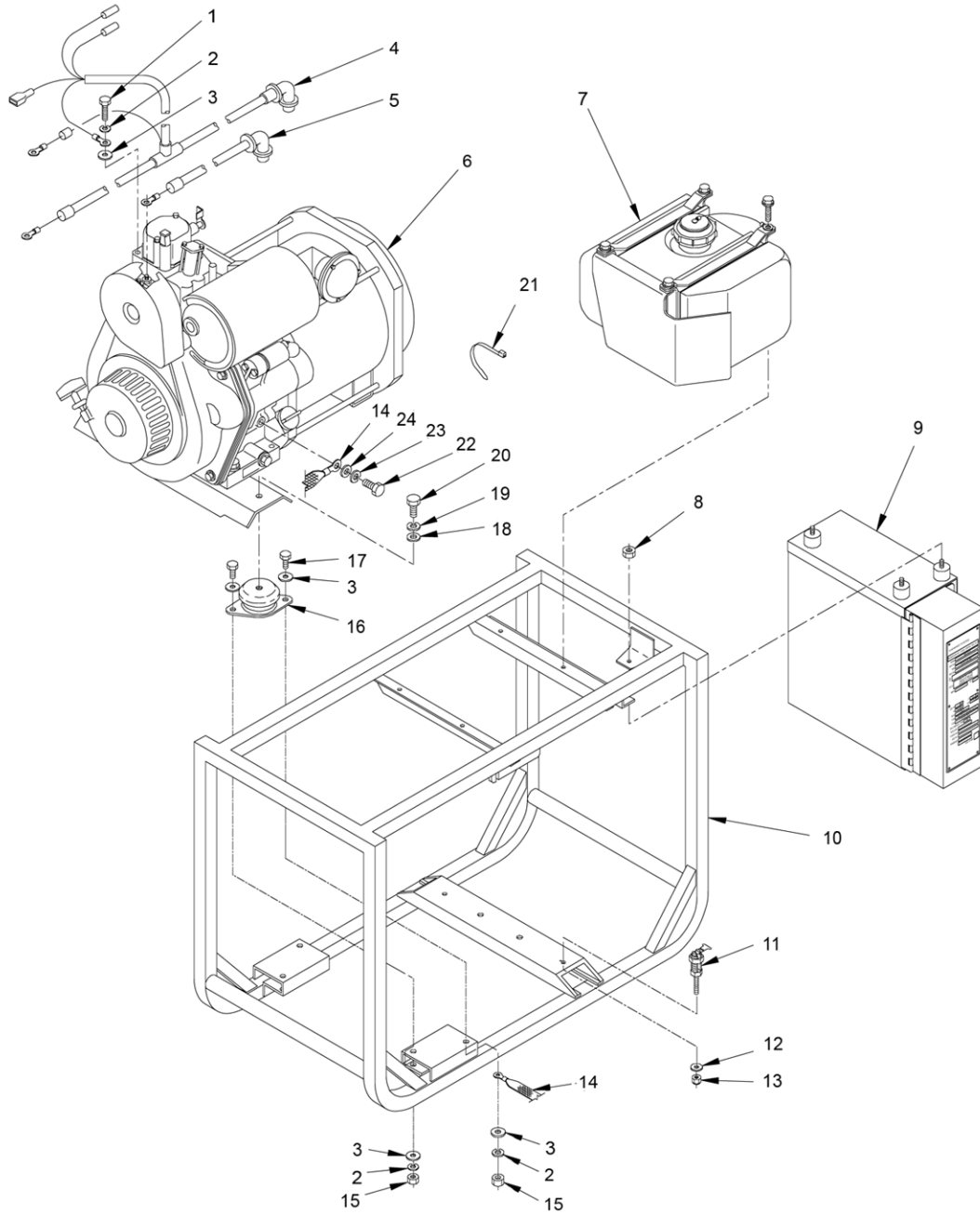
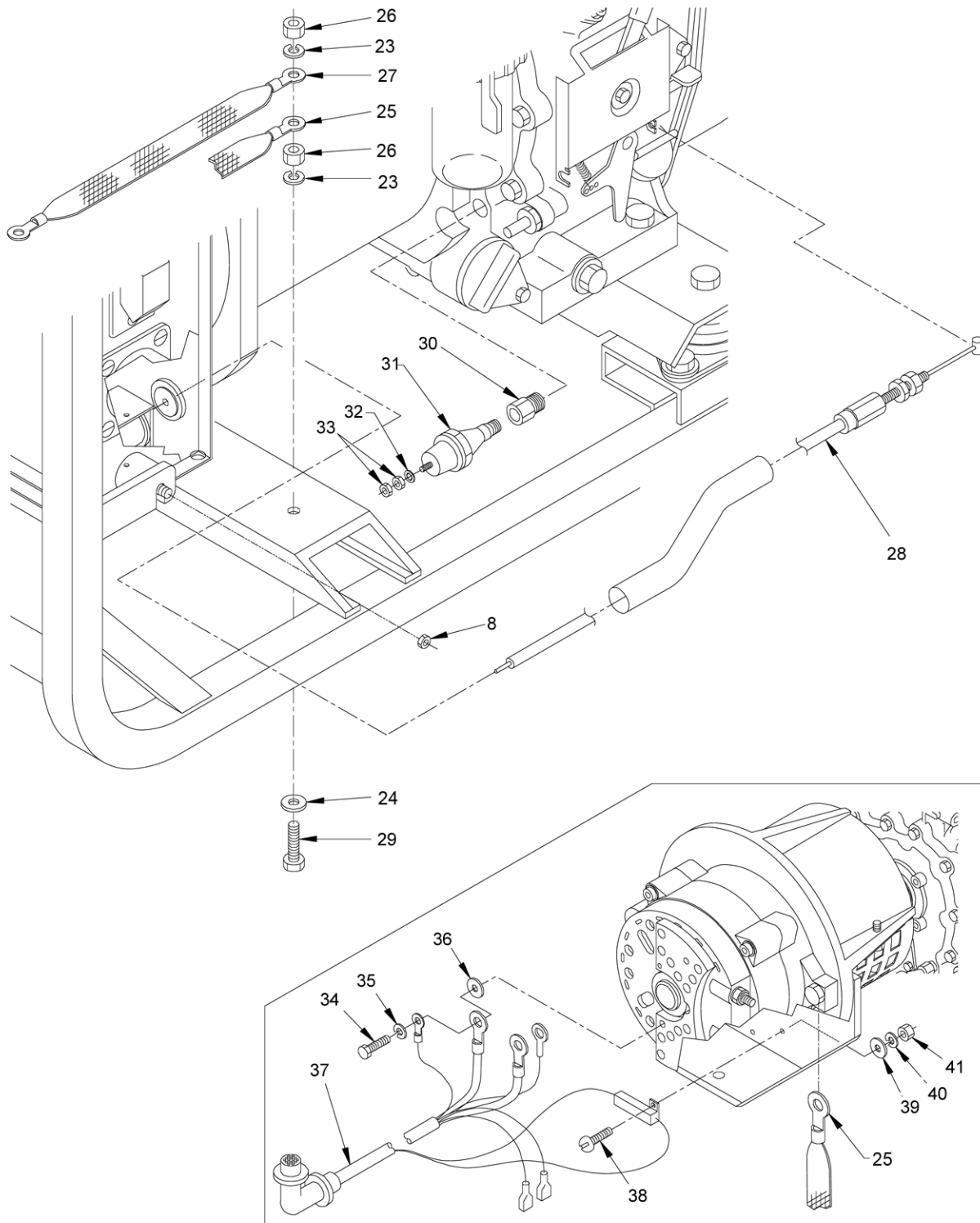

Figure 1. Generator Set Assembly, 2 kW (MEP-531A/501A) (Sheet 1 of 2).



MEP-501A ONLY

Figure 1. Generator Set Assembly, 2 kW (MEP-531A/501A) (Sheet 2 of 2).

(1)	(2)		(3)	(4)	(5)	(6)	(7)
ITEM NO	SMR CODE		NSN	CAGEC	PART NUMBER	DESCRIPTION AND USABLE ON CODE (UOC)	QTY
	a. ARMY	b. AIR FORCE					
GROUP 00 GENERATOR SET ASSEMBLY, 2 KW (MEP-531A/501A)							
FIG. 1 GENERATOR SET ASSEMBLY, 2 KW (MEP-531A/501A)							
1	XBFZZ	XBOZZ	5306-01-423-2038	80204	B18231B08016N	. BOLT, MACHINE	1
2	XBFZZ	XBOZZ		80204	B18212HRCZ080	. WASHER, LOCK- SPRING (MEP-531A).....	7
2	XBFZZ	XBOZZ		80204	B18212HRCZ080	. WASHER, LOCK- SPRING (MEP-501A).....	7
3	XBFZZ	XBOZZ		80204	B1822BH080R	. WASHER, PLAIN (MEP-531A).....	13
3	XBFZZ	XBOZZ		80204	B1822BH080R	. WASHER, PLAIN (MEP-501A).....	13
4	XBFFF	XBOOO		30554	95-8029	. WIRING HARNESS, ENG BREAK- DOWN, SEE FIGURE 33.....	1
5	AOFFF	AOOOO		30554	95-8141	. LEAD, ELECTRICAL BREAK- DOWN, SEE FIGURE 35.....	1
6	XCFFF	XCFFF		30554	95-8064	. ENGINE/ALTERNATOR BREAK- DOWN, SEE FIGURE 6 (MEP-531A)....	1
6	XCFFF	XCFFF		30554	95-8040	. ENGINE/ALTERNATOR BREAK- DOWN, SEE FIGURE 7 (MEP-501A)....	1
7	XCFFF	XCOOO		30554	95-8030	. FUEL SYSTEM ASSEMBLY BREAK- DOWN, SEE FIGURE 3	1
8	XBFZZ	XBOZZ		019L2	79NE-040	. NUT, SELF-LOCKING (MEP-531A)	4
8	XBFZZ	XBOZZ		019L2	79NE-040	. NUT, SELF-LOCKING (MEP-501A)	4
9	XBFFF	XBOFF		30554	95-8005	. CONTROL PANEL ASSY BREAK- DOWN, SEE FIGURE 22 (MEP-501A).....	1
9	XBFFF	XBOFF		30554	95-8021	. CONTROL PANEL ASSY BREAK- DOWN, SEE FIGURE 21 (MEP-531A).....	1
10	XBFFF	XBFFF		30554	95-8000	. FRAME, GENERATOR BREAK- DOWN, SEE FIGURE 2	1
11	PAFZZ	PAOZZ	5940-01-374-3138	11530	588558-01	. TERMINAL, STUD	1
12	XBFZZ	XBOZZ		30554	88-20564-14	. WASHER, FLAT	1
13	XBFZZ	XBOZZ		019L2	79NE-058	. NUT, SELF-LOCKING	1
14	XBFZZ	XBOZZ		30554	95-8024-2	. STRAP, GROUND	1
15	XBFZZ	XBOZZ	5310-01-328-7657	80204	B18241B080	. NUT, PLAIN, HEXAGON (MEP-531A).....	6
15	XBFZZ	XBOZZ	5310-01-328-7657	80204	B18241B080	. NUT, PLAIN, HEXAGON (MEP-501A).....	6
16	PAFZZ	PAOZZ	5342-21-914-6301	39020	RA 40EMB SPECIAL	. MOUNT, RESILIENT (MEP-531A).....	2
16	PAFZZ	PAOZZ	5342-21-914-6301	39020	RA 40EMB SPECIAL	. MOUNT, RESILIENT (MEP-501A).....	3
17	XBFZZ	XBOZZ	5305-01-303-5631	80204	B18231B08020N	. SCREW, CAP, HEXAGON (MEP-531A).....	4
17	XBFZZ	XBOZZ	5305-01-303-5631	80204	B18231B08020N	. SCREW, CAP, HEXAGON (MEP-501A).....	6
18	XBFZZ	XBOZZ	5310-01-436-4437	80204	B1822BH100R	. WASHER, FLAT (MEP-531A).....	2
18	XBFZZ	XBOZZ	5310-01-436-4437	80204	B1822BH100R	. WASHER, FLAT (MEP-501A).....	3
19	XBFZZ	XBOZZ		80204	B18212HRCZ100	. WASHER, LOCK- SPRING (MEP-531A).....	2

(1)	(2)		(3)	(4)	(5)	(6)	(7)
SMR CODE							
ITEM NO	a.	b.	NSN	CAGEC	PART NUMBER	DESCRIPTION AND USABLE ON CODE (UOC)	QTY
	ARMY	AIR FORCE					
19	XBFZZ	XBOZZ		80204	B18212HRCZ100	. WASHER, LOCK-SPRING (MEP-501A).....	3
20	XBFZZ	XBOZZ	5305-01-380-3395	80204	B18231B10025NF	. SCREW, CAP, HEXAGON (MEP-531A).....	2
20	XBFZZ	XBOZZ	5305-01-380-3395	80204	B18231B10025NF	. SCREW, CAP, HEXAGON (MEP-501A).....	3
21	XBFZZ	XBOZZ	5975-00-11-3208	43999	LE127-0011-0005	. STRAP, TIEDOWN, ELEC.	8
22	XBFZZ	XBOZZ		80204	B18231B06014N	. SCREW, HEX CAP	1
23	XBFZZ	XBOZZ		80204	B18212HRCZ060	. WASHER, LOCK-SPRING	3
24	XBFZZ	XBOZZ		80204	B1822BH060R	. WASHER, PLAIN	2
25	XBFZZ	XBOZZ		30554	95-8024-3	. STRAP, GROUND (MEP-531A)	1
25	XBFZZ	XBOZZ		30554	95-8024-5	. STRAP, GROUND (MEP-501A)	1
26	XBFZZ	XBOZZ	5310-01-155-3857	56161	10501762	. NUT, PLAIN, HEXAGON	2
27	XBFZZ	XBOZZ		30554	95-8024-4	. STRAP, GROUND	1
28	AOFFF	AOOOO		30554	95-8082	. CABLE ASSEMBLY, ENG. BREAK-DOWN, SEE FIGURE 34.....	1
29	XBFZZ	XBOZZ	5305-01-435-6260	80204	B18231B06025N	. SCREW, CAP, HEXAGON	1
30	PAFZZ	PAOZZ	4730-00-930-7776	81343	2-2 130139C	. COUPLING, PIPE	1
31	PAFZZ	PAOZZ	5930-01-458-5607	13445	8600-01	. SWITCH, LOW OIL	1
32	XBFZZ	XBOZZ		97403	13230E6744-100	. WASHER, LOCK	1
33	XBFZZ	XBOZZ		30554	95-8159-8	. NUT, PLAIN	2
34	XBFZZ	XBOZZ	5305-01-373-4831	80204	B1821BH025F075N	. SCREW, CAP HEX HEAD	1
35	XBFZZ	XBOZZ	5310-01-467-6832	97403	13230E6744-44	. WASHER, LOCK-SPRING (MEP-531A).....	1
35	XBFZZ	XBOZZ	5310-01-467-6832	97403	13230E6744-44	. WASHER, LOCK-SPRING (MEP-501A).....	1
36	XBFZZ	XBOZZ		30554	88-20564-2	. WASHER, FLAT (MEP-531A).....	1
36	XBFZZ	XBOZZ		30554	88-20564-2	. WASHER, FLAT (MEP-501A).....	1
37	XBFFF	XBOOO		30554	95-8028	. WIRING HARNESS, ENG. BREAK-DOWN, SEE FIGURE 36 (MEP-501A).....	1
38	XBFZZ	XBOZZ		97403	13218E0493-1250PIC	. SCREW, MACHINE	2
39	XBFZZ	XBOZZ		30554	88-20564-23	. WASHER, FLAT	2
40	XBFZZ	XBOZZ		97403	13230E6743-70	. WASHER, LOCK, FLAT	2
41	XBFZZ	XBOZZ		30554	95-8159-1	. NUT, PLAIN	2

END OF FIGURE

OPERATOR AND FIELD MAINTENANCE
2 kW MEP-501A/531A MILITARY TACTICAL GENERATOR SETS
GROUP 01 FRAME ASSEMBLY (MEP-531A/501A)

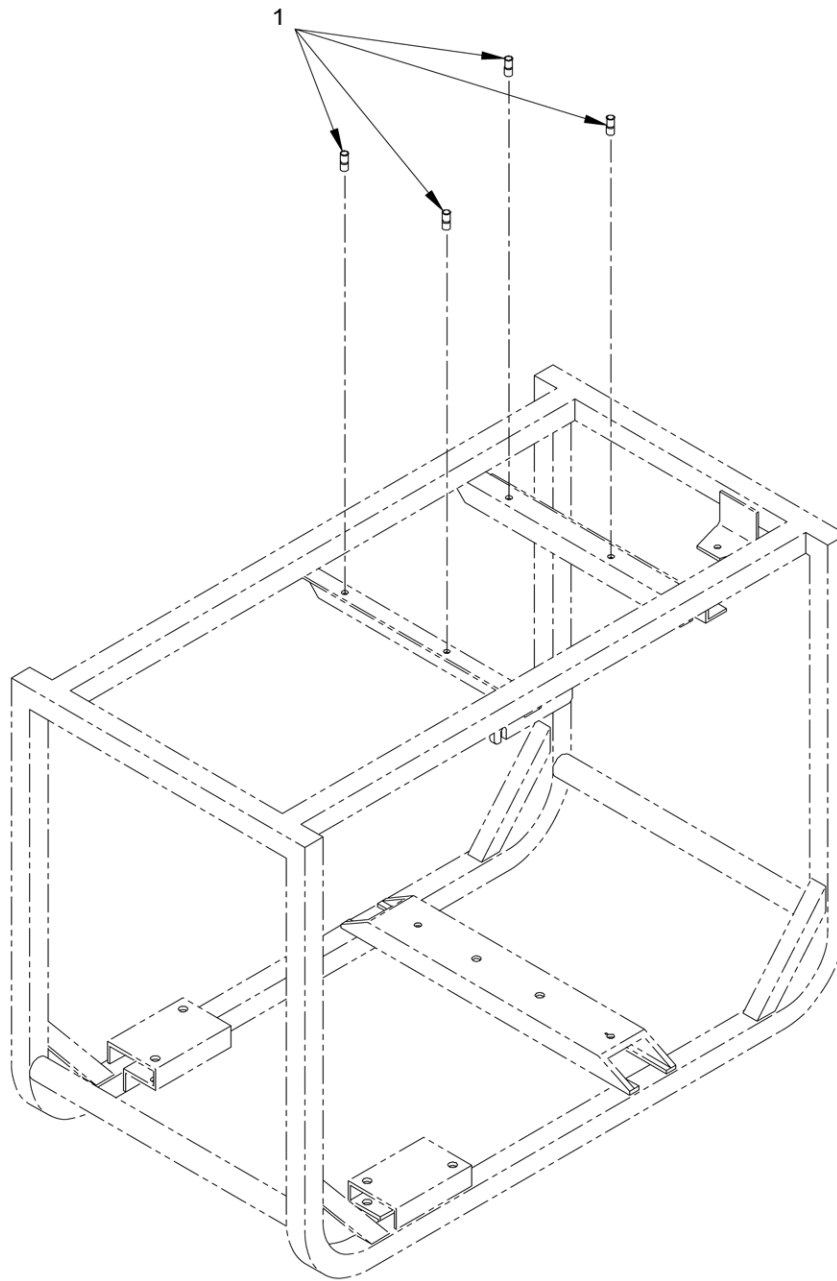

Figure 2. Frame Assembly (MEP-531A/501A).

(1)	(2)		(3)	(4)	(5)	(6)	(7)
ITEM NO	SMR CODE		NSN	CAGEC	PART NUMBER	DESCRIPTION AND USABLE ON CODE (UOC)	QTY
	a. ARMY	b. AIR FORCE					

GROUP 01 FRAME ASSEMBLY
(MEP-531A/501A)

FIG. 2 FRAME ASSEMBLY
(MEP-531A/501A)

1	XBFZZ	XBOZZ		19738	9667-1018	. INSERT, THREADED	4
---	-------	-------	--	-------	-----------	--------------------------	---

END OF FIGURE

OPERATOR AND FIELD MAINTENANCE
2 kW MEP-501A/531A MILITARY TACTICAL GENERATOR SETS
GROUP 02 FUEL SYSTEM ASSEMBLY (MEP-531A/501A)

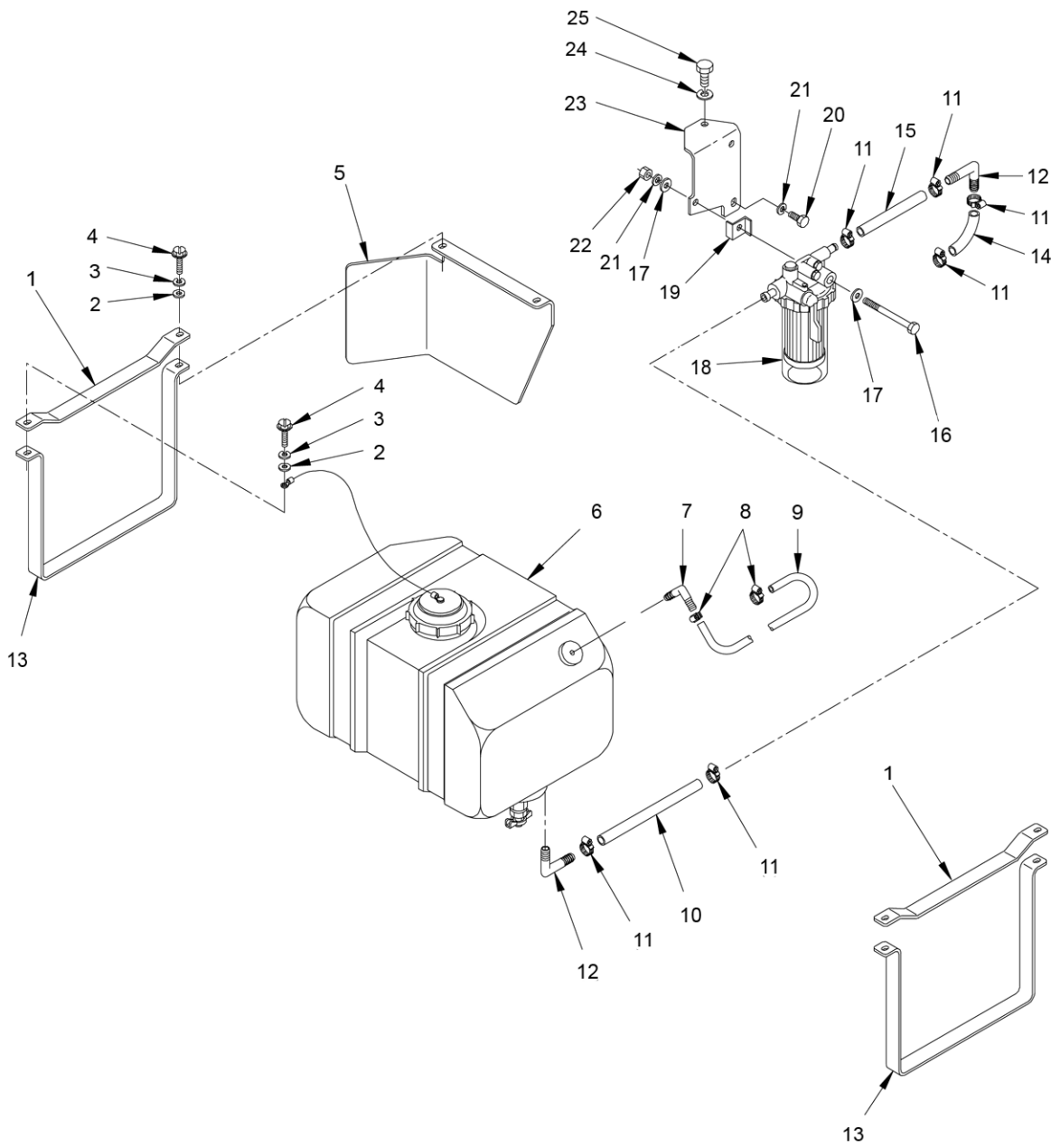

Figure 3. Fuel System Assembly (MEP-531A/501A).

(1)	(2)		(3)	(4)	(5)	(6)	(7)
ITEM NO	SMR CODE		NSN	CAGEC	PART NUMBER	DESCRIPTION AND USABLE ON CODE (UOC)	QTY
	a. ARMY	b. AIR FORCE					
GROUP 02 FUEL SYSTEM ASSEMBLY (MEP-531A/501A)							
FIG. 3 FUEL SYSTEM ASSEMBLY (MEP-531A/501A)							
1	XBFZZ	XBOZZ		30554	95-8035	. BRACKET, FUEL TANK	2
2	XBFZZ	XBOZZ		30554	88-20564-1	. WASHER, FLAT	4
3	XBFZZ	XBOZZ		97403	13230E6744-43	. WASHER, LOCK-SPRING	4
4	XBFZZ	XBOZZ	5305-01-365-6314	30554	88-20260-25	. SCREW, CAP, HEXAGON	4
5	XBFZZ	XBOZZ		30554	95-8039	. GUARD, FUEL TANK	1
6	XBFFF	XBOOO		30554	95-8031	. FUEL TANK ASSEMBLY BREAK-DOWN, SEE FIGURE 4	1
7	XBFZZ	XBOZZ		98883	414 580 600	. ELBOW, REDUCING	1
8	XBFZZ	XBOZZ	4730-00-071-7890	81343	SAEJ1508	. HOSE, CLAMP, TYPE M	2
9	MOFZZ	MOOZZ		30554	95-8030-27	. TUBING, FLEXIBLE MAKE FROM AEM02012, WP 0153, BULK, ITEM 3, 9-3/4 IN. REQUIRED	1
10	MOFZZ	MOOZZ		30554	95-8030-25	. TUBING, FLEXIBLE MAKE FROM AEM02022, WP 0153, BULK, ITEM 2, 3-1/2 IN. REQUIRED	1
11	XBFZZ	XBOZZ		3S708	331-003	. CLAMP, HOSE	6
12	XBFZZ	XBOZZ		98883	414 650 200	. ELBOW, HOSE FITTING	2
13	XBFZZ	XBOZZ		30554	95-8036	. BRACKET, FUEL TANK	2
14	MOFZZ	MOOZZ		30554	95-8030-20	. TUBING, FLEXIBLE MAKE FROM AEM02022, WP 0153, BULK, ITEM 2, 2 IN. REQUIRED	1
15	MOFZZ	MOOZZ		30554	95-8030-18	. TUBING, FLEXIBLE MAKE FROM AEM02022, WP 0153, BULK, ITEM 2, 3-11/16 IN. REQUIRED	1
16	XBFZZ	XBOZZ		80204	B18231B06070N	. SCREW, CAP HEX HEAD	1
17	XBFZZ	XBOZZ		80204	B1822BH060R	. WASHER, PLAIN	2
18	PAFFF	PAOOO	2910-01-488-7002	0AK42	114789-55500	. FILTER, FUEL ASSEMBLY BREAK-DOWN, SEE FIGURE 5	1
19	XBFZZ	XBOZZ		30554	95-8038	. WASHER, FUEL FILTER	1
20	XBFZZ	XBOZZ	5305-01-300-6263	80204	B18231B06016N	. SCREW, CAP HEXAGON	1
21	XBFZZ	XBOZZ		80204	B18212HRCZNO60	. WASHER, LOCK-SPRING	2
22	XBFZZ	XBOZZ	5310-01-155-3857	56161	10501762	. NUT, PLAIN, HEXAGON	1
23	XBFZZ	XBOZZ	4330-01-467-6774	30554	95-8037	. BRACKET, FUEL FILTER	1
24	XBFZZ	XBOZZ		80204	B18212HRCZ080	. WASHER, LOCK-SPRING (MEP-531A).....	1
24	XBFZZ	XBOZZ		80204	B18212HRCZ080	. WASHER, LOCK-SPRING (MEP-501A).....	1
25	XBFZZ	XBOZZ		80204	B18231B08016N	. BOLT, MACHINE	1

END OF FIGURE

OPERATOR AND FIELD MAINTENANCE
2 kW MEP-501A/531A MILITARY TACTICAL GENERATOR SETS
GROUP 0201 FUEL TANK ASSEMBLY

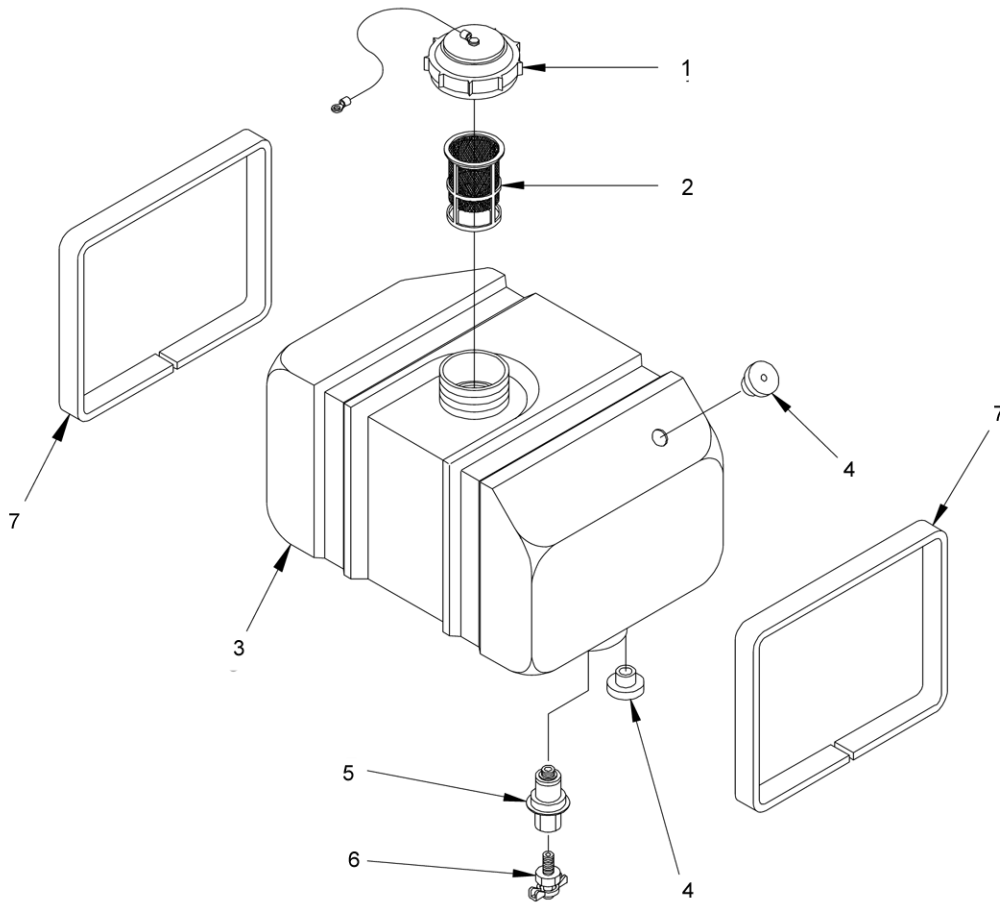

Figure 4. Fuel Tank Assembly.

(1)	(2)		(3)	(4)	(5)	(6)	(7)
ITEM NO	SMR CODE		NSN	CAGEC	PART NUMBER	DESCRIPTION AND USABLE ON CODE (UOC)	QTY
	a. ARMY	b. AIR FORCE					

GROUP 0201 FUEL TANK ASSEMBLY

FIG. 4 FUEL TANK ASSEMBLY

1	XBFZZ	XBOZZ	2990-01-467-7570	30554	95-8033	. FUEL TANK CAP ASSY	1
2	PAFZZ	PAOZZ	4240-01-328-4878	0AK42	114250-55100	. FILTER, GAS	1
3	XBFZZ	XBOZZ	2910-01-497-1023	30554	95-8032	. TANK, FUEL	1
4	XBFZZ	XBOZZ	5365-01-479-1380	30554	95-8137	. BUSHING, RUBBER	2
5	XBFZZ	XBOZZ	4820-01-480-0846	59647	57558	. ADAPTER, DRAIN, FUEL	1
6	PAFZZ	PAOZZ	4820-00-495-9680	04627	12878	. COCK, DRAIN	1
7	MOFZZ	MOOZZ		30554	95-8031-4	. RUBBER, CLOSED-CELL MAKE FROM ASTM D 1056, WP 0153, BULK, ITEM 1, APPROX. 28 IN. REQUIRED	2

END OF FIGURE

OPERATOR AND FIELD MAINTENANCE
2 KW MEP-501A/531A MILITARY TACTICAL GENERATOR SETS
GROUP 0202 FUEL FILTER ASSEMBLY

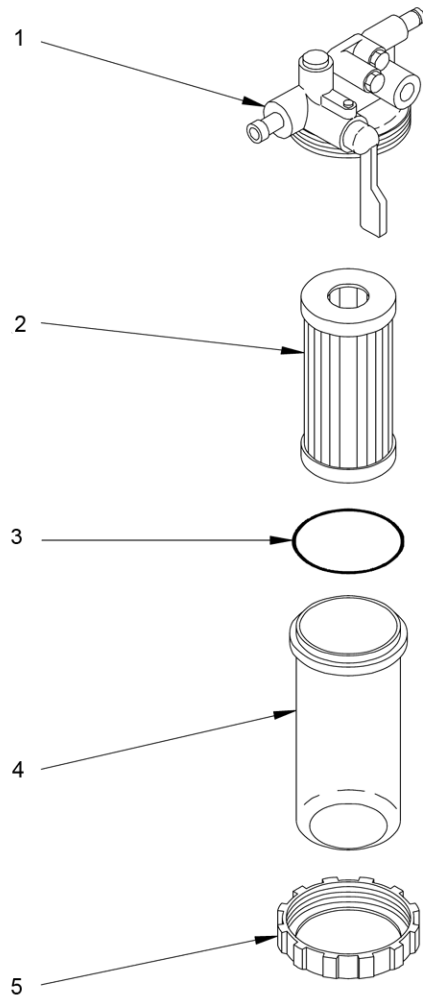

Figure 5. Fuel Filter Assembly.

(1)	(2)		(3)	(4)	(5)	(6)	(7)
ITEM NO	SMR CODE		NSN	CAGEC	PART NUMBER	DESCRIPTION AND USABLE ON CODE (UOC)	QTY
	a. ARMY	b. AIR FORCE					

GROUP 0202 FUEL FILTER ASSEMBLY

FIG. 5 FUEL FILTER ASSEMBLY

1	XAFZZ	XAOZZ		0AK42	HEAD-1	. HEAD, FILTER	1
2	PAFZZ	PAOZZ		0AK42	114250-55510	. FILTER ELEMENT	1
3	PAFZZ	PAOZZ		0AK42	102103-55520	. O-RING	1
4	PAFZZ	PAOZZ		0AK42	124064-55510	. BOWL, SEDIMENT	1
5	XBFZZ	XBOZZ	5340-01-419-5478	0AK42	114250-55610	. RETAINER	1

END OF FIGURE

OPERATOR AND FIELD MAINTENANCE

2 kW MEP-501A/531A MILITARY TACTICAL GENERATOR SETS

GROUP 03 ENGINE ALTERNATOR ASSEMBLY (MEP-531A)

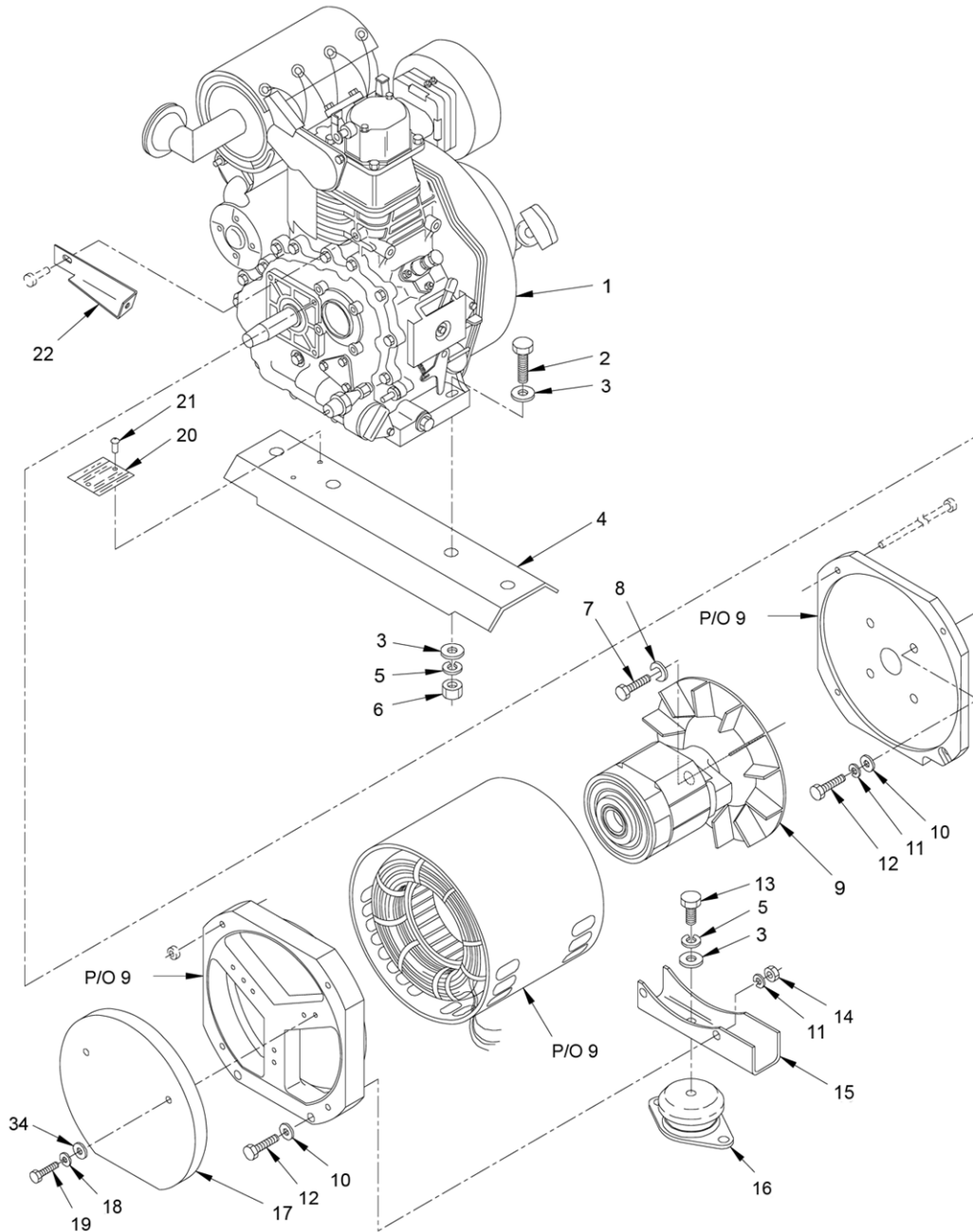

Figure 6. Engine Alternator Assembly (MEP-531A) (Sheet 1 of 2).

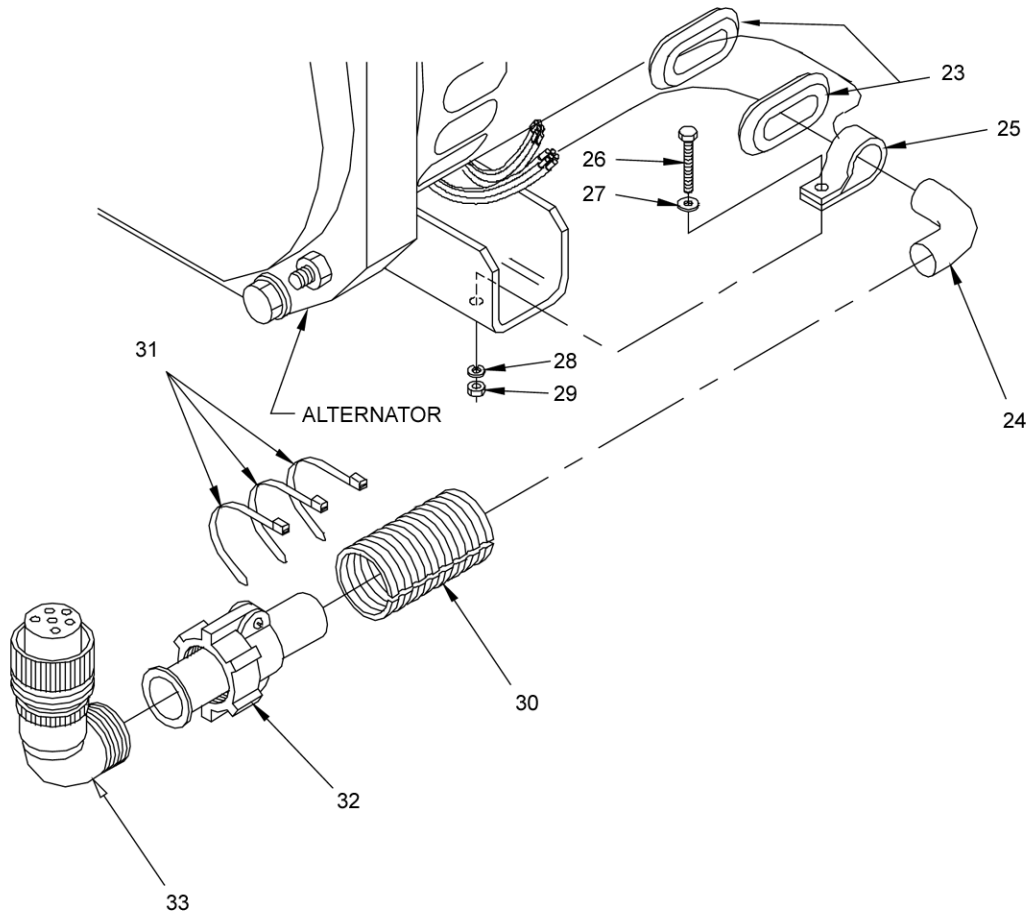

Figure 6. Engine Alternator Assembly (MEP-531A) (Sheet 2 of 2).

(1)	(2)		(3)	(4)	(5)	(6)	(7)
ITEM NO	SMR CODE		NSN	CAGEC	PART NUMBER	DESCRIPTION AND USABLE ON CODE (UOC)	QTY
	a. ARMY	b. AIR FORCE					
GROUP 03 ENGINE ALTERNATOR ASSEMBLY (MEP-531A)							
FIG. 6 ENGINE ALTERNATOR ASSEMBLY (MEP-531A)							
1	XCFFF	XCFFF		30554	95-8055	. ENGINE DIESEL, 4.7 BREAK-DOWN, SEE FIGURE 8	1
2	XBFZZ	XBFZZ	5306-01-419-4096	80204	B18231B10040N	. BOLT, MACHINE	2
3	PAFZZ	PAFZZ		80204	B1822BH100R	. WASHER, FLAT	5
4	XBFZZ	XBFZZ		30554	95-8043	. BRACKET, ENGINE MOUNT	1
5	XBFZZ	XBFZZ		80204	B18212HRCZ100	. WASHER, LOCK-SPRING	3
6	XBFZZ	XBFZZ	5310-01-366-3539	80204	B18241B100	. NUT, PLAIN, HEXAGON	2
7	XBFZZ	XBFZZ	5306-00-050-1238	80204	B1821BH031F075N	. BOLT, MACHINE	1
8	PAFZZ	PAFZZ	5310-01-319-8589	51879	390-00000	. C-WASHER	1
9	PAFFF	PAFFF		35537	D02134	. ALTERNATOR, 120 VAC BREAK-DOWN, SEE FIGURE 19.....	1
10	XBFZZ	XBOZZ		80204	B1822BH080R	. WASHER, PLAIN	6
11	XBFZZ	XBOZZ		80204	B18212HRCZ080	. WASHER, LOCK-SPRING	6
12	XBFZZ	XBFZZ	5306-01-300-6265	80204	B18231B08030N	. BOLT, MACHINE	6
13	PAFZZ	PAOZZ	5305-01-380-3395	80204	B18231B10025NF	. SCREW, CAP, HEXAGON	1
14	PAFZZ	PAOZZ	5310-01-328-7657	80204	B18241B080	. NUT, PLAIN, HEXAGON	2
15	XBFZZ	XBFZZ		30554	95-8065	. BRACKET, ALTERNATOR	1
16	PAFZZ	PAOZZ	5342-21-914-6301	39020	RA 40EMB SPECIAL	. MOUNT, RESILIENT	1
17	XBFZZ	XBOZZ		30554	95-8073	. GUARD, ALTERNATOR	1
18	PAFZZ	PAOZZ	5310-01-467-6832	97403	13230E6744-44	. WASHER, LOCK-SPRING	2
19	PAFZZ	PAOZZ	5305-00-068-0509	80204	B1821BH025C125N	. SCREW, CAP, HEXAGON	2
20	XBFZZ	XBOZZ		30554	95-8061	. PLATE, INSTRUCTION	1
21	XBFZZ	XBOZZ	5320-00-882-8388	81349	M24243/6-A403H	. RIVET, BLIND	2
22	PAFZZ	PAOZZ	4330-01-468-5065	30554	95-8045	. STIFFENER, FUEL FILTER	1
23	XBFZZ	XBFZZ	5325-00-281-1557	70485	AN931-10-14	. GROMMET, NONMETALLIC	2
24	MFFZZ	MFFZZ		30554	95-8064-29	. SLEEVING, INSULATION MAKE FROM ST-301-1/2 BLACK, WP 0153, BULK, ITEM 6, APPROX. 4 IN. REQ.	1
25	XBFZZ	XBFZZ		22175	44LC76WDC-10YN	. CLAMP, LOOP	1
26	XBFZZ	XBFZZ		97403	13218E0493-2769PIC	. SCREW, MACHINE	1
27	XBFZZ	XBFZZ		30554	88-20564-18	. WASHER, FLAT	1
28	XBFZZ	XBFZZ		97403	13230E6744-138	. WASHER, LOCK	1
29	XBFZZ	XBFZZ		30554	95-8159-8	. NUT, HEX, PLAIN	1
30	MFFZZ	MFFZZ		30554	95-8064-25	. TUBING, CONVOLUTED MAKE FROM 012FEJSX000-0XBS, WP 0153, BULK, ITEM 5, 12 IN. REQUIRED	1
31	XBFZZ	XBFZZ	5975-00-111-3208	43999	LE127-0011-0005	. STRAP, TIEDOWN, ELEC.	3
32	XBFZZ	XBFZZ		71468	M85049/41-12A WITH BUSHING	. CLAMP, CABLE, ELEC.	1
33	XBFZZ	XBFZZ		71468	CA3108R20-15S-F80	. CONNECTOR, PLUG, ELEC.	1
34	XBFZZ	XBOZZ		30554	88-20564-2	. WASHER, FLAT	2

END OF FIGURE

OPERATOR AND FIELD MAINTENANCE
2 kW MEP-501A/531A MILITARY TACTICAL GENERATOR SETS
GROUP 03 ENGINE ALTERNATOR ASSEMBLY (MEP-501A)

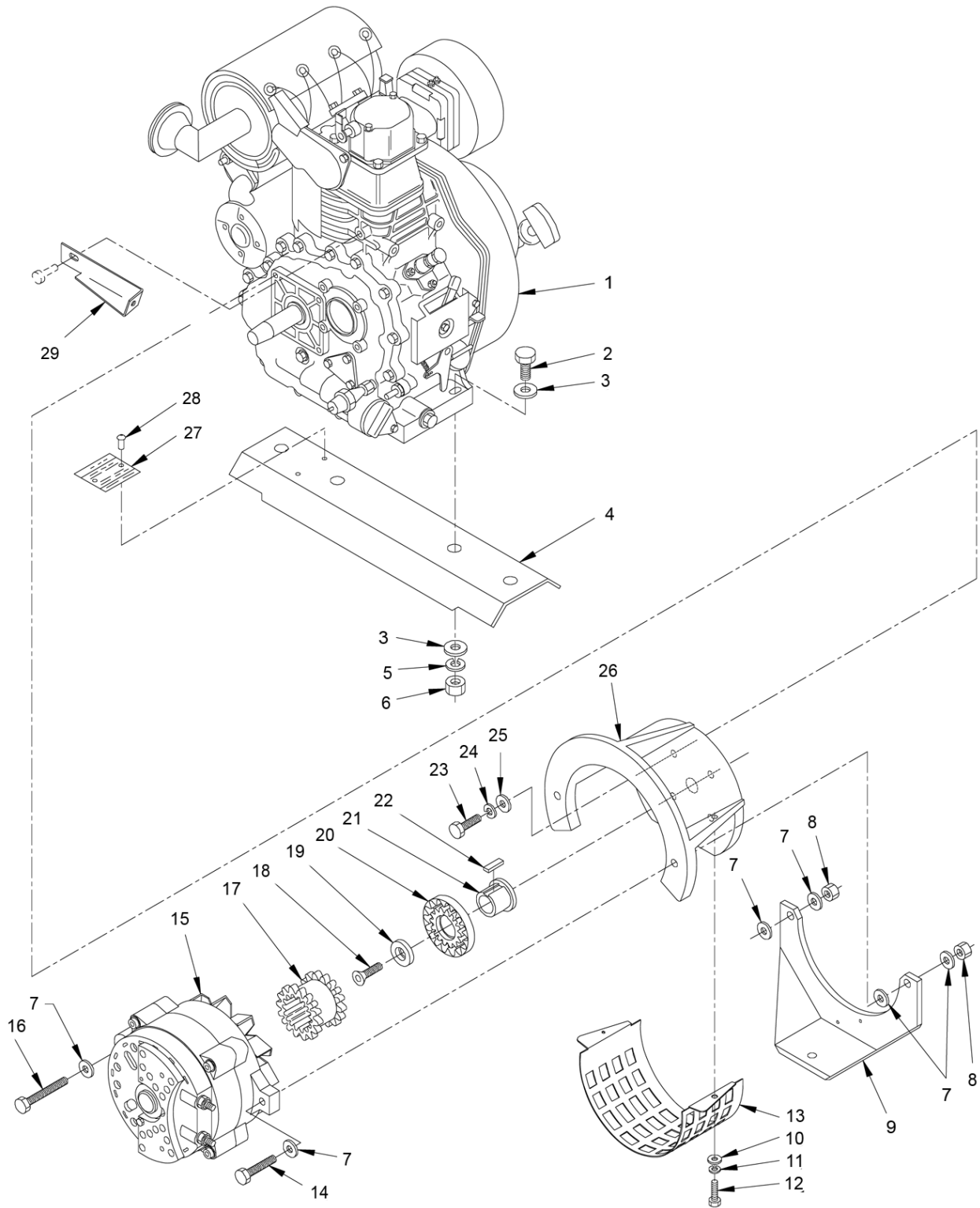

Figure 7. Engine Alternator Assembly (MEP-501A).

(1)	(2)		(3)	(4)	(5)	(6)	(7)
ITEM NO	SMR CODE		NSN	CAGEC	PART NUMBER	DESCRIPTION AND USABLE ON CODE (UOC)	QTY
	a. ARMY	b. AIR FORCE					
GROUP 03 ENGINE ALTERNATOR ASSEMBLY (MEP-501A)							
FIG. 7 ENGINE ALTERNATOR ASSEMBLY (MEP-501A)							
1	XCFFF	XCFFF		30554	95-8055	. ENGINE DIESEL, 4.7 BREAK-DOWN, SEE FIGURE 8	1
2	XBFZZ	XBFZZ	5306-01-419-4096	80204	B18231B10040N	. BOLT, MACHINE	2
3	PAFZZ	PAFZZ		80204	B1822BH100R	. WASHER, FLAT	4
4	XBFZZ	XBFZZ		30554	95-8043	. BRACKET, ENGINE MOUNT	1
5	XBFZZ	XBFZZ		80204	B18212HRCZ100	. WASHER, LOCK-SPRING	2
6	XBFZZ	XBFZZ	5310-01-366-3539	80204	B18241B100	. NUT, PLAIN, HEXAGON	2
7	XBFZZ	XBFZZ		30554	88-20564-22	. WASHER, FLAT	6
8	XBFZZ	XBFZZ		019L2	79NE-066	. NUT, SELF-LOCKING	2
9	XBFZZ	XBFZZ		30554	95-8042	. BRACKET, ALTERNATOR	1
10	XBFZZ	XBFZZ		30554	88-20564-24	. WASHER, FLAT	2
11	PAFZZ	PAOZZ		97403	13230E6744-42	. WASHER, LOCK-SPRING	2
12	XBFZZ	XBFZZ		30554	95-8040-8	. SCREW, HEX WASHERHD	2
13	XBFZZ	XBOZZ		30554	95-8041	. GUARD, ALTERNATOR	1
14	XBFZZ	XBFZZ	5305-00-543-2866	80204	B1821BH038C250N	. SCREW, CAP HEX HEAD	1
15	XCFFF	XCFFF	6115-01-419-3193	0L9X3	10-94-24-M2-PC	. ALTERNATOR, 28 VDC BREAK-DOWN SEE FIGURE 20	1
16	XBFZZ	XBFZZ	5305-00-990-8632	80204	B1821BH038C375N	. SCREW, CAP HEX HEAD	1
17	PAFZZ	PAFZZ	3010-01-149-7959	79425	4JE	. COUPLING SLEEVE	1
18	XBFZZ	XBFZZ		0L9X3	20-TS-0246042	. SCREW, FLAT HEAD	1
19	XBFZZ	XBFZZ		30554	95-8127	. WASHER, FLAT, COUNT	1
20	XBFZZ	XBFZZ		79425	4J X1.000	. FLANGE, FLEXIBLE	1
21	XBFZZ	XBFZZ		30554	95-8003	. ADAPTER, CRANKSHAFT	1
22	XBFZZ	XBFZZ		30554	95-8004	. KEY, MACHINE	1
23	XBFZZ	XBFZZ		80204	B18231B08024N	. BOLT, MACHINE	4
24	XBFZZ	XBOZZ		80204	B18212HRCZ080	. WASHER, LOCK-SPRING	4
25	XBFZZ	XBOZZ		80204	B1822BH080R	. WASHER, PLAIN	4
26	XBFZZ	XBFZZ		0L9X3	20-277-M	. ADAPTER, ENGINE	1
27	XBFZZ	XBOZZ		30554	95-8061	. PLATE, INSTRUCTION	1
28	XBFZZ	XBOZZ	5320-00-882-8388	81349	M24243/6-A403H	. RIVET, BLIND	2
29	XBFZZ	XBOZZ	4330-01-468-5065	30554	95-8045	. STIFFENER, FUEL FILTER	1

END OF FIGURE

OPERATOR AND FIELD MAINTENANCE
2 kW MEP-501A/531A MILITARY TACTICAL GENERATOR SETS
GROUP 0301 DIESEL ENGINE MODIFIED

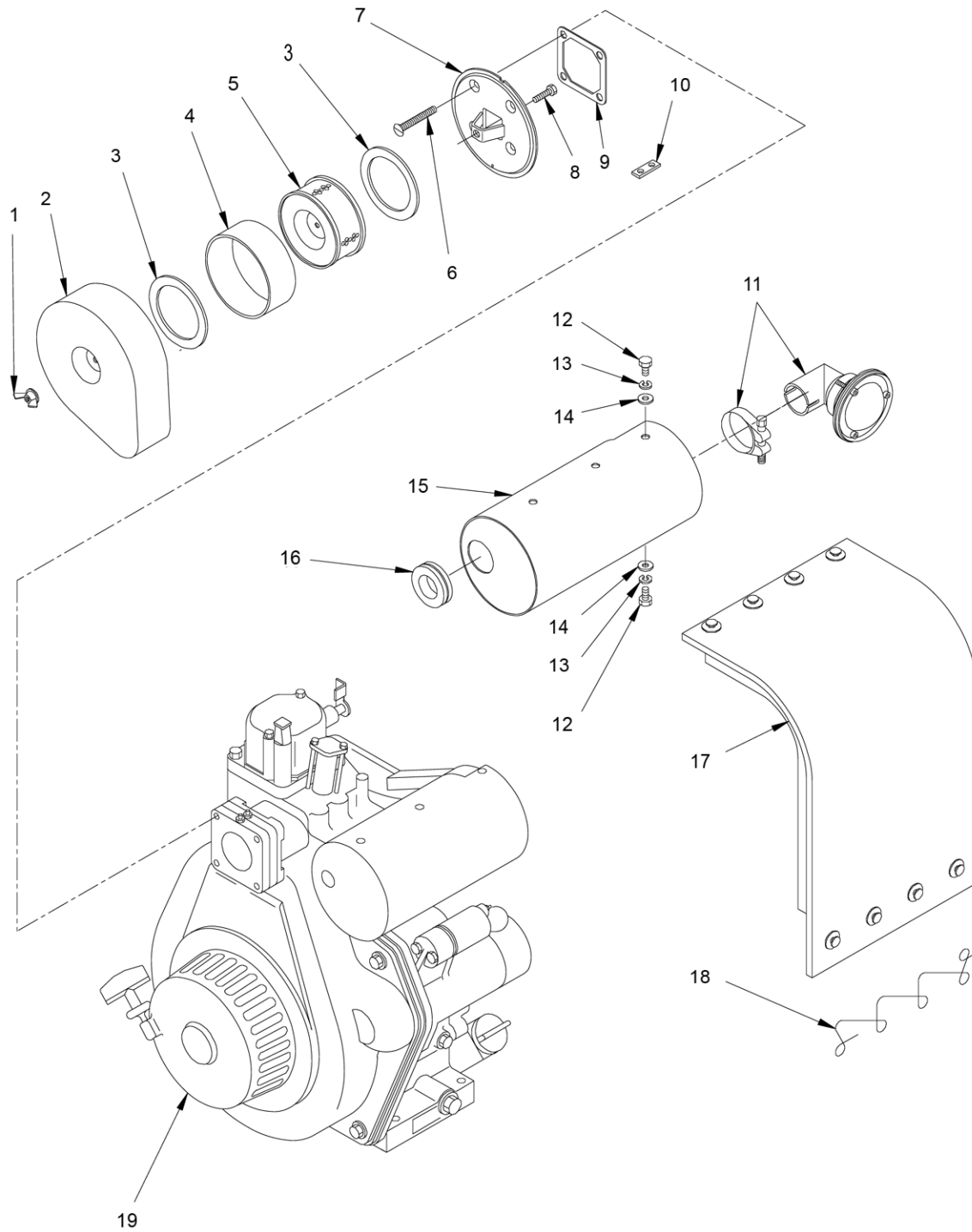

Figure 8. Diesel Engine Modified.

(1)	(2)		(3)	(4)	(5)	(6)	(7)
ITEM NO	SMR CODE		NSN	CAGEC	PART NUMBER	DESCRIPTION AND USABLE ON CODE (UOC)	QTY
	a. ARMY	b. AIR FORCE					
GROUP 0301 DIESEL ENGINE MODIFIED							
FIG. 8 DIESEL ENGINE MODIFIED							
1	PAFZZ	PAOZZ	5310-01-467-2665	97403	13227E6348-9	. NUTWING, WASHER	1
2	XBFZZ	XBOZZ		30554	95-8054	. COVER, AIRFILTER	1
3	PAFZZ	PAOZZ	5330-01-472-5601	83104	95-8053-1	. GASKET, AIRFILTER	2
4	PAFZZ	PAOZZ		0AK42	114250-12580F	. FILTER, ELEMENT	1
5	PAFZZ	PAOZZ	2490-01-310-4495	0AK42	114250-12580	. FILTER, ELEMENT	1
6	XBFZZ	XBOZZ		80204	B1867BA080550	. SCREW, MACHINE	4
7	XBFZZ	XBOZZ		30554	95-8052	. PLATE, MOUNTING	1
8	XBFZZ	XBOZZ		97403	13218E0493-1375PIC	. SCREW, MACHINE	1
9	PAFZZ	PAOZZ	5330-01-467-6273	30554	95-8051	. GASKET, AIRFILTER	1
10	XBFZZ	XBOZZ		30554	95-8057	. JUMPER, AIRHEATER	1
11	PAFZZ	PAOZZ	5950-01-467-3238	0LPU3	3S1125C3BE3	. SPARK ARRESTER	1
12	XBFZZ	XBOZZ	5305-01-300-6264	80204	B18231B06012N	. SCREW, CAP, HEXAGON	6
13	XBFZZ	XBOZZ		80204	B18212HRCZ060	. WASHER, LOCK-SPRING	6
14	XBFZZ	XBOZZ		80204	B1822BH060R	. WASHER, PLAIN	6
15	XBFZZ	XBOZZ		30554	95-8049	. SHROUD, MUFFLER	1
16	PAFZZ	PAOZZ	5325-00-276-6343	96906	MS35489-23	. GROMMET, NONMETALLIC	1
17	PAFZZ	PAOZZ	3110-01-467-7863	77227	TA97-0030	. BLANKET, MUFFLER	1
18	MOFZZ	MOOZZ		30554	95-8055-11	. WIRE, RETAINING MAKE FROM SAE 30305, WP 0153, BULK, ITEM 4, 56-1/4 INCHES REQUIRED.....	1
19	PAFFF	PAFFF		0AK42	L48AE-DEG	. ENGINE, DIESEL, AIR BREAK-DOWN, SEE FIGURE 9	1

END OF FIGURE

OPERATOR AND FIELD MAINTENANCE
2 kW MEP-501A/531A MILITARY TACTICAL GENERATOR SETS
GROUP 030101 DIESEL ENGINE ASSEMBLY

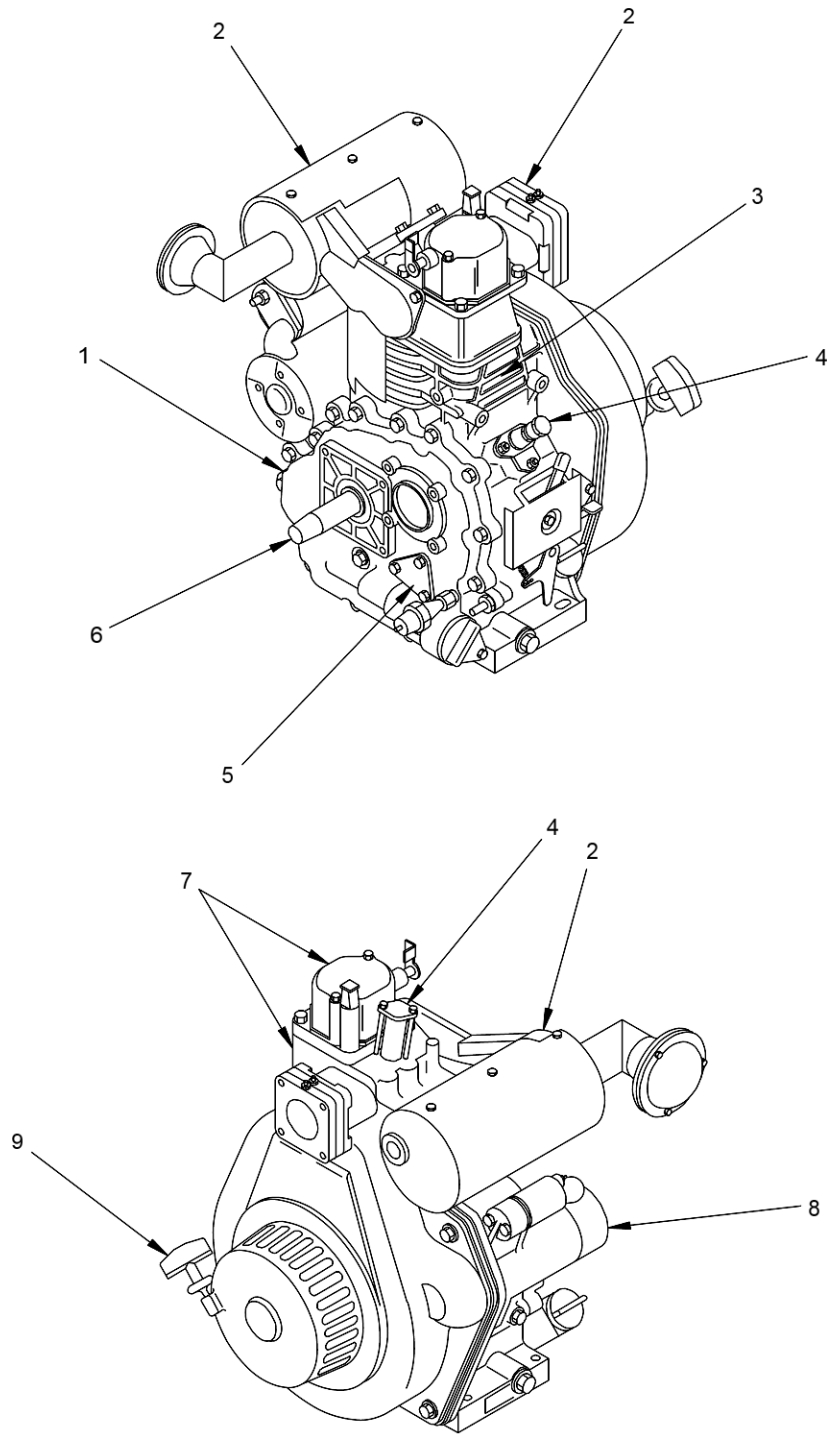

Figure 9. Diesel Engine Assembly.

(1)	(2)		(3)	(4)	(5)	(6)	(7)
ITEM NO	SMR CODE		NSN	CAGEC	PART NUMBER	DESCRIPTION AND USABLE ON CODE (UOC)	QTY
	a. ARMY	b. AIR FORCE					
GROUP 030101 DIESEL ENGINE ASSEMBLY							
FIG. 9 DIESEL ENGINE ASSEMBLY							
1	XCFFF	XCFFF		0AK42	1B03	. CYLINDER BLOCK BREAK-DOWN, SEE FIGURE 10.....	1
2	XCFZZ	XCFZZ		0AK42	1B05	. AIR CLEANER & MUFFL BREAK-DOWN, SEE FIGURE 12.....	1
3	XCFFF	XCOOO		0AK42	1B07	. PISTON & ROD BREAKDOWN, SEE FIGURE 14.....	1
4	XCFFF	XCFFF		0AK42	1B11	. FUEL INJECTION PUMP BREAK-DOWN, SEE FIGURE 17.....	1
5	XCFFF	XCFFF		0AK42	1A10	. LUBE OIL PUMP & GOV. BREAK-DOWN, SEE FIGURE 15.....	1
6	XCFFF	XCFFF		0AK42	1B06	. CAM/CRANK/BALANCER BREAK-DOWN, SEE FIGURE 13.....	1
7	XCFFF	XCFFF		0AK42	1B04	. CYLINDER HEAD & COV. BREAK-DOWN, SEE FIGURE 11.....	1
8	XCFFF	XCFFF		0AK42	1B15	. STARTING MOTOR & DYNAMO BREAKDOWN, SEE FIGURE 18.....	1
9	XCFFF	XCFFF		0AK42	1A11	. COOLING & STARTING BREAK-DOWN, SEE FIGURE 16.....	1

END OF FIGURE

OPERATOR AND FIELD MAINTENANCE
2 kW MEP-501A/531A MILITARY TACTICAL GENERATOR SETS
GROUP 03010101 CYLINDER BLOCK INSTALLATION

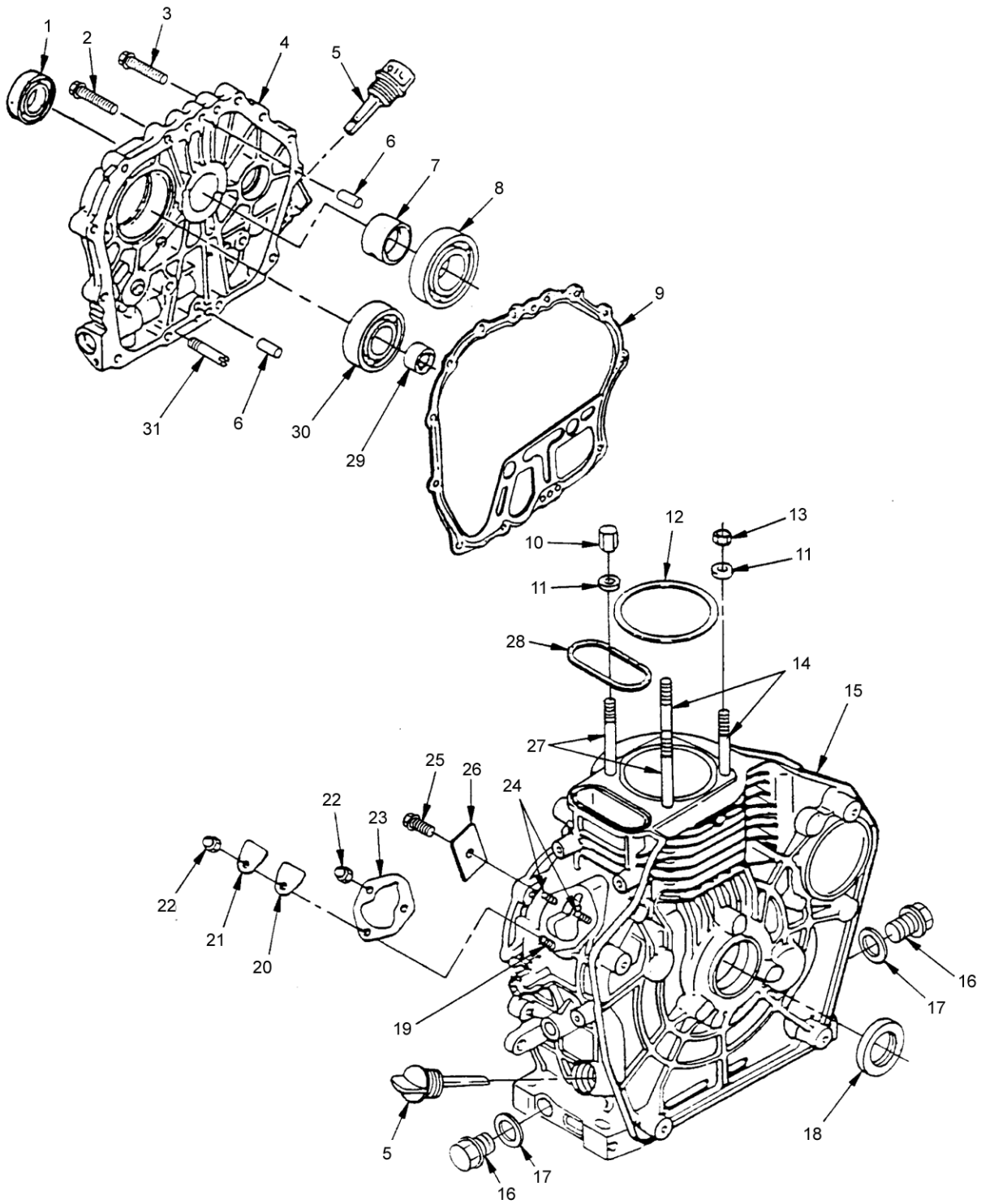

Figure 10. Cylinder Block Installation.

(1)	(2)		(3)	(4)	(5)	(6)	(7)
ITEM NO	SMR CODE		NSN	CAGEC	PART NUMBER	DESCRIPTION AND USABLE ON CODE (UOC)	QTY
	a. ARMY	b. AIR FORCE					
GROUP 03010101 CYLINDER BLOCK INSTALLATION							
FIG. 10 CYLINDER BLOCK INSTALLATION							
1	PAFZZ	PAFZZ	5330-01-324-8253	OAK42	160210-02220	. SEAL, PLAIN ENCASED	1
2	PAFZZ	PAFZZ	5305-01-255-6548	62866	10512	. SCREW, CAP, HEXAGON	14
3	PAFZZ	PAFZZ		OAK42	26106-080352	. BOLT, MACHINE	1
4	XBFZZ	XBOZZ		OAK42	114260-01453	. COVER, CRANKCASE	1
5	PAFZZ	PAOZZ	5342-01-359-6858	OAK42	160710-01760	. CAP, FILLER OPENING	2
6	PAFZZ	PAFZZ		OAK42	22312-080120	. PIN, STRAIGHT, HEAD	2
7	XBFZZ	XBFZZ	3120-01-324-5762	OAK42	114250-02210	. BEARING, MAIN 0.50	1
7	XBFZZ	XBFZZ		OAK42	114250-02200	. BEARING, MAIN 0.25	1
7	PAFZZ	PAFZZ		OAK42	114250-02100	. BEARING, SLEEVE	1
8	PAFZZ	PAFZZ	3110-01-354-3572	OAK42	114250-02113	. BALL, BEARING	1
9	PAFZZ	PAFZZ	5330-01-353-6007	OGUY0	114250-01412	. GASKET	1
10	PAFZZ	PAFZZ		OAK42	114250-01220	. NUT, PLAIN, HEXAGON	2
11	PAFZZ	PAFZZ		OAK42	124950-01250	. WASHER	4
12	PAFZZ	PAFZZ		OAK42	114770-01340	. O-RING	1
13	PAFZZ	PAFZZ		OAK42	114250-01250	. NUT, PLAIN, HEXAGON	2
14	XBFZZ	XBFZZ		OAK42	114250-01210	. STUD, CYLINDER HEAD	2
15	XBFZZ	XBFZZ		OAK42	714771-01560	. BLOCK ASSY, CYLINDER	1
16	PAFZZ	PAOZZ	4730-01-322-4956	OAK42	105425-01690	. PLUG, M16	2
17	PAFZZ	PAOZZ	5330-01-326-2669	OAK42	22190-160002	. GASKET	4
18	PAFZZ	PAFZZ	5330-01-324-8254	OAK42	160110-02220	. SEAL, PLAIN ENCASED	1
19	XBFZZ	XBFZZ		OAK42	26226-060182	. STUD, M6X18 PLATE	1
20	PAFZZ	PAFZZ	5330-01-328-4171	OAK42	114250-01841	. GASKET	1
21	PAFZZ	PAFZZ	5340-01-415-3789	OAK42	114250-01830	. COVER, ACCESS	1
22	PAFZZ	PAFZZ	5310-01-388-8826	OAK42	26366-060002	. NUT, PLAIN, HEXAGON	3
23	PAFZZ	PAFZZ	5365-01-415-6744	OAK42	114250-01800	. SHIMSET	1
24	XBFZZ	XBFZZ		OAK42	26226-060222	. STUD, M6X22 PLATE	2
25	XBFZZ	XBFZZ		OAK42	26106-080122	. BOLT, M8X12 PLATE	1
26	PAFZZ	PAFZZ	3110-01-417-1057	OAK42	114250-02030	. PLATE, RETAINING	1
27	XBFZZ	XBFZZ		OAK42	114250-01200	. STUD, CYLINDER HEAD	2
28	PAFZZ	PAFZZ	5331-01-328-4148	OGUY0	114250-01380	. O-RING	1
29	PAFZZ	PAFZZ	3110-01-324-8817	OAK42	24162-152112	. BEARING, ROLLER	1
30	PAFZZ	PAFZZ	3110-01-324-8815	OAK42	24101-062050	. BEARING, BALL	1
31	XBFZZ	XBFZZ		OAK42	114250-35150	. PIPE, L.O. INLET	1

END OF FIGURE

OPERATOR AND FIELD MAINTENANCE
2 kW MEP-501A/531A MILITARY TACTICAL GENERATOR SETS
GROUP 03010102 CYLINDER HEAD INSTALLATION

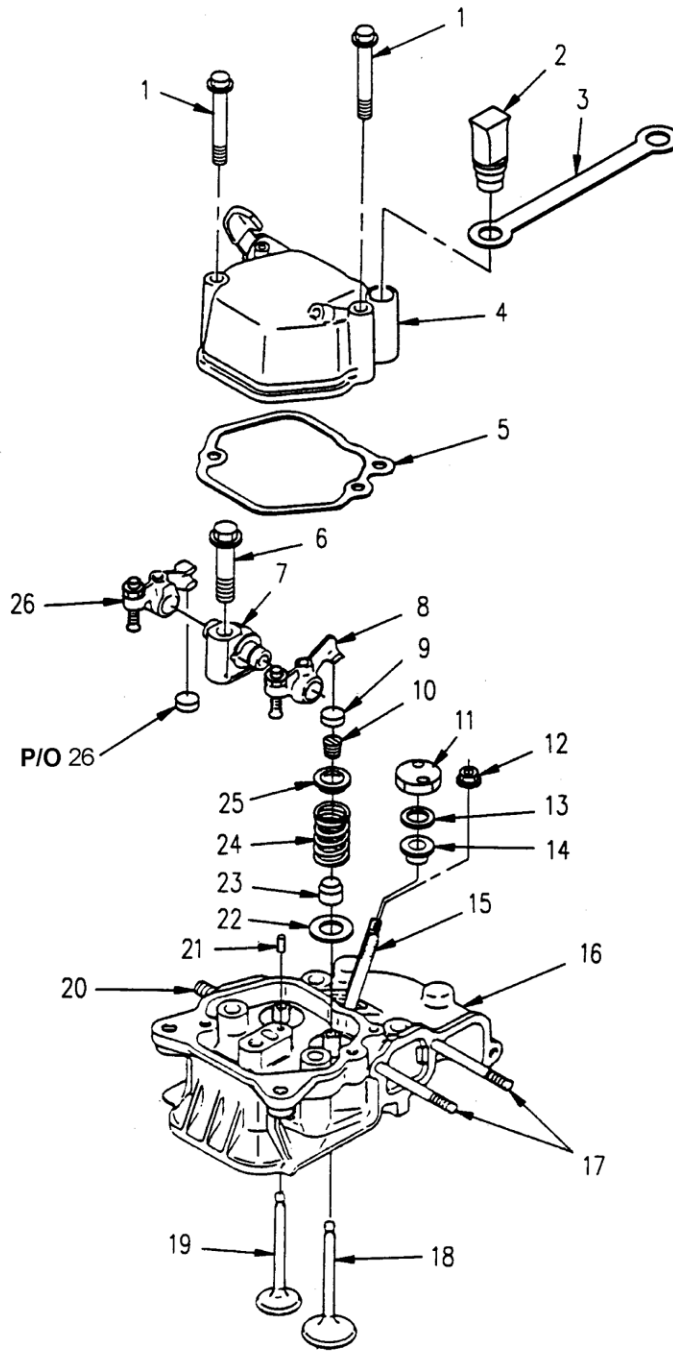

Figure 11. Cylinder Head Installation.

(1)	(2)		(3)	(4)	(5)	(6)	(7)
ITEM NO	SMR CODE		NSN	CAGEC	PART NUMBER	DESCRIPTION AND USABLE ON CODE (UOC)	QTY
	a. ARMY	b. AIR FORCE					

GROUP 03010102 CYLINDER HEAD INSTALLATION

FIG. 11 CYLINDER HEAD INSTALLATION

1	PAFZZ	PAOZZ	5306-01-323-5440	0AK42	26106-060552	. BOLT, MACHINE	2
2	PAFZZ	PAOZZ		0AK42	114250-76600	. PLUNGER, DETENT	1
3	XBFZZ	XBOZZ		0AK42	114250-76610	. PLUNGER, QUICK RELEASE	1
4	PAFZZ	PAOZZ	2815-01-324-6802	0AK42	114250-11951	. BONNET ASSEMBLY, HEAD	1
5	PAFZZ	PAOZZ	5330-01-326-8022	0AK42	114250-11310	. GASKET	1
6	XBFZZ	XBFZZ	5306-01-388-6230	0AK42	26106-080452	. BOLT, MACHINE	1
7	XBFZZ	XBFZZ		0AK42	114250-11290	. SUPPORT, ROCKER ARM	1
8	XBFZZ	XBFZZ		0AK42	114250-11651	. CRANK, HAND	1
9	PAFZZ	PAFZZ	2815-01-393-9880	0AK42	119260-11370	. INSERT, ENGINE VALVE	1
10	PAFZZ	PAFZZ	2815-01-323-1352	0AK42	714250-11570	. LOCK, VALVE SPRING	2
11	PAFZZ	PAOZZ	2815-01-324-6801	0AK42	114250-11900	. RETAINER, DIESEL ENG.	1
12	PAFZZ	PAOZZ	5310-01-388-8826	0AK42	26366-060002	. NUT, PLAIN, HEXAGON	2
13	PAFZZ	PAOZZ	5365-01-322-8692	0AK42	114350-11470	. SPACER, SLEEVE	1
14	PAFZZ	PAOZZ	5330-01-326-8021	0AK42	114250-11460	. GASKET	1
15	PAFZZ	PAFZZ	5307-01-323-5503	0AK42	26226-060502	. STUD, PLAIN	2
16	XBBZZ	XBBZZ	2815-01-319-3174	0GUY0	114250-11020	. CYLINDER HEAD, DIESEL	1
17	PAFZZ	PAFZZ	5307-01-323-5504	0AK42	26226-060552	. STUD, PLAIN	2
18	PAFZZ	PAFZZ	2815-01-323-1290	0AK42	114250-11101	. VALVE, POPPET, ENGINE	1
19	PAFZZ	PAFZZ	2815-01-323-1291	0AK42	114250-11113	. VALVE, POPPET, ENGINE	1
20	PAFZZ	PAFZZ		0AK42	26216-080182	. STUD, PLAIN	2
21	PAFZZ	PAFZZ		0AK42	22351-040008	. PIN, SPRING	1
22	PAFZZ	PAFZZ		0AK42	114250-11600	. WASHER, FLAT	2
23	PAFZZ	PAFZZ	5331-01-324-8831	0AK42	114250-11340	. O-RING	2
24	PAFZZ	PAFZZ	5360-01-324-3995	0AK42	114250-11120	. SPRING, HELICAL	2
25	PAFZZ	PAFZZ	5340-01-324-8850	0AK42	114250-11180	. SEAT, HELICAL COMPR.	2
26	XBFZZ	XBFZZ		0AK42	714270-11660	. ARM ASSEMBLY, EXHAUST	1

END OF FIGURE

OPERATOR AND FIELD MAINTENANCE
2 kW MEP-501A/531A MILITARY TACTICAL GENERATOR SETS
GROUP 03010103 AIR INTAKE PIPE AND MUFFLER

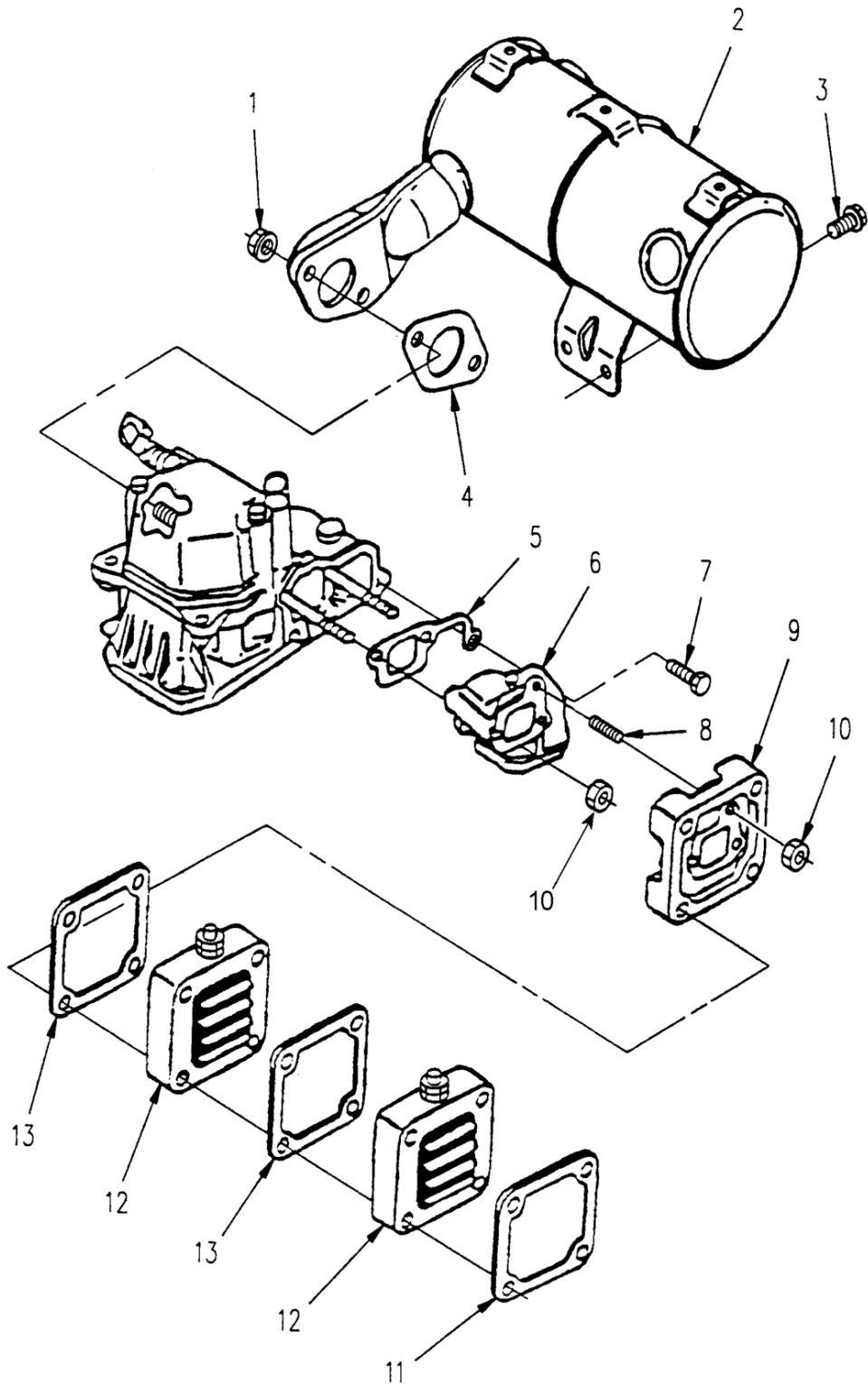

Figure 12. Air Intake Pipe and Muffler.

(1)	(2)		(3)	(4)	(5)	(6)	(7)
ITEM NO	SMR CODE		NSN	CAGEC	PART NUMBER	DESCRIPTION AND USABLE ON CODE (UOC)	QTY
	a. ARMY	b. AIR FORCE					

GROUP 03010103 AIR INTAKE PIPE AND MUFFLER

FIG. 12 AIR INTAKE PIPE AND MUFFLER

1	PAFZZ	PAOZZ	5310-01-322-8607	0AK42	26366-080002	. NUT, PLAIN, HEXAGON	2
2	PAFZZ	PAOZZ		0AK42	114268-13510	. MUFFLER, EXHAUST	1
3	PAFZZ	PAOZZ	5305-01-300-6264	80204	B18231B06012N	. SCREW, CAP, HEX	2
4	PAFZZ	PAOZZ	5330-01-326-4780	0AK42	114250-13200	. GASKET	1
5	PAFZZ	PAOZZ	5330-01-324-8287	0AK42	114250-12200	. GASKET	1
6	XBFZZ	XBOZZ		0AK42	114250-12010	. PIPE, AIR INTAKE	1
7	PAFZZ	PAOZZ	5305-01-255-6548	62866	10512	. SCREW, CAP, HEX	1
8	PAFZZ	PAOZZ	5307-01-323-5505	0AK42	26226-060142	. STUD, PLAIN	1
9	XBFZZ	XBOZZ	5365-01-419-5477	0AK42	183375-77560	. SPACER, PLATE	1
10	PAFZZ	PAOZZ	5310-01-388-8826	0AK42	26366-060002	. NUT, PLAIN, HEXAGON	2
11	PAFZZ	PAOZZ	5330-01-326-4773	0AK42	114250-12210	. O-RING	1
12	PAFZZ	PAOZZ		0AK42	129400-77501	. HEATING ELEMENT	2
13	XBFZZ	XBOZZ		0AK42	129100-77510	. GASKET	2

END OF FIGURE

OPERATOR AND FIELD MAINTENANCE
2 KW MEP-501A/531A MILITARY TACTICAL GENERATOR SETS
GROUP 03010104 CAM/CRANKSHAFT/BALANCER INSTALLATION

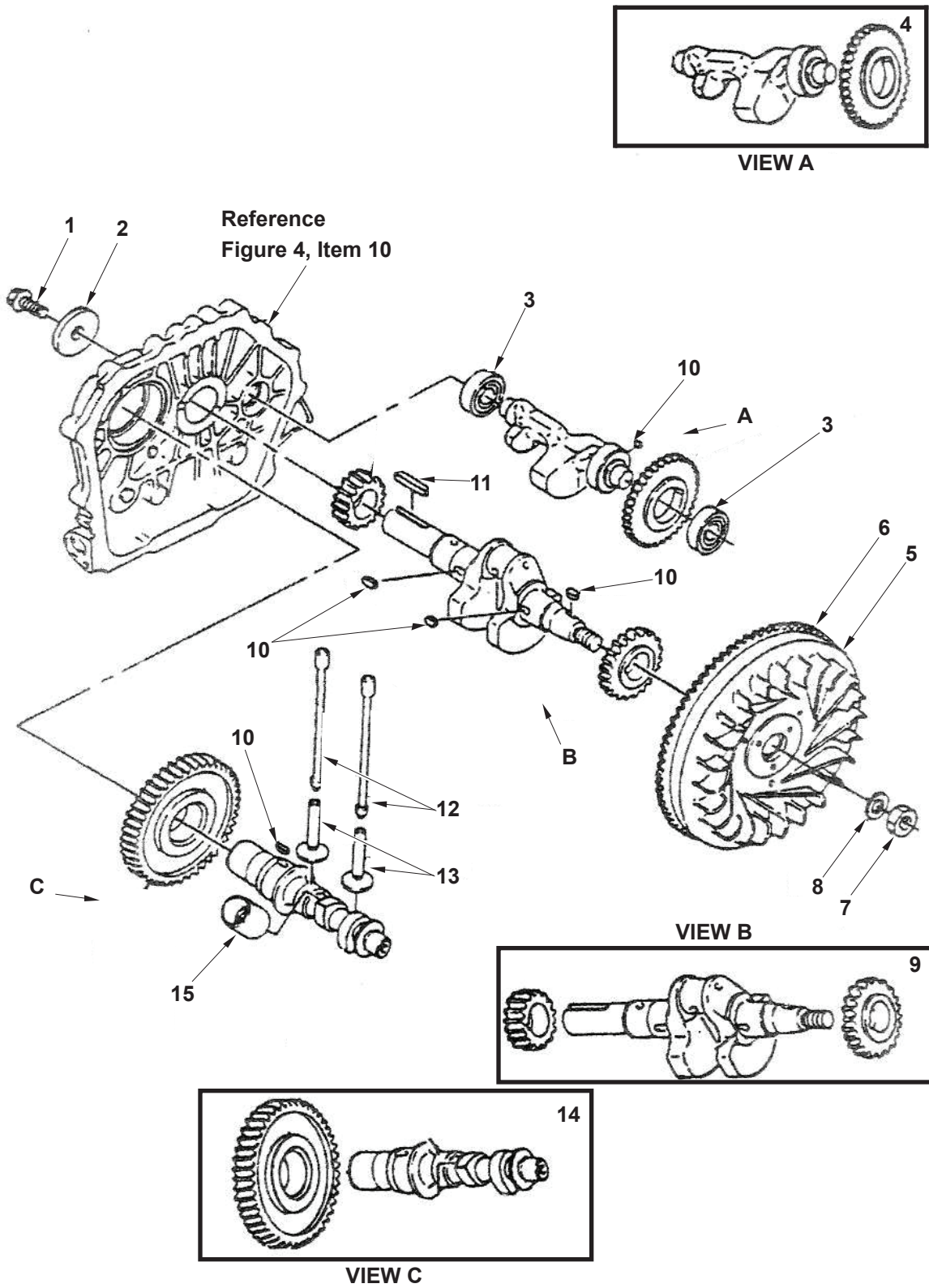

Figure 13 Cam/Crankshaft/Balancer Installation

(1)	(2)		(3)	(4)	(5)	(6)	(7)
ITEM NO	SMR CODE		NSN	CAGEC	PART NUMBER	DESCRIPTION AND USABLE ON CODE (UOC)	QTY
	a. ARMY	b. AIR FORCE					

**GROUP 03010104
CAM/CRANKSHAFT/BALANCER
INSTALLATION**

**FIG. 13
CAM/CRANKSHAFT/BALANCER
INSTALLATION**

1	PAFZZ	PAFZZ		0AK42	160642-21250	. BOLT, MACHINE	1
2	XBFZZ	XBFZZ		0AK42	160310-14550	. WASHER	1
3	PAFZZ	PAFZZ	3110-01-322-9532	0AK42	24101-062024	. BEARING, BALL	2
4	XBFZZ	XBFZZ		0AK42	714770-28510	. SHAFT ASSEMBLY	1
5	XBFFF	XBFFF		0AK42	114781-21590	. FLYWHEEL, W/GEAR	1
6	XBFZZ	XBFZZ		0AK42	114262-21600	. GEAR, RING	1
7	PAFZZ	PAFZZ	5310-01-398-0737	0AK42	103854-01221	. NUT, PLAIN, HEXAGON	1
8	PAFZZ	PAFZZ		0AK42	114250-21550	. WASHER, FLAT	1
9	XBFZZ	XBFZZ		0AK42	714288-21700	. CRANKSHAFT ASSY	1
10	PAFZZ	PAFZZ		0AK42	22512-040120	. KEY, MACHINE	1
11	PAFZZ	PAFZZ	5315-01-388-8937	0AK42	160642-21150	. KEY, MACHINE	1
12	PAFZZ	PAFZZ	2815-01-389-9590	0AK42	114250-14450	. PUSH ROD, ENGINE	2
13	PAFZZ	PAFZZ	2815-01-323-0352	0AK42	114250-14200	. TAPPET, ENGINE POPPET	2
14	XBFZZ	XBFZZ	2815-01-348-5888	0GUY0	714780-14580	. CAMSHAFT, ENGINE	1
15	PAFZZ	PAFZZ	2815-01-323-0353	0AK42	114250-14260	. TAPPET, ENGINE POPPET	1

END OF FIGURE

OPERATOR AND FIELD MAINTENANCE
2 kW MEP-501A/531A MILITARY TACTICAL GENERATOR SETS
GROUP 03010105 PISTON AND ROD ASSEMBLY

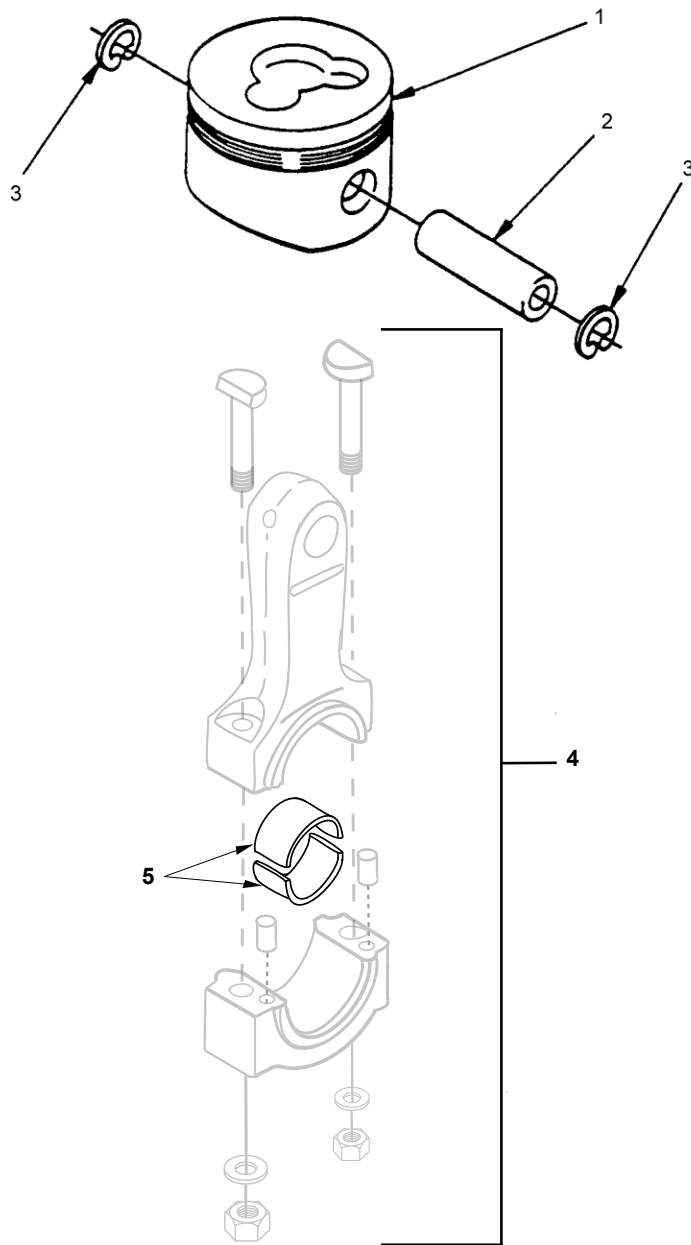

Figure 14. Piston and Rod Assembly.

(1)	(2)		(3)	(4)	(5)	(6)	(7)
ITEM NO	SMR CODE		NSN	CAGEC	PART NUMBER	DESCRIPTION AND USABLE ON CODE (UOC)	QTY
	a. ARMY	b. AIR FORCE					

GROUP 03010105 PISTON AND ROD ASSEMBLY

FIG. 14 PISTON AND ROD ASSEMBLY

1	XBFZZ	XBFZZ		0AK42	714780-22720	. PISTON W/RINGS	1
1	XBFZZ	XBFZZ		0AK42	714780-22620	. PISTON W/RING OS	1
1	XBFZZ	XBFZZ		0AK42	714780-22580	. PISTON W/RING OS	1
2	XBFZZ	XBFZZ	2815-01-323-0286	0AK42	114250-22302	. PIN, PISTON	1
3	XBFZZ	XBFZZ	5325-01-322-8679	0AK42	22252-000190	. RING, RETAINING	2
4	XBFZZ	XBFZZ		0AK42	714250-23703	. CONNECTING ROD, PIS	1
5	XBFZZ	XBFZZ	2815-01-323-0351	0AK42	714250-23620	. BEARING, PIN US=0.5	1
5	XBFZZ	XBFZZ	2815-01-323-0351	0AK42	714250-23610	. BEARING, PIN US=0.2	1

END OF FIGURE

OPERATOR AND FIELD MAINTENANCE
2 kW MEP-501A/531A MILITARY TACTICAL GENERATOR SETS
GROUP 03010106 LUBE OIL PUMP AND GOVERNOR

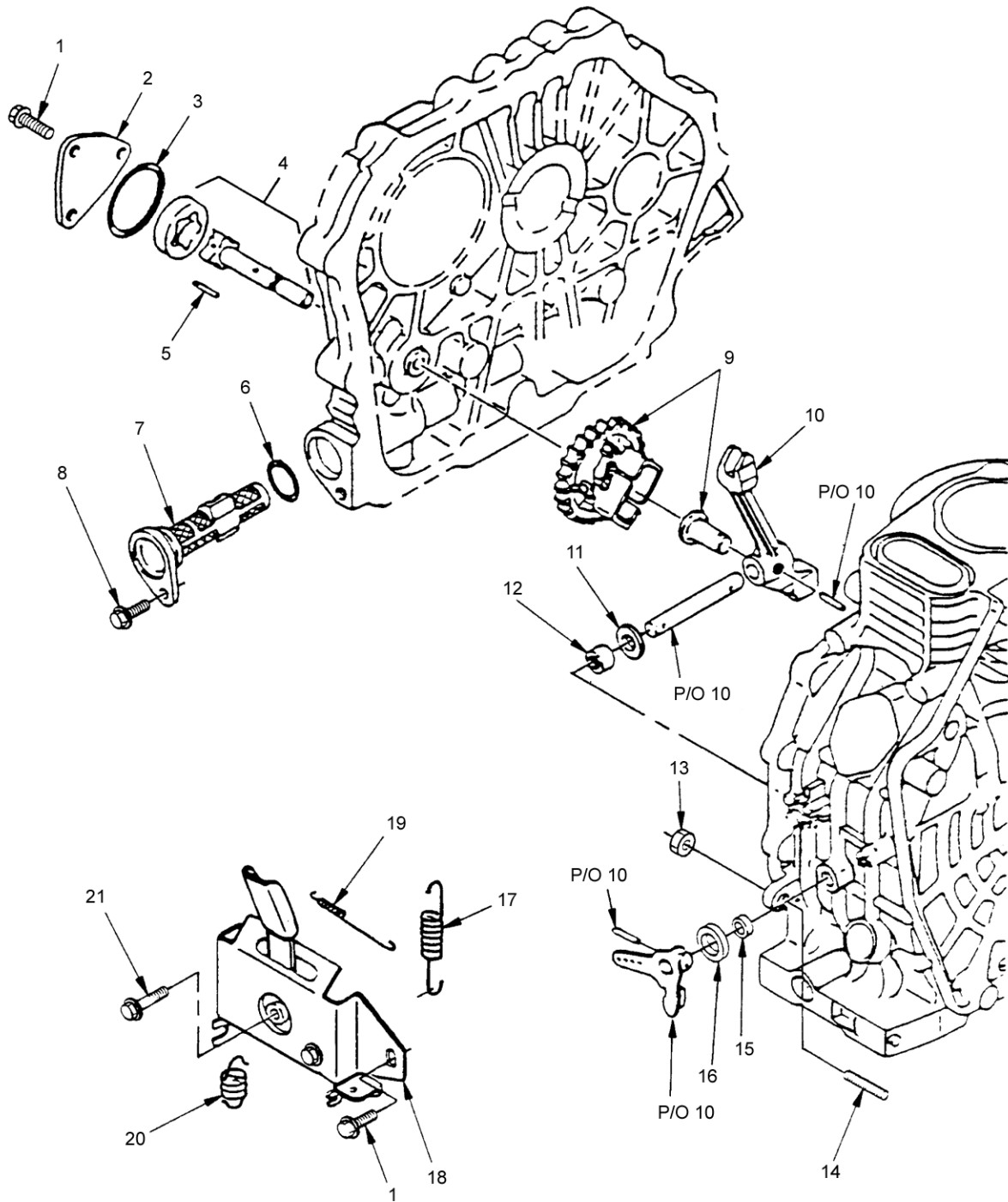

Figure 15. Lube Oil Pump and Governor.

(1)	(2)		(3)	(4)	(5)	(6)	(7)
	SMR CODE						
	a.	b.					
ITEM NO	ARMY	AIR FORCE	NSN	CAGEC	PART NUMBER	DESCRIPTION AND USABLE ON CODE (UOC)	QTY

GROUP 03010106 LUBE OIL PUMP AND GOVERNOR

FIG. 15 LUBE OIL PUMP AND GOVERNOR

1	PAFZZ	PAFZZ	5306-01-388-7402	OAK42	26476-060142	. BOLT, MACHINE	4
2	XBFZZ	XBFZZ	5340-01-433-5457	OAK42	114250-32070	. COVER, ACCESS	1
3	PAFZZ	PAFZZ	5331-01-324-8279	OAK42	103338-32570	. O-RING	1
4	PAFZZ	PAFZZ	4320-01-323-0298	OAK42	114250-32010	. PUMP, ROTARY	1
5	PAFZZ	PAFZZ	5315-01-431-8229	OAK42	22312-030160	. PIN, STRAIGHT, HEAD	1
6	PAFZZ	PAOZZ	5331-01-326-8017	OAK42	24341-000224	. O-RING	1
7	PAFZZ	PAOZZ	2815-01-353-7523	OGUY0	114250-35070	. STRAINER, OIL PUMP	1
8	PAFZZ	PAOZZ	5305-01-388-6229	OAK42	26106-060162	. SCREW, CAP, HEX	1
9	PAFZZ	PAFZZ	2990-01-353-7531	OGUY0	714770-61700	. GOVERNOR, DIESEL ENG.	1
10	PAFZZ	PAFZZ	3040-01-389-9592	OAK42	714250-61500	. LEVER, REMOTE CONTROL	1
11	PAFZZ	PAFZZ	5310-01-388-8825	OAK42	22137-080000	. WASHER, FLAT	1
12	PAFZZ	PAFZZ	3110-01-417-1465	OAK42	114270-61520	. BEARING, ROLLER	2
13	PAFZZ	PAOZZ	5310-01-431-4066	OAK42	26696-100002	. NUT, PLAIN, HEXAGON	1
14	PAFZZ	PAOZZ	5360-01-431-3108	OAK42	114250-66550	. SPRING, HELICAL	1
15	PAFZZ	PAFZZ	5330-01-415-3802	OAK42	114770-61600	. SEAL, PLAIN ENCASED	1
16	PAFZZ	PAFZZ	3010-01-389-9003	OAK42	114770-61610	. THRUST PLATE, TRANS.	1
17	PAFZZ	PAOZZ	5360-01-419-5483	OAK42	114770-66010	. SPRING, HELICAL	1
18	XBFFF	XBOOO		OAK42	183250-66511	. BRACKET, REGULATOR	1
19	PAFZZ	PAOZZ	5360-01-415-8733	OAK42	183250-66331	. SPRING, HELICAL	1
20	PAFZZ	PAOZZ	5360-01-322-8631	OAK42	114250-66200	. SPRING, HELICAL	1
21	PAFZZ	PAOZZ	5306-01-431-7457	OAK42	26106-060202	. BOLT, MACHINE	1

END OF FIGURE

OPERATOR AND FIELD MAINTENANCE
2 kW MEP-501A/531A MILITARY TACTICAL GENERATOR SETS
GROUP 03010107 COOLING/STARTING INSTALLATION

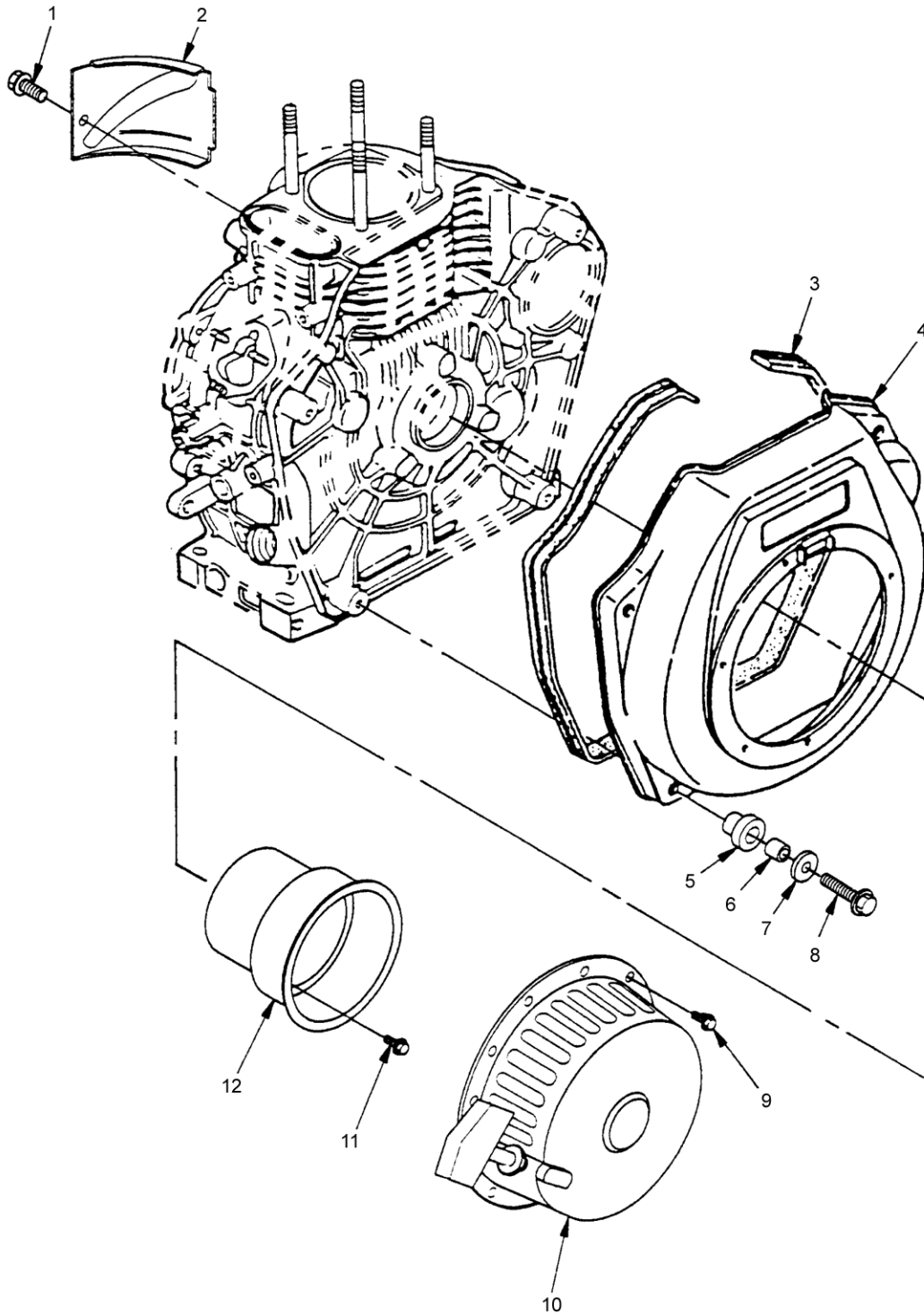

Figure 16. Cooling/Starting Installation.

(1)	(2)		(3)	(4)	(5)	(6)	(7)
	SMR CODE						
	a.	b.					
ITEM NO	ARMY	AIR FORCE	NSN	CAGEC	PART NUMBER	DESCRIPTION AND USABLE ON CODE (UOC)	QTY

**GROUP 03010107
COOLING/STARTING
INSTALLATION**

**FIG. 16 COOLING/STARTING
INSTALLATION**

1	PAFZZ	PAFZZ	5306-01-388-7402	0AK42	26476-060142	. BOLT, MACHINE	1
2	XBFZZ	XBFZZ	5340-01-389-1309	0AK42	114250-45211	. COVER, ACCESS	1
3	PAFZZ	PAFZZ	5330-01-330-9564	0AK42	114250-45330	. SEAL, PLAIN ENCASED	1
4	XBFZZ	XBFZZ	3020-01-322-5785	0AK42	114780-45100	. GUARD, MECHANICAL DR	1
5	PAFZZ	PAFZZ	2815-01-324-9200	0AK42	114250-45300	. RETAINER, ENGINE	4
6	PAFZZ	PAFZZ	5342-01-323-7866	0AK42	114250-45310	. COUPLING, CLAMP	4
7	PAFZZ	PAFZZ	5310-01-388-8806	0AK42	160120-76940	. WASHER, FLAT	4
8	PAFZZ	PAFZZ	5305-01-069-8235	61080	50025900	. SCREW, CAP, HEX	4
9	PAFZZ	PAOZZ	5305-01-163-5075	15526	933-M6X8	. SCREW, CAP, HEX	4
10	PAFZZ	PAOZZ	2990-01-323-0307	0AK42	714260-76821	. RECOIL STARTER ASSY	1
11	PAFZZ	PAFZZ	5305-01-300-6264	80204	B18231B06012N	. SCREW, CAP, HEX	3
12	XBFZZ	XBFZZ		0AK42	114250-76590	. PULLEY, STARTER	1

END OF FIGURE

OPERATOR AND FIELD MAINTENANCE
2 KW MEP-501A/531A MILITARY TACTICAL GENERATOR SETS
GROUP 03010108 FUEL INJECTION PUMP/INJECTOR INSTALLATION

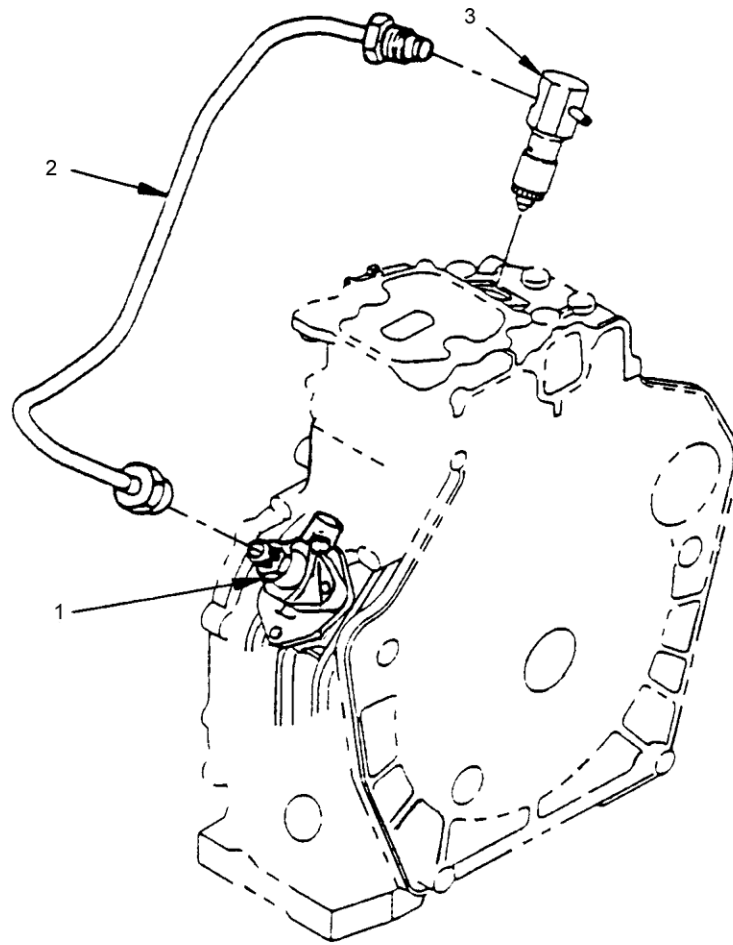

Figure 17. Fuel Injection Pump/Injector Installation.

(1)	(2)		(3)	(4)	(5)	(6)	(7)
ITEM NO	SMR CODE		NSN	CAGEC	PART NUMBER	DESCRIPTION AND USABLE ON CODE (UOC)	QTY
	a. ARMY	b. AIR FORCE					

GROUP 03010108 FUEL INJECTION PUMP/INJECTOR INSTALLATION

FIG. 17 FUEL INJECTION PUMP/INJECTOR INSTALLATION

1	PAFZZ	PAFZZ	2910-01-419-5484	0AK42	714770-51700	. INJECTION CONTROL	1
2	PAFZZ	PAFZZ	4710-01-425-8674	0AK42	114250-59800	. TUBE ASSEMBLY, METAL	1
3	PAFZZ	PAOZZ	2910-01-310-4522	0AK42	714250-53101	. PUMP, FUEL, METERING	1

END OF FIGURE

OPERATOR AND FIELD MAINTENANCE
2 KW MEP-501A/531A MILITARY TACTICAL GENERATOR SETS
GROUP 03010109 STARTING MOTOR AND DYNAMO INSTALLATION

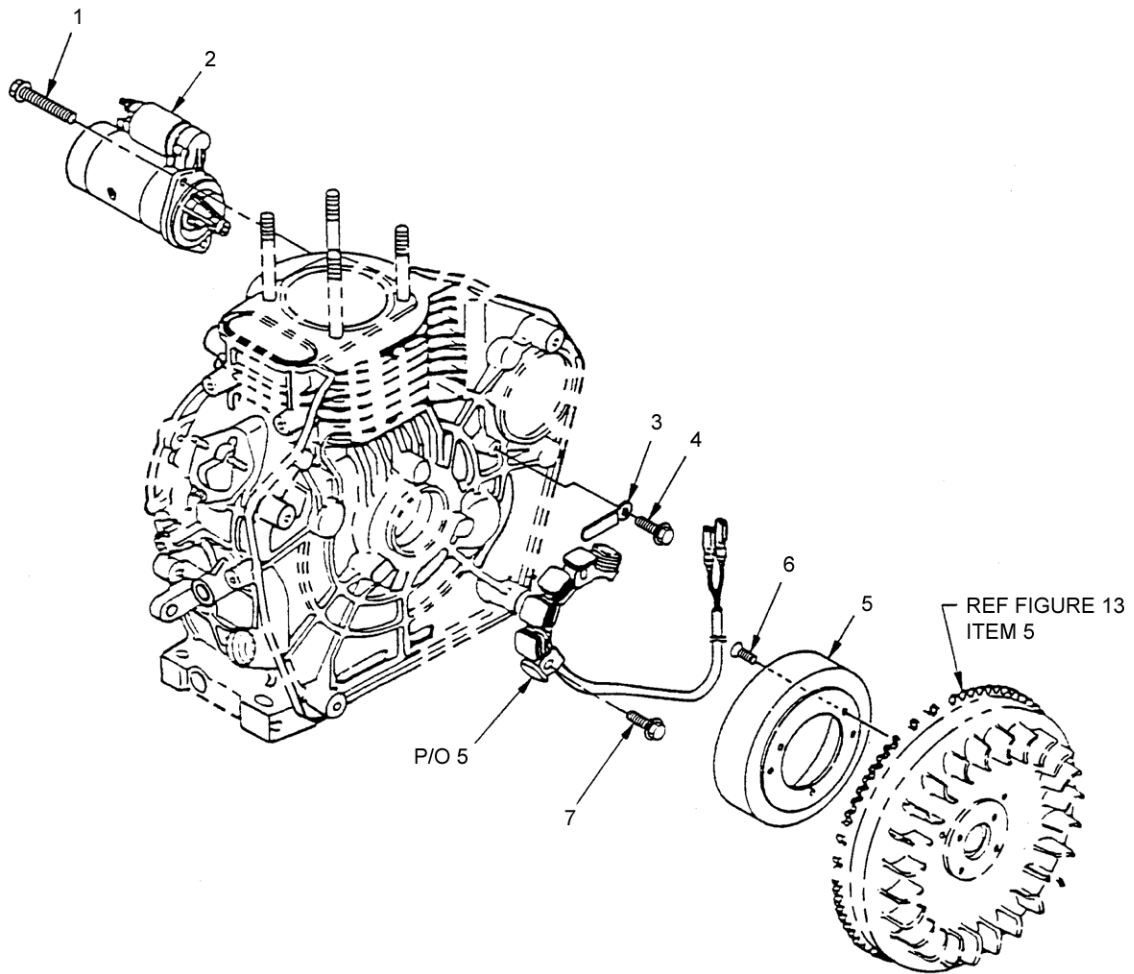

Figure 18. Starting Motor and Dynamo Installation.

(1)	(2)		(3)	(4)	(5)	(6)	(7)
ITEM NO	SMR CODE		NSN	CAGEC	PART NUMBER	DESCRIPTION AND USABLE ON CODE (UOC)	QTY
	a. ARMY	b. AIR FORCE					

GROUP 03010109 STARTING MOTOR AND DYNAMO INSTALLATION

FIG. 18 STARTING MOTOR AND DYNAMO INSTALLATION

1	PAFZZ	PAFZZ	5306-01-431-7460	0AK42	26106-100302	. BOLT, MACHINE	2
2	PAFZZ	PAFZZ	2920-01-452-8409	0AK42	114362-77019	. STARTER, ENGINE, ELEC.	1
3	XBFZZ	XBFZZ		0AK42	160710-78710	. CLAMP, CORD	1
4	XBFZZ	XBFZZ	5306-01-388-7402	0AK42	26476-060142	. BOLT, MACHINE	1
5	PAFZZ	PAFZZ	2920-01-419-5481	0AK42	114351-78260	. GENERATOR, ENGINE (DYNAMO)	1
6	XBFZZ	XBFZZ		0AK42	26577-060142	. SCREW, M6X14	3
7	XBFZZ	XBFZZ		0AK42	26476-060202	. BOLT	3

END OF FIGURE

OPERATOR AND FIELD MAINTENANCE
2 kW MEP-501A/531A MILITARY TACTICAL GENERATOR SETS
GROUP 0302 AC ALTERNATOR ASSEMBLY (MEP-531A)

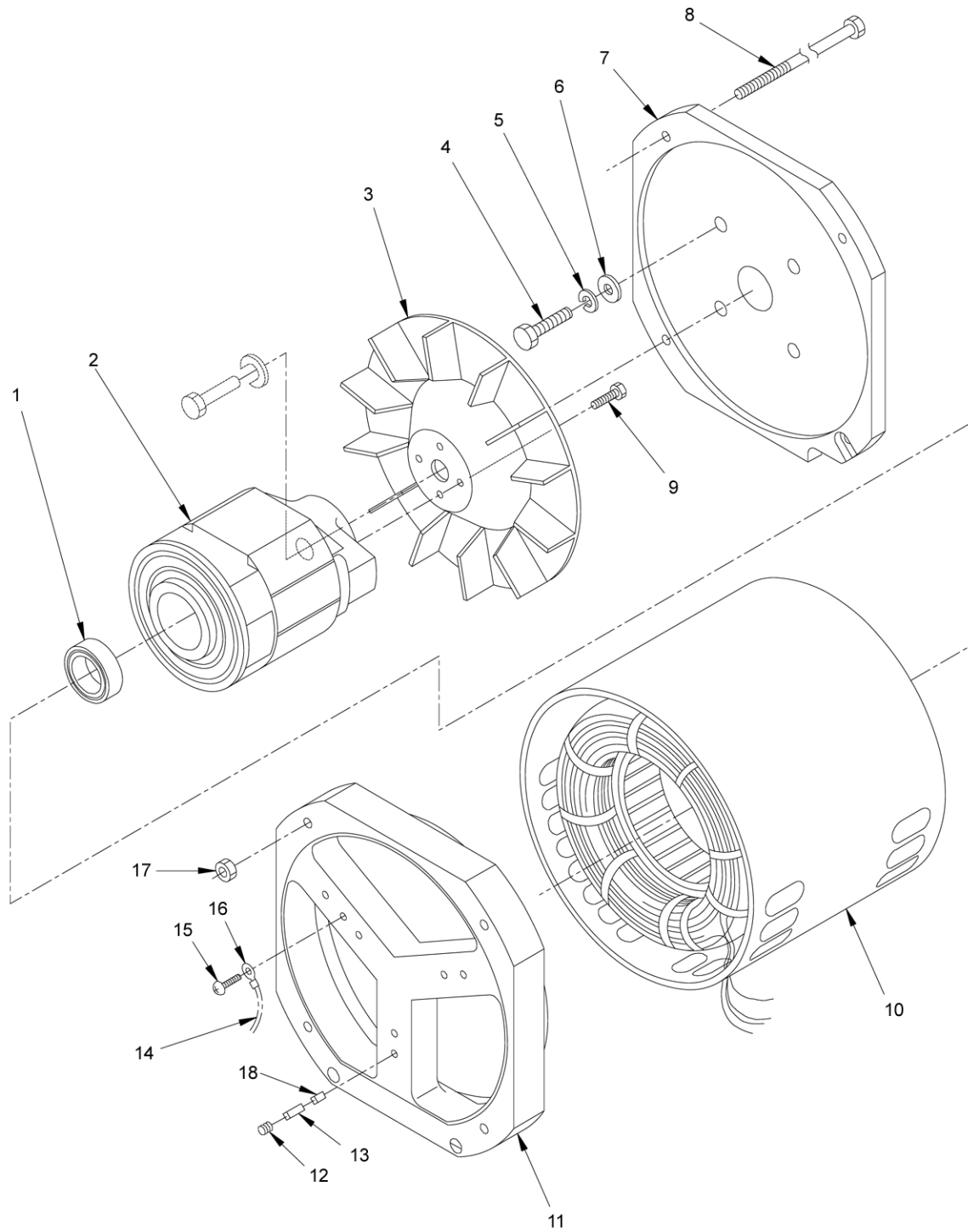

Figure 19. AC Alternator Assembly (MEP-531A).

(1)	(2)		(3)	(4)	(5)	(6)	(7)
ITEM NO	SMR CODE		NSN	CAGEC	PART NUMBER	DESCRIPTION AND USABLE ON CODE (UOC)	QTY
	a. ARMY	b. AIR FORCE					
GROUP 0302 AC ALTERNATOR ASSEMBLY (MEP-531A)							
FIG. 19 AC ALTERNATOR ASSEMBLY (MEP-531A)							
1	PAFZZ	PAFZZ	5940-01-467-8190	14058	31665	. BEARING	1
2	PAFZZ	PAFZZ	6115-01-419-3170	51879	65.00022	. ROTOR	1
3	PAFZZ	PAFZZ	6115-01-474-6268	51879	340.00000	. FAN	1
4	XBFZZ	XBFZZ		35537	608-370	. SCREW, CAP	4
5	XBFZZ	XBFZZ		35537	740-008	. WASHER, LOCK	4
6	XBFZZ	XBFZZ		35537	730-008	. WASHER, FLAT	4
7	XBFZZ	XBFZZ		14058	41432	. ADAPTER, ENGINE	1
8	PAFZZ	PAFZZ	5306-01-419-3173	51879	480.00020	. BOLT, STATOR	4
9	XBFZZ	XBFZZ	5305-00-983-7429	96906	MS16998-28	. SCREW, CAP, SOCKET HD	4
10	PAFZZ	PAFZZ	6115-01-472-5875	14058	41446-501	. STATOR ASSEMBLY	1
11	XBFZZ	XBFZZ		14058	41433	. BRACKET, BEARING	1
12	PAFZZ	PAOZZ	5999-01-210-6449	51879	660-00000	. CAP, BRUSH	4
13	PAFZZ	PAOZZ	5977-01-105-6201	51879	640-00000	. BRUSH	4
14	MFFZZ	MFFZZ		35537	D02134-4/5	. WIRE, 14AWG MAKE FROM M44A0111-14-0, WP 0153, BULK, ITEM 19, 6 INCHES REQUIRED	1
15	XBFZZ	XBOZZ		35537	D02134-6	. SCREW, 10-32	2
16	XBFZZ	XBOZZ		35537	P14-6RM	. RING, LUG	4
17	XBFZZ	XBFZZ		14058	31669	. NUT, KEPS	4
18	XBFZZ	XBFZZ		14058	31666	. HOLDER, BRUSH	4

END OF FIGURE

OPERATOR AND FIELD MAINTENANCE

2 kW MEP-501A/531A MILITARY TACTICAL GENERATOR SETS

GROUP 0303 DC ALTERNATOR ASSEMBLY (MEP-501A)

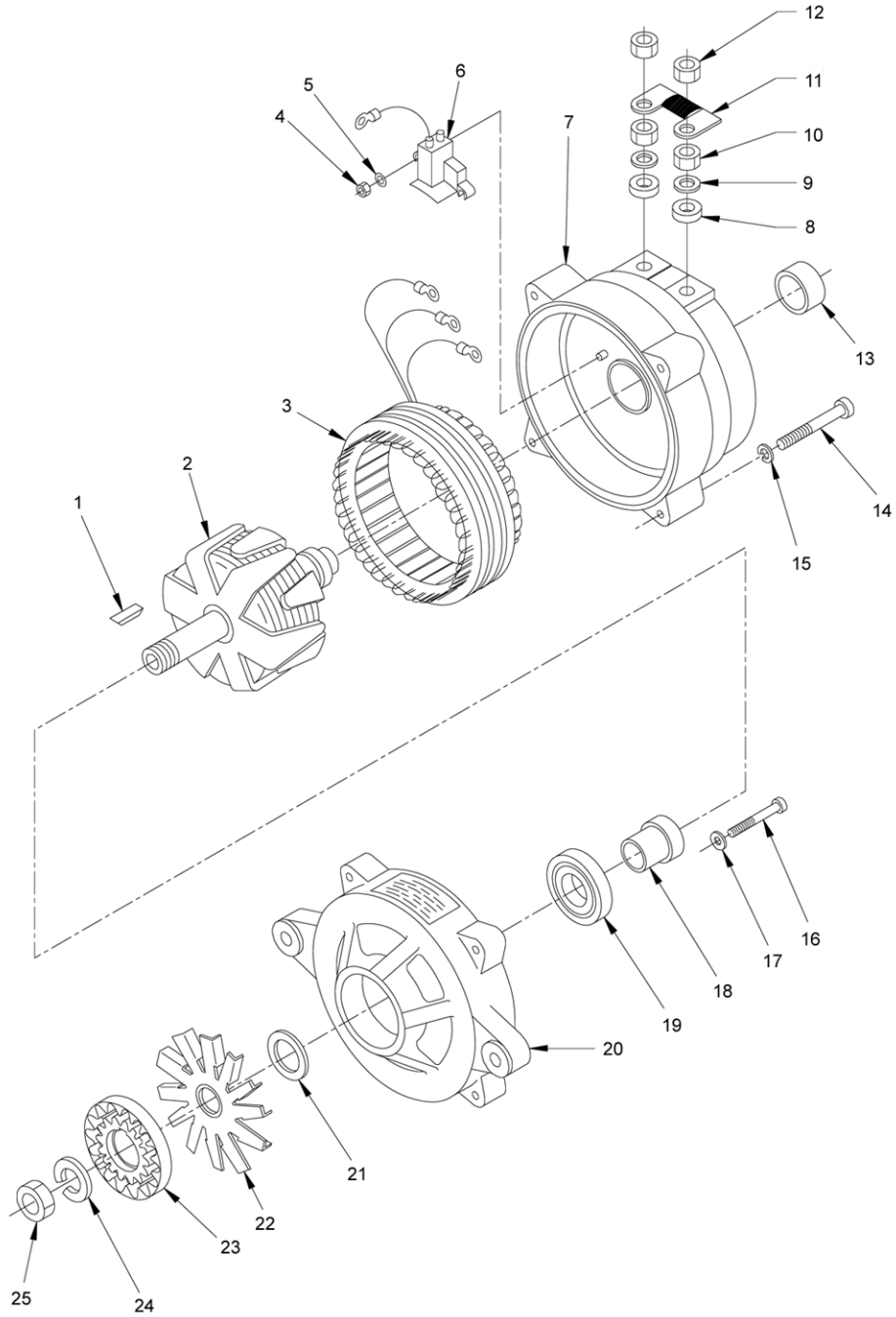

Figure 20. DC Alternator Assembly (MEP-501A) (Sheet 1 of 2).

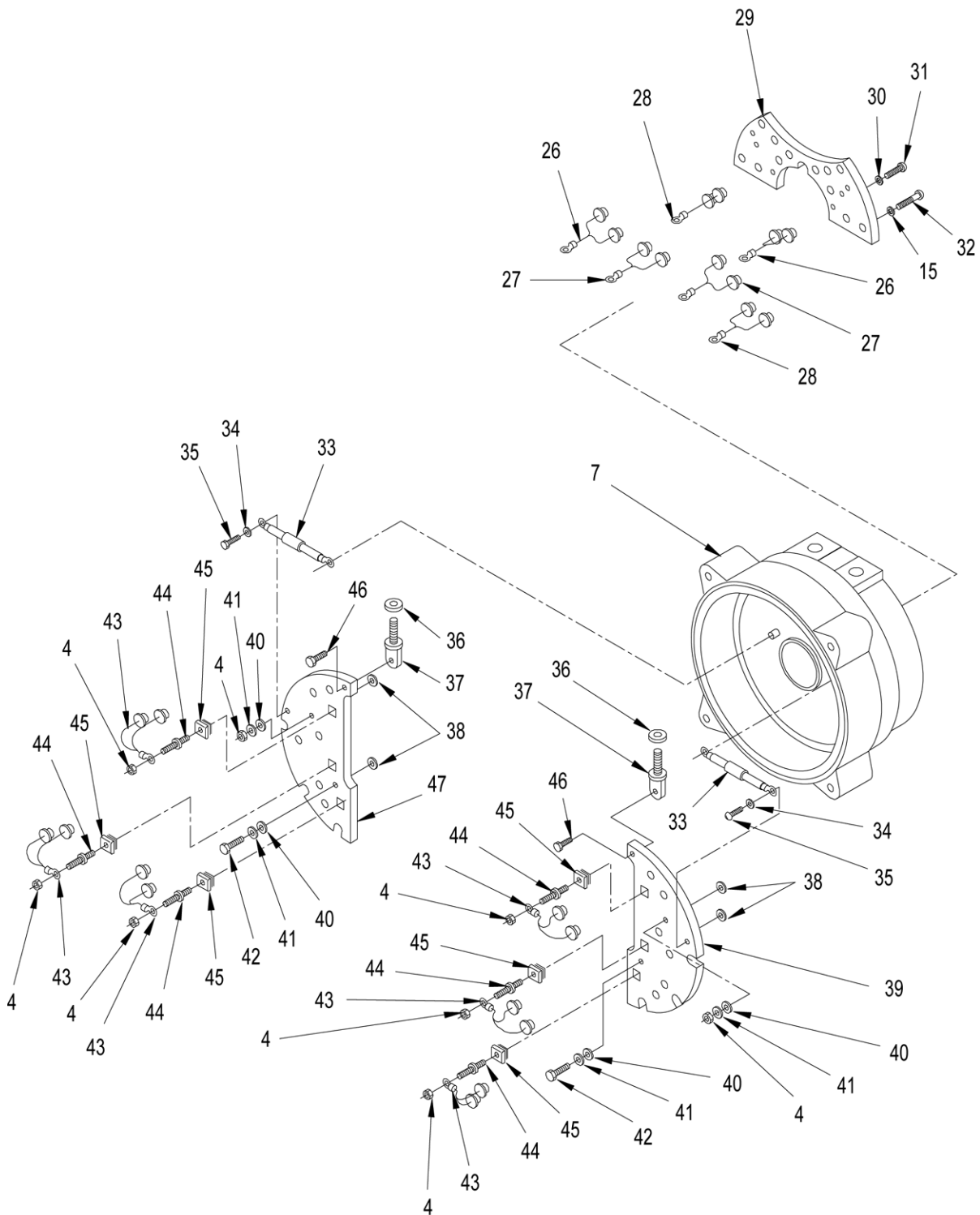

Figure 20. DC Alternator Assembly (MEP-501A) (Sheet 2 of 2).

(1)	(2)		(3)	(4)	(5)	(6)	(7)
ITEM NO	SMR CODE		NSN	CAGEC	PART NUMBER	DESCRIPTION AND USABLE ON CODE (UOC)	QTY
	a. ARMY	b. AIR FORCE					
GROUP 0303 DC ALTERNATOR ASSEMBLY (MEP-501A)							
FIG. 20 DC ALTERNATOR ASSEMBLY (MEP-501A)							
1	PAFZZ	PAFZZ	5315-01-419-3159	0L9X3	11-2710	. KEY	1
2	XBFZZ	XBFZZ	6115-01-419-3165	0L9X3	11-3010	. ROTOR, GENERATOR	1
3	XBFZZ	XBFZZ		0L9X3	11-2045	. STATOR, 45	1
4	XBFZZ	XBFZZ		0L9X3	11-1097	. NUT, KEPS	10
5	XBFZZ	XBFZZ		0L9X3	11-1081	. WASHER, FLAT	2
6	PAFZZ	PAFZZ	5977-01-426-1442	0L9X3	11-2712	. BRUSH HOLDER	1
7	XBFZZ	XBFZZ		0L9X3	11-2723	. HOUSING, REAR	1
8	XBFZZ	XBFZZ		0L9X3	11-1093	. INSULATOR	2
9	XBFZZ	XBFZZ		0L9X3	11-3308	. WASHER, FLAT	2
10	XBFZZ	XBFZZ		0L9X3	11-3309	. NUT, FLANGE	2
11	XBFZZ	XBFZZ		0L9X3	11-2709	. STRAP, BATTERY POST	1
12	XBFZZ	XBFZZ		0L9X3	11-3310	. NUT, LOCK, NYLON	2
13	PAFZZ	PAFZZ	3110-01-458-4163	0L9X3	11-1072-1	. BEARING, REAR	1
14	XBFZZ	XBFZZ		0L9X3	11-2701	. BOLT, THRU, ALLEN	4
15	XBFZZ	XBFZZ		0L9X3	11-2703	. WASHER, LOCK	5
16	XBFZZ	XBFZZ		0L9X3	11-3306	. SCREW, RETAINER	3
17	XBFZZ	XBFZZ		0L9X3	11-3302	. WASHER, RETAINER	3
18	PAFZZ	PAFZZ	3120-01-419-9010	0L9X3	11-3304	. BUSHING, ROTOR	1
19	PAFZZ	PAFZZ		0L9X3	11-3303-1	. BEARING, FRONT	1
20	XBFZZ	XBFZZ		0L9X3	11-3300	. HOUSING, FRONT	1
21	PAFZZ	PAFZZ	5975-01-461-2989	0L9X3	11-3305	. BUSHING	1
22	PAFZZ	PAFZZ	6115-01-419-3166	0L9X3	11-3301	. FAN	1
23	XBFZZ	XBFZZ	3010-01-419-3164	0L9X3	20-271-17MM	. PULLEY, GEAR DRIVE	1
24	XBFZZ	XBFZZ		0L9X3	11-1025	. WASHER, LOCK	1
25	XBFZZ	XBFZZ	5310-01-419-3175	0L9X3	11-1030	. NUT	1
26	XBFZZ	XBFZZ	5961-01-450-6429	0L9X3	11-5531	. SEMICONDUCTOR DEVICE	2
27	XBFZZ	XBFZZ	5961-01-420-0966	0L9X3	11-5531-2	. DIODE ASSEMBLY, 3-3	2
28	XBFZZ	XBFZZ	5961-01-425-0277	0L9X3	11-5531-1	. DIODE ASSEMBLY, 2-1	2
29	XBFZZ	XBFZZ		0L9X3	10-2718	. HEATSINK, NEGATIVE	1
30	XBFZZ	XBFZZ		0L9X3	11-2717-3	. SPACERS	4
31	XBFZZ	XBFZZ		0L9X3	11-2713	. SCREW, CAP	4
32	XBFZZ	XBFZZ		0L9X3	11-2707	. BOLT, HEX	1
33	XBFZZ	XBFZZ		0L9X3	11-1503	. CAPACITOR	2
34	XBFZZ	XBFZZ		0L9X3	11-1070	. WASHER, LOCK	2
35	XBFZZ	XBFZZ		0L9X3	11-1099	. SCREW	2
36	XBFZZ	XBFZZ		0L9X3	11-1094	. WASHER, FIBER	2
37	XBFZZ	XBFZZ		0L9X3	11-1113	. POST, BATTERY	2
38	XBFZZ	XBFZZ		0L9X3	11-2745	. INSULATOR	4
39	XBFZZ	XBFZZ		0L9X3	11-2715-1	. HEATSINK, LEFT POS.	1
40	XBFZZ	XBFZZ		0L9X3	11-1083	. INSULATOR	4
41	XBFZZ	XBFZZ		0L9X3	11-2708	. WASHER, FLAT	4
42	XBFZZ	XBFZZ		0L9X3	11-1109	. SCREW	2
43	XBFZZ	XBFZZ		0L9X3	11-8303	. DIODE ASSEMBLY, DUAL	6
44	XBFZZ	XBFZZ		0L9X3	11-1080	. TERMINAL, HEATSINK	6

(1)	(2)		(3)	(4)	(5)	(6)	(7)
SMR CODE							
a.		b.					
ITEM NO	ARMY	AIR FORCE	NSN	CAGEC	PART NUMBER	DESCRIPTION AND USABLE ON CODE (UOC)	QTY
45	XBFZZ	XBFZZ		0L9X3	11-1079	. INSULATOR, HEATSINK	6
46	XBFZZ	XBFZZ		0L9X3	11-1098	. BOLT, FLANGE	2
47	XBFZZ	XBFZZ		0L9X3	11-2714-1	. HEATSINK, RIGHT POS.	1

END OF FIGURE

OPERATOR AND FIELD MAINTENANCE
2 kW MEP-501A/531A MILITARY TACTICAL GENERATOR SETS
GROUP 04 CONTROL PANEL ASSEMBLY (MEP-531A)

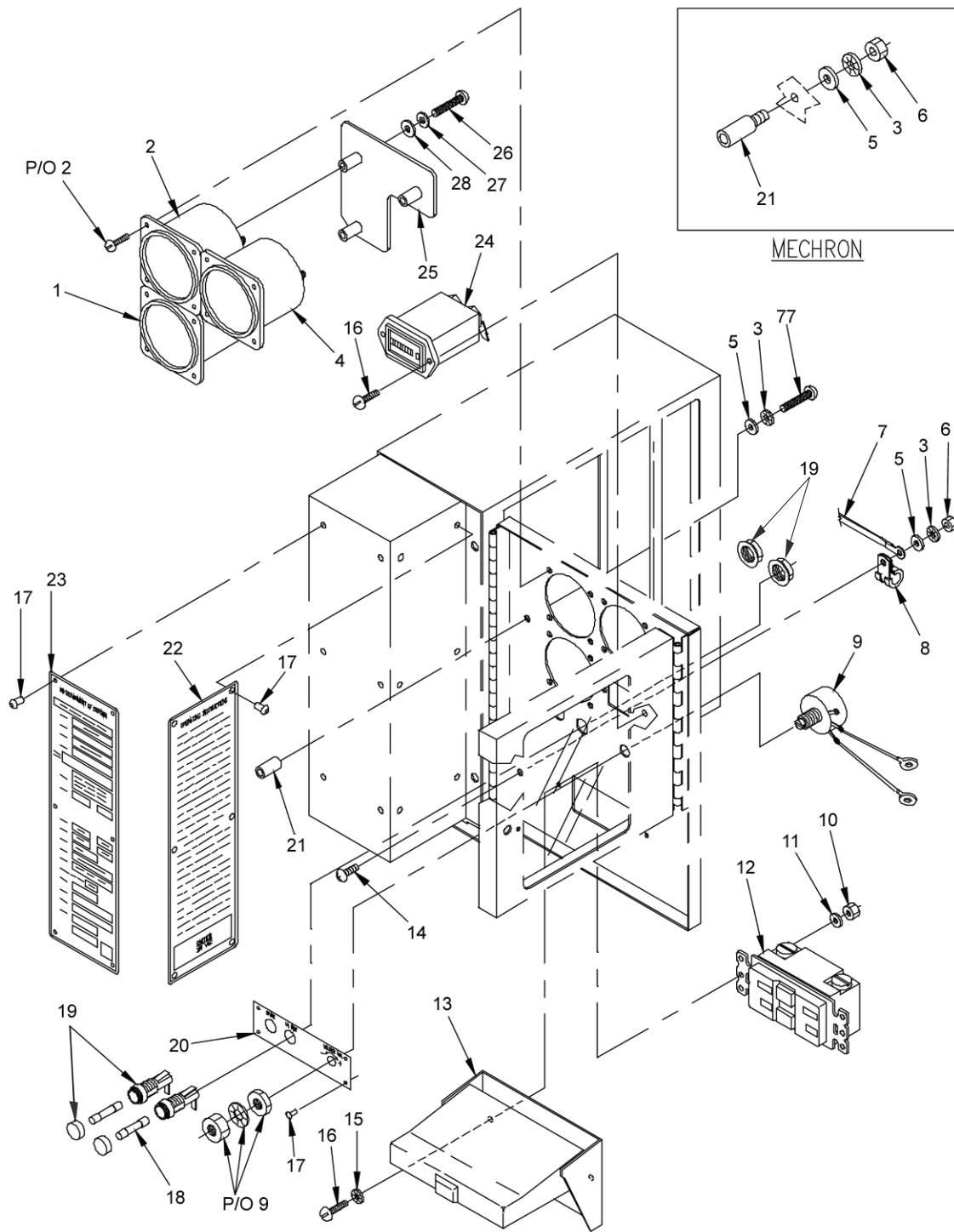

Figure 21. Control Panel Assembly (MEP-531A) (Sheet 1 of 3).

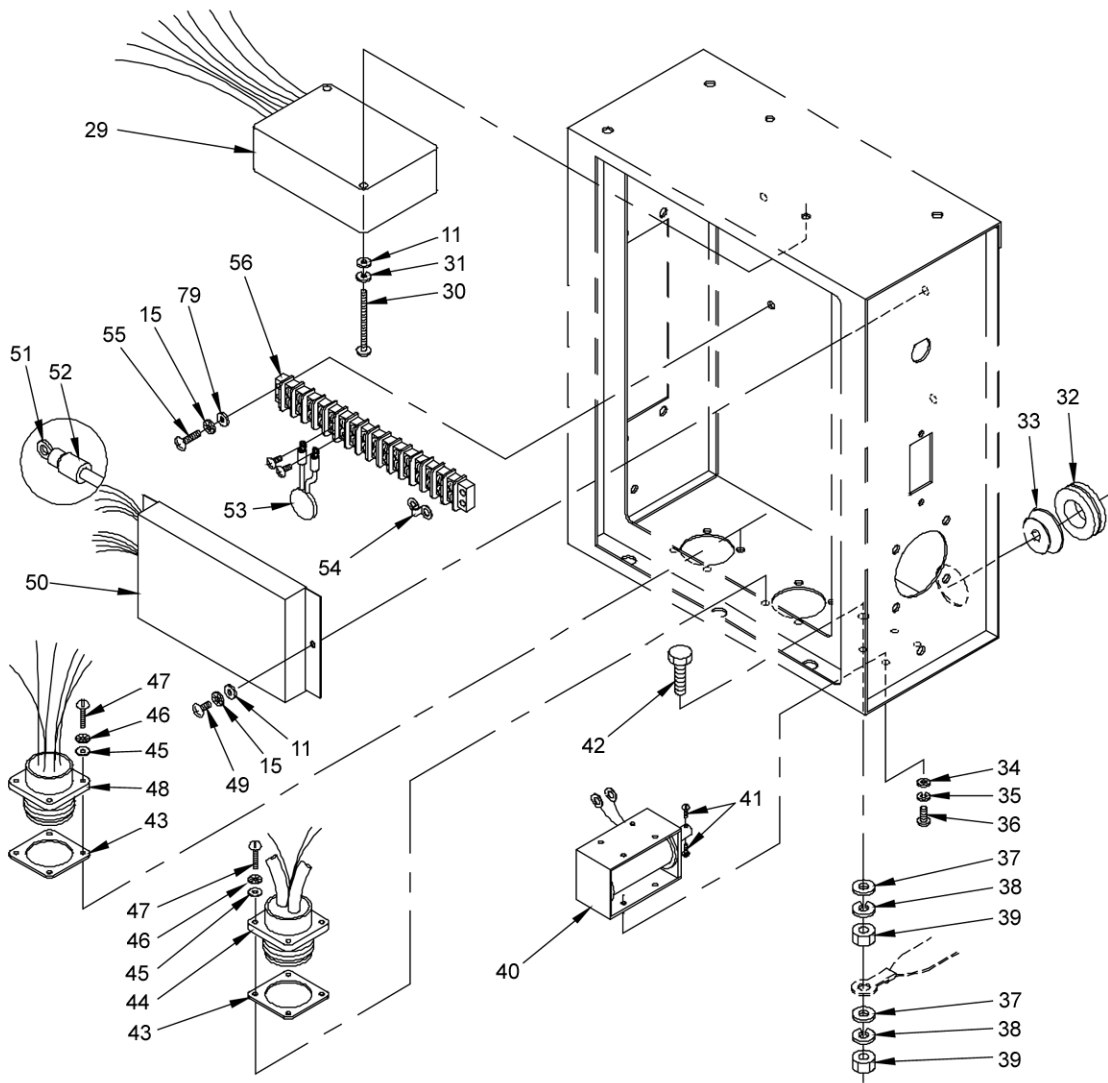

Figure 21. Control Panel Assembly (MEP-531A) (Sheet 2 of 3).

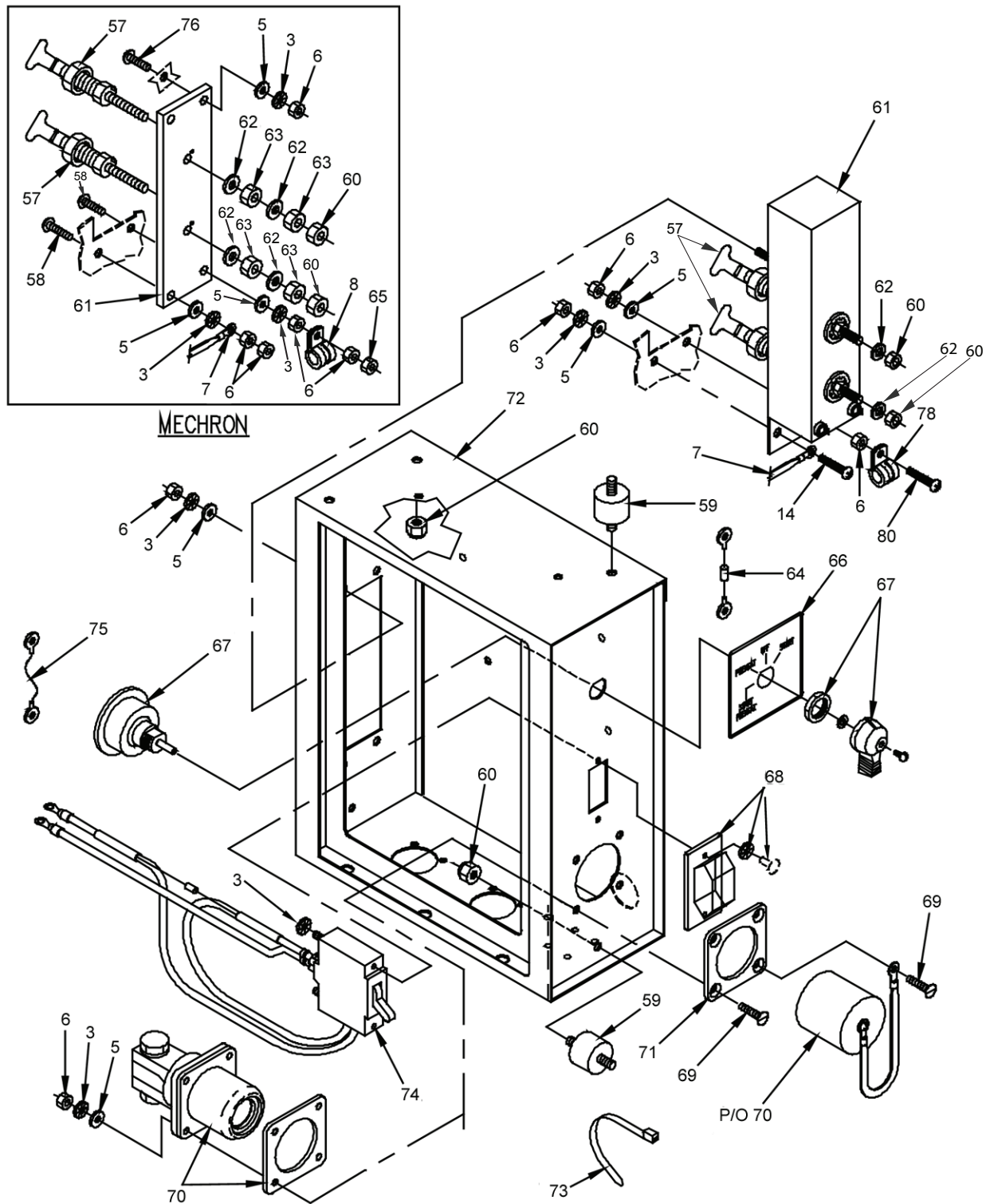

Figure 21. Control Panel Assembly (MEP-531A) (Sheet 3 of 3).

(1)	(2)		(3)	(4)	(5)	(6)	(7)
ITEM NO	SMR CODE		NSN	CAGEC	PART NUMBER	DESCRIPTION AND USABLE ON CODE (UOC)	QTY
	a. ARMY	b. AIR FORCE					
GROUP 04 CONTROL PANEL ASSEMBLY (MEP-531A)							
FIG. 21 CONTROL PANEL ASSEMBLY (MEP-531A)							
1	PAFZZ	PAOZZ	6625-99-562-7769	K6197	083-41S2-211485	. METER, FREQUENCY	1
2	PAFZZ	PAOZZ	6620-01-467-7577	OBHF9	0200A1805AB0001	. VOLTMETER, AC	1
3	XBFZZ	XBOZZ		97403	13230E6743-73	. WASHER, LOCK, FLAT	12
4	PAFZZ	PAOZZ	6625-99-623-6974	K6197	083-75A2-211841	. AMMETER	1
5	XBFZZ	XBOZZ		30554	88-20564-18	. WASHER, FLAT	10
6	XBFZZ	XBOZZ		30554	95-8159-8	. NUT, PLAIN, HEX (MEP-531A)	10
6	XBFZZ	XBOZZ		30554	95-8159-8	. NUT, PLAIN, HEX (MECHRON 120 VAC)	12
7	XBFZZ	XBOZZ		30554	95-8024-1	. STRAP, GROUND	1
8	XBFZZ	XBOZZ		22175	44LC76WDC-7YN	. CLAMP, LOOP, CUSH-ION (MEP-531A)	1
8	XBFZZ	XBOZZ		22175	44LC76WDC-6YN	. CLAMP, LOOP, CUSH-ION (MECHRON 120 VAC)	2
9	AOFFF	AOOOO		30554	95-8077	. POTENTIOMETER, VOLT. BREAK-DOWN, SEE FIGURE 24	1
10	XBFZZ	XBOZZ		30554	95-8159-3	. NUT, PLAIN, HEX	2
11	XBFZZ	XBOZZ		30554	88-20564-17	. WASHER, FLAT	6
12	XBFZZ	XBOZZ		BRYAN	GFR83FT	. RECEPTACLE, GROUND	1
13	PAFZZ	PAOZZ	5975-01-090-8876	81703	30451	. COVER, RECEPTACLE	1
14	XBFZZ	XBOZZ		97403	13218E0493-2767PIC	. SCREW, MACHINE (MECHRON)	1
14	XBFZZ	XBOZZ		97403	13218E0493-2767PIC	. SCREW, MACHINE (MEP-531A)	2
15	XBFZZ	XBOZZ		97403	13230E6743-71	. WASHER, LOCK, FLAT	6
16	XBFZZ	XBOZZ		97403	13218E0493-1287PIC	. SCREW, MACHINE	4
17	XBFZZ	XBOZZ		81349	M24243/6-A402H	. RIVET, BLIND	16
18	PAFZZ	PAOZZ	5920-00-280-8342	81349	F02A250V1A	. FUSE, CARTRIDGE	2
19	PAFZZ	PAOZZ	5920-01-005-9621	59873	352-0362-00	. FUSEHOLDER, EXTRACT	2
20	XBFZZ	XBOZZ		30554	95-8013	. PLATE, INSTRUMENT	1
21	XBFZZ	XBOZZ		51506	1250-R-SS-625-12	. STANDOFF, FEMALE (MEP-531A)	1
21	XBFZZ	XBOZZ		55566	4077-1032-SS-20	. STANDOFF, MALE-FEMALE (MECHRON 120 VAC)	1
22	XBFZZ	XBOZZ		30554	95-8048	. PLATE, INSTRUCTION	1
23	XBFZZ	XBOZZ		30554	95-8060	. PLATE, IDENTIFICATION	1
24	PAFZZ	PAOZZ	6645-01-458-7278	74400	85311	. METER, TIME TOTALIZING	1
25	PAFZZ	PAOZZ	5340-01-472-8707	30554	95-8184	. COVER, PROTECTIVE	1
26	XBFZZ	XBOZZ		30554	M4X0.7X22M	. SCREW, PAN HEAD	3
27	XBFZZ	XBOZZ	5310-01-458-7561	97403	13230E6744-42	. WASHER, LOCK-SPRING	3
28	XBFZZ	XBOZZ		30554	88-20564-24	. WASHER, FLAT	3
29	PAFZZ	PAFZZ	6110-01-465-5952	30554	95-8076	. VOLTAGE REGULATOR	1
30	XBFZZ	XBFZZ		97403	13218E0493-1296PIC	. SCREW, MACHINE	2
31	XBFZZ	XBOZZ		97403	13230E6744-41	. WASHER, LOCK-SPRING	2
32	PAFZZ	PAOZZ	5325-00-174-9038	70485	804	. GROMMET, NONMETALLIC	1
33	XBFZZ	XBOZZ		30554	95-8026	. GUIDE, CABLE	1
34	XBFZZ	XBOZZ	5310-01-411-0862	80204	B1822BH030R	. WASHER, FLAT	4
35	XBFZZ	XBOZZ		80204	B18212HRRN030	. WASHER, LOCK-SPRING	4
36	XBFZZ	XBOZZ	5305-01-391-3563	80204	B1867EC030080	. SCREW, MACHINE	4

(1)	(2)		(3)	(4)	(5)	(6)	(7)
ITEM NO	SMR CODE		NSN	CAGEC	PART NUMBER	DESCRIPTION AND USABLE ON CODE (UOC)	QTY
	a. ARMY	b. AIR FORCE					
37	XBFZZ	XBOZZ		30554	88-20564-2	. WASHER, FLAT	2
38	XBFZZ	XBOZZ	5310-01-467-6832	97403	13230E6744-44	. WASHER, LOCK-SPRING	2
39	XBFZZ	XBOZZ		30554	88-22790-1	. NUT, HEXAGON	2
40	XBFFF	XBOOO		30554	95-8019-2	. SOLENOID VALVE ASSY BREAK-DOWN, SEE FIGURE 25.....	1
41	XBFZZ	XBOZZ	5305-01-435-4122	80204	B1867BC040060	. SCREW, MACHINE	2
42	XBFZZ	XBOZZ	5305-00-225-3843	80204	B1821BH025C100N	. SCREW, CAP, HEXAGON	1
43	XBFZZ	XBOZZ		30554	95-8047-1	. GASKET, CONNECTOR	2
44	XBFFF	XBOOO		30554	95-8084	. WIRING HARNESS, CON. BREAK-DOWN, SEE FIGURE 26.....	1
45	XBFZZ	XBOZZ		30554	88-20564-23	. WASHER, FLAT	8
46	XBFZZ	XBOZZ		97403	13230E6743-70	. WASHER, LOCK, FLAT	8
47	XBFZZ	XBOZZ		97403	13218E0493-1249PIC	. SCREW, MACHINE	8
48	XBFFF	XBOOO		30554	95-8075	. WIRING HARNESS, CON. BREAK-DOWN, SEE FIGURE 27.....	1
49	XBFZZ	XBFZZ		97403	13218E0493-1285PIC	. SCREW, MACHINE	2
50	PBFZZ	PBFZZ	6110-01-474-8025	14058	41435-501	. CONTROL, GENERATOR	1
51	PAFZZ	PAFZZ	5940-00-243-0409	06383	P14-6R	. TERMINAL, LUG	8
52	MOFZZ	MOOZZ		30554	95-8021-92	. SLEEVING, INSULATION MAKE FROM ST-301-3/16 BLACK, WP 0153, BULK, ITEM 12, 8 IN. REQUIRED	1
53	PAFZZ	PAOZZ	5905-01-465-3266	30554	95-8027	. DISCHARGE VARISTOR	1
54	XBFZZ	XBOZZ	6150-00-632-7234	80063	SM-A-57192-53	. BUS, CONDUCTOR	1
55	XBFZZ	XBOZZ		97403	13218E0493-1289PIC	. SCREW, MACHINE	2
56	XBFZZ	XBOZZ	5940-01-233-1810	73631	1516	. BOARD, TERMINAL	1
57	PAFZZ	PAOZZ	5940-00-021-3321	82168	DG3M2F-S-RPC	. TERMINAL, STUD (MECHRON 120 VAC)	2
58	XBFZZ	XBOZZ		97403	13218E0493-2771PIC	. SCREW, MACHINE (MECHRON 120 VAC)	2
59	PAFZZ	PAOZZ		81860	A22-131	. MOUNT, RESILIENT	4
60	XBFZZ	XBOZZ	5342-01-324-0772	019L2	79NE-040	. NUT, SELF-LOCKING	6
61	XBFFF	XBOOO		OAM43	F18356	. FILTER, ELECTRO MAGNETIC INTERFERENCE (EMI) (MEP-531A)	1
61	XBFZZ	XBOZZ		30554	95-8149	. BOARD, LOAD TERMINAL (MECHRON 120 VAC).....	1
62	XBFZZ	XBOZZ		30554	88-20564-26	. WASHER, FLAT (MEP-531A).....	2
62	XBFFF	XBOOO		30554	88-20564-19	. WASHER, FLAT (MECHRON 120 VAC)	4
63	XBFZZ	XBOZZ		30554	88-22336-3	. NUT, HEX, JAM (MECHRON 120 VAC)	4
64	XBFFF	XBOOO		30554	95-8050	. FLYWHEEL DIODE ASSY BREAK-DOWN, SEE FIGURE 28.....	1
65	XBFZZ	XBOZZ		019L2	79NM-02	. NUT, SELF-LOCKING (MECHRON 120 VAC).....	1
66	XBFZZ	XBOZZ		30554	95-8015	. PLATE, INSTRUCTION	1
67	PAFZZ	PAOZZ	5930-01-419-6559	13445	95509-01	. SWITCH, ROTARY	1
68	PAFZZ	PAOZZ	5975-00-992-8396	97942	342C698H06	. BOOT, DUST AND MOIS.	1
69	XBFZZ	XBOZZ		30554	95-8158-274	. SCREW, MACHINE FLAT	4
70	XBFZZ	XBOZZ	5935-01-097-9974	19207	11674728	. CONNECTOR, RECEPTACLE	1
71	XBFZZ	XBOZZ		30554	95-8018	. BRACKET, SLAVE RECEPT.	1
72	XBFFF	XBOOO		30554	95-8066	. PANEL CONSTRUCTION BREAK-DOWN, SEE FIGURE 23.....	1
73	XBFZZ	XBOZZ	5975-00-111-3208	43999	LE127-0011-0005	. STRAP, TIEDOWN	1
74	PAFZZ	PAOZZ	5925-01-464-2030	30554	95-8078	. FLYWHEEL DIODE ASSY	1

(1)	(2)		(3)	(4)	(5)	(6)	(7)
ITEM NO	SMR CODE		NSN	CAGEC	PART NUMBER	DESCRIPTION AND USABLE ON CODE (UOC)	QTY
	a. ARMY	b. AIR FORCE					
75	AOFFF	AOOOO		30554	95-8166	. LEAD, ELECTRICAL BREAK- DOWN, SEE FIGURE 29.....	1
76	XBFZZ	XBOZZ		97403	13218E0493-2769PIC	. SCREW, MACHINE (MECHRON 120 VAC)	2
77	XBFZZ	XBOZZ		97403	13218E0493-2764PIC	. SCREW, MACHINE (MEP-531A).....	1
78	XBFZZ	XBOZZ		22175	44LC76WDC-8YN	. CLAMP, LOOP (MEP-531A).....	1
79	XBFZZ	XBOZZ		30554	88-20564-27	. WASHER, FLAT (MEP-531A).....	2
80	XBFZZ	XBOZZ		97403	13218E0493-2771PIC	. SCREW, MACHINE (MEP-531A).....	1

END OF FIGURE

OPERATOR AND FIELD MAINTENANCE
2 kW MEP-501A/531A MILITARY TACTICAL GENERATOR SETS
GROUP 04 CONTROL PANEL ASSEMBLY (MEP-501A)

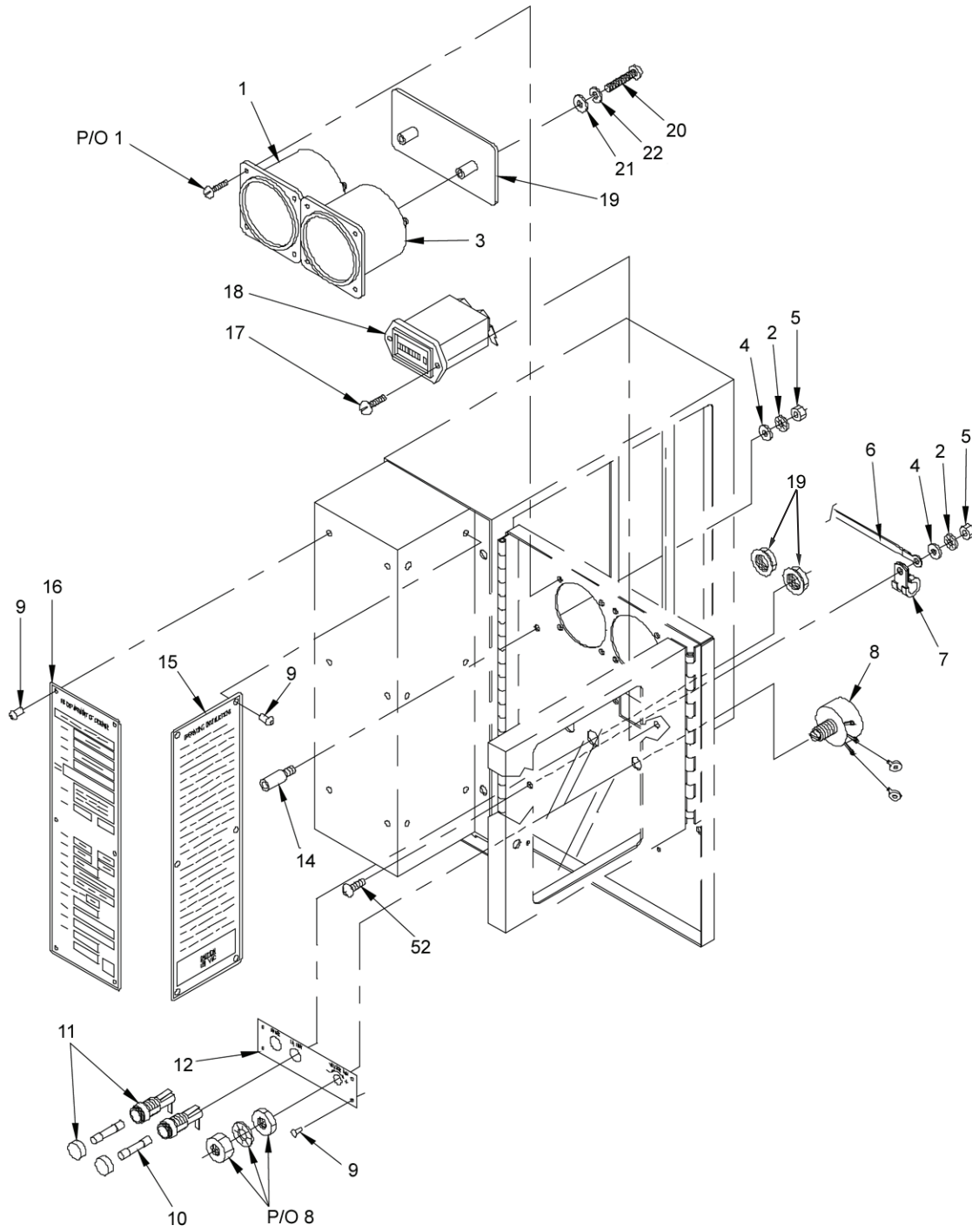

Figure 22. Control Panel Assembly (MEP-501A) (Sheet 1 of 3).

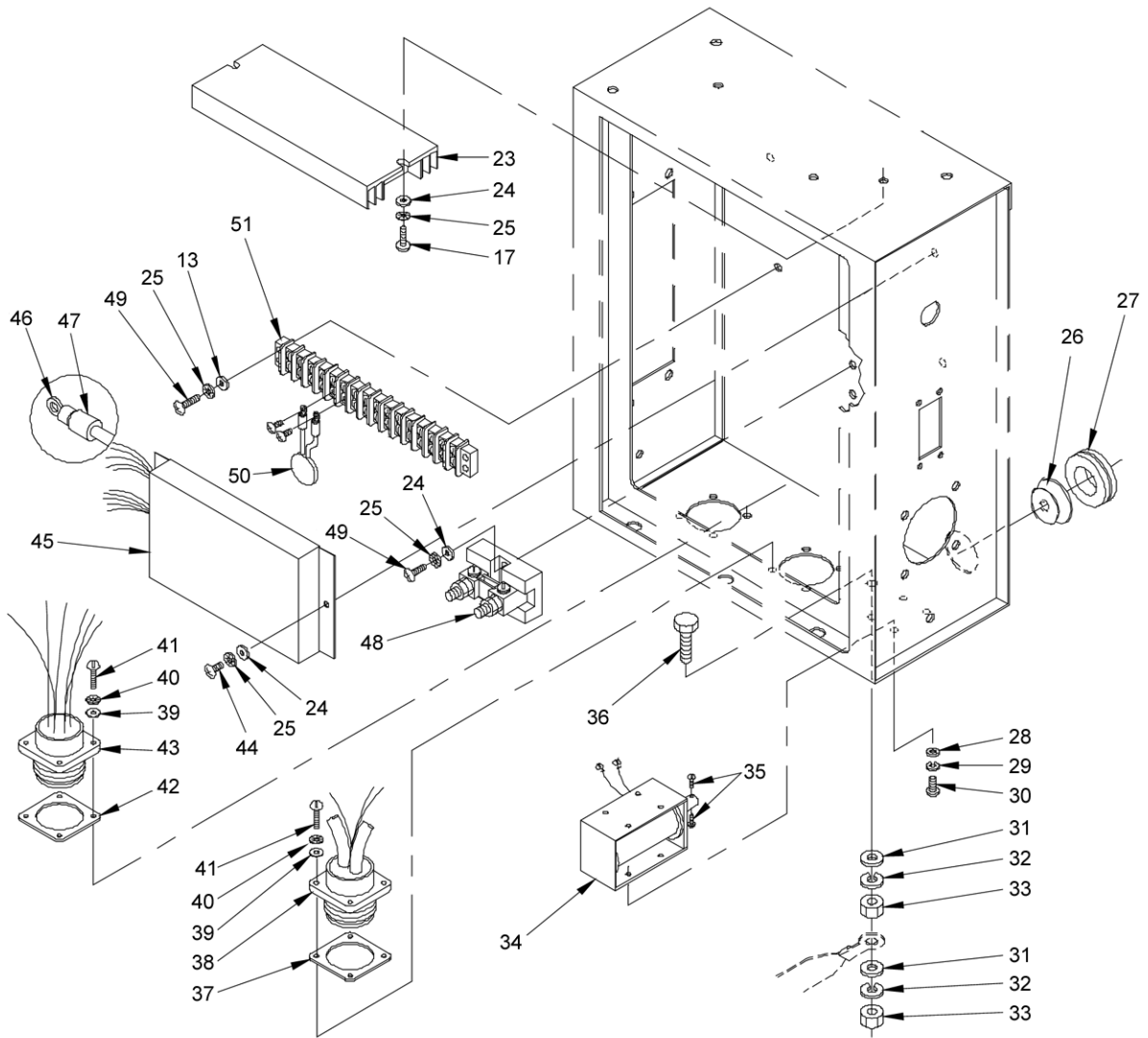

Figure 22. Control Panel Assembly (MEP-501A) (Sheet 2 of 3).

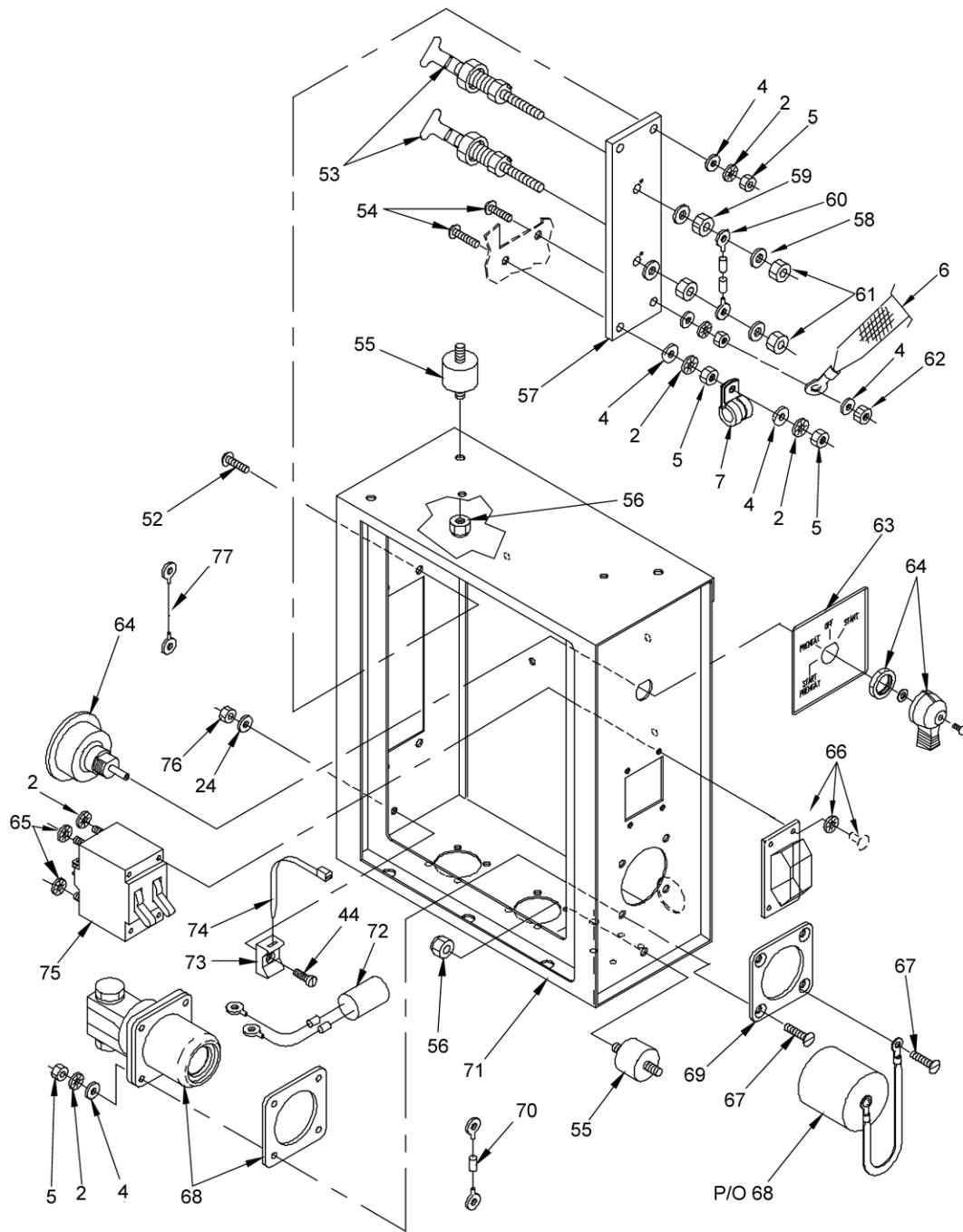

Figure 22. Control Panel Assembly (MEP-501A) (Sheet 3 of 3).

(1)	(2)		(3)	(4)	(5)	(6)	(7)
ITEM NO	SMR CODE		NSN	CAGEC	PART NUMBER	DESCRIPTION AND USABLE ON CODE (UOC)	QTY
	a. ARMY	b. AIR FORCE					
GROUP 04 CONTROL PANEL ASSEMBLY (MEP-501A)							
FIG. 22 CONTROL PANEL ASSEMBLY (MEP-501A)							
1	PAFZZ	PAOZZ		K6197	083-80V2-211843	. VOLTMETER, DC	1
2	XBFZZ	XBOZZ		97403	13230E6743-73	. WASHER, LOCK, FLAT	13
3	PAFZZ	PAOZZ	6625-99-629-8742	K6197	083-80A2-211844	. AMMETER	1
4	XBFZZ	XBOZZ		30554	88-20564-18	. WASHER, FLAT	12
5	XBFZZ	XBOZZ		30554	95-8159-8	. NUT, PLAIN, HEX	11
6	XBFZZ	XBOZZ		30554	95-8024-1	. STRAP, GROUND	1
7	XBFZZ	XBOZZ		22175	44LC76WDC-6YN	. CLAMP, LOOP, CUSHION	2
8	AOFFF	AOOOO		30554	95-8014	. POTENTIOMETER, VOLT. BREAK-DOWN, SEE FIGURE 24.....	1
9	XBFZZ	XBOZZ	5320-00-932-1972	81349	M24243/6-A402H	. RIVET, BLIND	16
10	PAFZZ	PAOZZ	5920-00-280-8342	81349	F02A250V1A	. FUSE, CARTRIDGE	2
11	PAFZZ	PAOZZ	5920-01-005-9621	59873	352-0362-00	. FUSEHOLDER, EXTRACT	2
12	XBFZZ	XBOZZ		30554	95-8013	. PLATE, INSTRUMENT	1
13	XBFZZ	XBOZZ		30554	88-20564-27	. WASHER, FLAT	2
14	XBFZZ	XBOZZ		55566	4077-1032-SS-20	. STANDOFF, MALE-FEMALE	1
15	XBFZZ	XBOZZ		30554	95-8011	. PLATE, INSTRUCTION	1
16	XBFZZ	XBOZZ		30554	95-8010	. PLATE, IDENTIFICATION	1
17	XBFZZ	XBOZZ		97403	13218E0493-1287PIC	. SCREW, MACHINE	4
18	PAFZZ	PAOZZ	6645-01-458-7278	74400	85311	. METER, TIME TOTALIZING	1
19	PAFZZ	PAOZZ		30554	95-8185	. COVER, PROTECTIVE	1
20	XBFZZ	XBOZZ		30554	M4X0.7X22M	. SCREW, PAN HEAD	2
21	XBFZZ	XBOZZ		30554	88-20564-24	. WASHER, FLAT	2
22	XBFZZ	XBOZZ	5310-01-458-7561	97403	13230E6744-42	. WASHER, LOCK-SPRING	2
23	PAFZZ	PAFZZ	6110-01-419-3179	55156	20124SR	. REGULATOR, VOLTAGE	1
24	XBFZZ	XBOZZ		30554	88-20564-17	. WASHER, FLAT	7
25	XBFZZ	XBOZZ		97403	13230E6743-71	. WASHER, LOCK, FLAT	8
26	XBFZZ	XBOZZ		30554	95-8026	. GUIDE, CABLE	1
27	PAFZZ	PAOZZ	5325-00-174-9038	70485	804	. GROMMET, NONMETALLIC	1
28	XBFZZ	XBOZZ	5310-01-411-0862	80204	B1822BH030R	. WASHER, FLAT	4
29	XBFZZ	XBOZZ		80204	B18212HRRN030	. WASHER, LOCK-SPRING	4
30	XBFZZ	XBOZZ	5305-01-391-3563	80204	B1867EC030080	. SCREW, MACHINE	4
31	XBFZZ	XBOZZ		30554	88-20564-2	. WASHER, FLAT	2
32	XBFZZ	XBOZZ		97403	13230E6744-44	. WASHER, LOCK-SPRING	2
33	XBFZZ	XBOZZ		30554	88-22790-1	. NUT, HEXAGON	2
34	XBFFF	XBOOO		30554	95-8019-1	. SOLENOID VALVE ASSY BREAK-DOWN, SEE FIGURE 25.....	1
35	XBFZZ	XBOZZ	5305-01-435-4122	80204	B1867BC040060	. SCREW, MACHINE	2
36	XBFZZ	XBOZZ	5305-00-225-3843	80204	B1821BH025C100N	. SCREW, CAP, HEXAGON	1
37	XBFZZ	XBOZZ		30554	95-8047-1	. GASKET, CONNECTOR	1
38	XBFFF	XBOOO		30554	95-8023	. WIRING HARNESS, CON. BREAK-DOWN, SEE FIGURE 26.....	1
39	XBFZZ	XBOZZ		30554	88-20564-23	. WASHER, FLAT	8
40	XBFZZ	XBOZZ		97403	13230E6743-70	. WASHER, LOCK, FLAT	8
41	XBFZZ	XBOZZ		97403	13218E0493-1249PIC	. SCREW, MACHINE	8
42	XBFZZ	XBOZZ		30554	95-8047-2	. GASKET, CONNECTOR	1

(1)	(2)		(3)	(4)	(5)	(6)	(7)
SMR CODE							
ITEM NO	a.	b.	NSN	CAGEC	PART NUMBER	DESCRIPTION AND USABLE ON CODE (UOC)	QTY
	ARMY	AIR FORCE					
43	XBFFF	XBOOO		30554	95-8022	. WIRING HARNESS, CON. BREAK-DOWN, SEE FIGURE 27.....	1
44	XBFZZ	XBFZZ		97403	13218E0493-1285PIC	. SCREW, MACHINE	3
45	PBFZZ	PBFZZ		14058	41435-501	. CONTROL, GENERATOR	1
46	PAFZZ	PAFZZ	5940-00-243-0409	06383	P14-6R	. TERMINAL, LUG	9
47	MOFZZ	MOOZZ		30554	95-8005-99	. SLEEVING, INSULATION MAKE FROM ST-301-3/16 BLACK, WP 0153, BULK, ITEM 12, 8 IN. REQUIRED	1
48	XBFZZ	XBOZZ		K6197	871-92V3-000029	. SHUNT, INSTRUMENT	1
49	XBFZZ	XBOZZ		97403	13218E0493-1289PIC	. SCREW, MACHINE	4
50	PAFZZ	PAOZZ		30554	95-8027	. DISCHARGE VARISTOR	1
51	XBFZZ	XBOZZ		73631	1514	. TERMINAL BOARD, MOLD.	1
52	XBFZZ	XBOZZ		97403	13218E0493-2769PIC	. SCREW, MACHINE	3
53	PAFZZ	PAOZZ	5940-00-958-1214	82168	DG3M6F-S-RPC	. TERMINAL, STUD	2
54	XBFZZ	XBOZZ		97403	13218E0493-2771PIC	. SCREW, MACHINE	2
55	PAFZZ	PAOZZ	5342-01-324-0772	81860	A22-131	. MOUNT, RESILIENT	4
56	XBFZZ	XBOZZ		019L2	79NE-040	. NUT, SELF-LOCKING	4
57	XBFZZ	XBOZZ		30554	95-8016	. BOARD, LOAD TERMINAL	1
58	XBFZZ	XBOZZ		30554	88-20564-25	. WASHER, FLAT	4
59	XBFZZ	XBOZZ	5310-00-189-8467	63857	BS4-1801PC15	. NUT, PLAIN, HEXAGON	2
60	AOFFF	AOOOO		30554	95-8025	. TRANSIENT SUPPRESSOR BREAK-DOWN, SEE FIGURE 32.....	1
61	XBFZZ	XBOZZ		019L2	79NE-083	. NUT, SELF-LOCKING	2
62	XBFZZ	XBOZZ		019L2	79NM-02	. NUT, SELF-LOCKING	1
63	XBFZZ	XBOZZ		30554	95-8015	. PLATE, INSTRUCTION	1
64	PAFZZ	PAOZZ	5930-01-419-6559	13445	95509-01	. SWITCH, ROTARY	1
65	XBFZZ	XBOZZ		97403	13230E6743-74	. WASHER, LOCK, FLAT	2
66	PAFZZ	PAOZZ	5925-00-267-1447	81349	M5423/14-06	. BOOT, DUST AND MOIS.	1
67	XBFZZ	XBOZZ		30554	95-8158-274	. SCREW, MACHINE FLAT	4
68	XBFZZ	XBOZZ	5935-01-097-9974	19207	11674728	. CONNECTOR, RECEPTACLE	1
69	XBFZZ	XBOZZ		30554	95-8018	. BRACKET, SLAVE RECEP.	1
70	XBFFF	XBOOO		30554	95-8050	. FLYWHEEL DIODE ASSY BREAK-DOWN, SEE FIGURE 28.....	1
71	XBFFF	XBOOO		30554	95-8006	. PANEL CONSTRUCTION BREAK-DOWN, SEE FIGURE 23.....	1
72	AOFFF	AOOOO		30554	95-8017	. CAPACITOR ASSEMBLY BREAK-DOWN, SEE FIGURE 31.....	1
73	XBFZZ	XBOZZ		06383	TM3S8-C100	. MOUNT, CABLE TIE	1
74	XBFZZ	XBOZZ	5975-00-111-3208	43999	LE127-0011-0005	. STRAP, TIEDOWN, ELEC.	1
75	PAFZZ	PAOZZ		74193	AM2S-Z272-1	. CIRCUIT BREAKER, 2-POLE	1
76	XBFZZ	XBOZZ		019L2	79NM-62	. NUT, SELF-LOCKING	1
77	AOFFF	AOOOO		30554	95-8056	. LEAD, ELECTRICAL BREAK-DOWN, SEE FIGURE 30.....	1

END OF FIGURE

OPERATOR AND FIELD MAINTENANCE

**2 KW MEP-501A/531A MILITARY TACTICAL GENERATOR SETS
GROUP 0401 CONTROL PANEL CONSTRUCTIONS (MEP-531A/501A)**

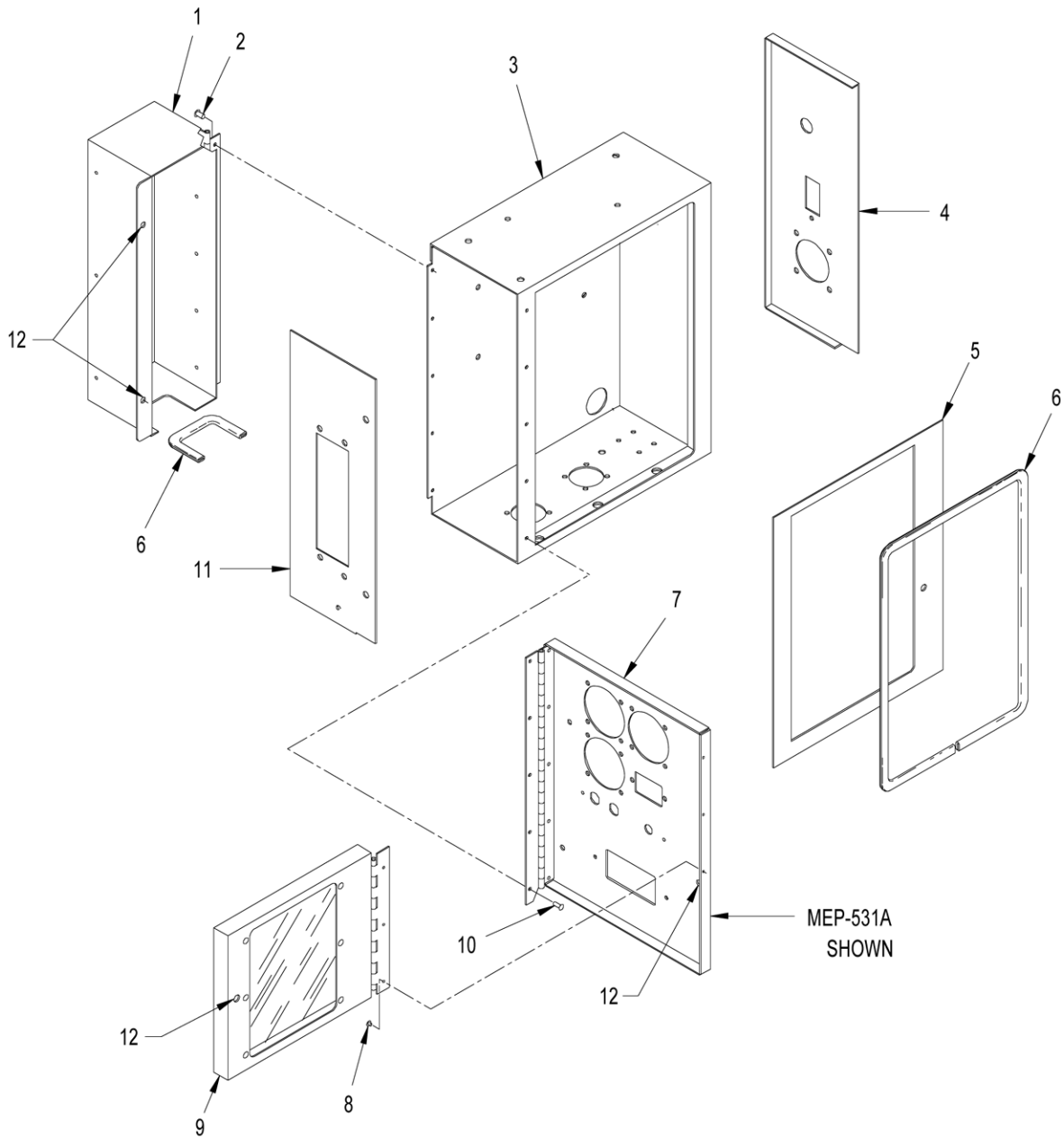

Figure 23. Control Panel Constructions (MEP-531A/501A).

(1)	(2)		(3)	(4)	(5)	(6)	(7)
ITEM NO	SMR CODE		NSN	CAGEC	PART NUMBER	DESCRIPTION AND USABLE ON CODE (UOC)	QTY
	a. ARMY	b. AIR FORCE					
GROUP 0401 CONTROL PANEL CONSTRUCTIONS (MEP-531A/501A)							
FIG. 23 CONTROL PANEL CONSTRUCTIONS (MEP-531A/501A)							
1	XBFZZ	XBOZZ		30554	95-8176	. LUG COVER ASSY	1
2	XBFZZ	XBOZZ	5320-00-882-8388	81349	M24243/6-A403H	. RIVET, BLIND	7
3	XBFZZ	XBOZZ		30554	95-8068	. HOUSING, CTROL PNL (MEP-531A)	1
3	XBFZZ	XBOZZ		30554	95-8085	. HOUSING, CTROL PNL (MEP-501A)	1
4	XBFZZ	XBOZZ		30554	95-8067	. PANEL, RIGHT (MEP-531A)	1
4	XBFZZ	XBOZZ		30554	95-8086	. PANEL, RIGHT (MEP-501A)	1
5	XBFZZ	XBOZZ		30554	95-8091	. PANEL, FRONT	1
6	MOFZZ	MOOZZ		30554	95-8066-14	. PROTECTOR, EDGE (MEP-531A) MAKE FROM RW-25SBR, WP 0153, BULK, ITEM 7, 45 IN. REQUIRED	1
6	MOFZZ	MOOZZ		30554	95-8006-14	. PROTECTOR, EDGE (MEP-501A) MAKE FROM RW-25SBR, WP 0153, BULK, ITEM 7, 45 IN. REQUIRED	1
7	XBFZZ	XBOZZ		30554	95-8179	. PANEL, DOOR CONSTR. (MEP-531A)	1
7	XBFZZ	XBOZZ		30554	95-8178	. PANEL, DOOR ASSY (MEP-501A).....	1
8	XBFZZ	XBOZZ		11815	BSP-32	. RIVET, BLIND, PRO.	3
9	XBFZZ	XBOZZ		30554	95-8177	. COVER, INSTR ASSY	1
10	XBFZZ	XBOZZ	5320-00-932-1972	81349	M24243/6-A402H	. RIVET, BLIND	39
11	XBFZZ	XBOZZ		30554	95-8087	. PANEL, LEFT	1
12	XBFZZ	XBOZZ	5305-01-419-3551	94222	47-62-512-50	. FASTENER, PNL	4

END OF FIGURE

OPERATOR AND FIELD MAINTENANCE
2 kW MEP-501A/531A MILITARY TACTICAL GENERATOR SETS
GROUP 0402 VOLTAGE ADJUST POTENTIOMETER

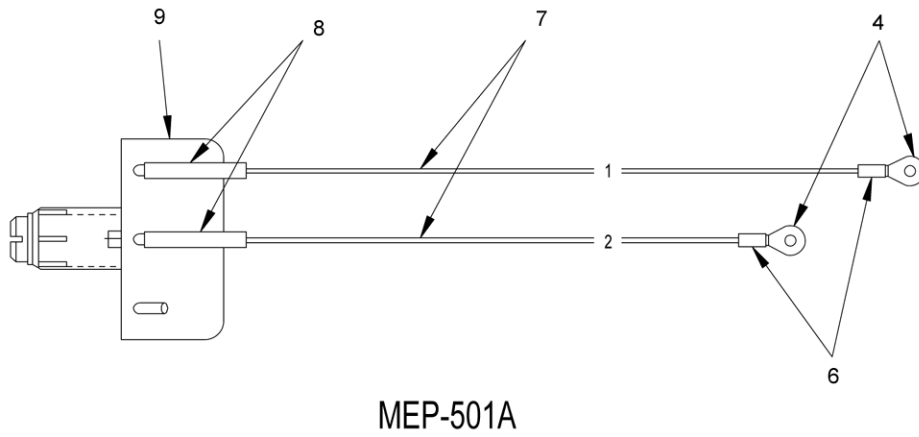
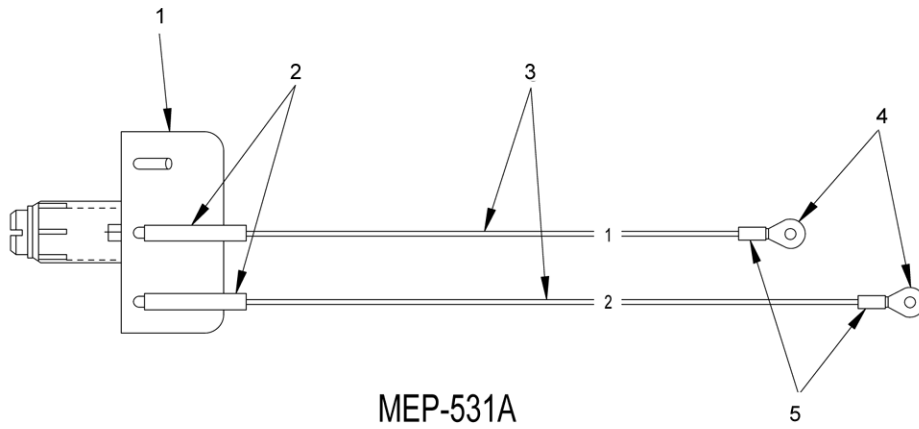

Figure 24. Voltage Adjust Potentiometer.

(1)	(2)		(3)	(4)	(5)	(6)	(7)
ITEM NO	SMR CODE		NSN	CAGEC	PART NUMBER	DESCRIPTION AND USABLE ON CODE (UOC)	QTY
	a. ARMY	b. AIR FORCE					

GROUP 0402 VOLTAGE ADJUST POTENTIOMETER

FIG. 24 VOLTAGE ADJUST POTENTIOMETER

1	PAFZZ	PAOZZ	5905-00-646-5958	81349	RV4LAYS A102A	. POTENTIOMETER	1
2	MOFZZ	MOOZZ		30554	95-8077-3	. SLEEVING, INSULATION MAKE FROM ST-301-1/8 BLACK, WP 0153, BULK, ITEM 8, 1 IN. REQUIRED	1
3	MOFZZ	MOOZZ		30554	95-8077-4	. WIRE, ELECTRICAL 16 MAKE FROM 16878/3BJE-9, WP 0153, BULK, ITEM 9, APPROX. 49 IN. REQUIRED	1
4	PAFZZ	PAOZZ	5940-00-243-0409	06383	P14-6R	. TERMINAL, LUG	2
5	MOFZZ	MOOZZ		30554	95-8077-5	. SLEEVING, INSULATION MAKE FROM ST-301-3/16 BLACK, WP 0153, BULK, ITEM 12, 2 IN. REQUIRED	1
6	MOFZZ	MOOZZ		30554	95-8014-5	. SLEEVING, INSULATION MAKE FROM ST-301-3/16 BLACK, WP 0153, BULK, ITEM 12, 2 IN. REQUIRED	1
7	MOFZZ	MOOZZ		30554	95-8014-4	. WIRE, ELECTRICAL 16 MAKE FROM 16878/3BJE-9, WP 0153, BULK, ITEM 9, APPROX. 46 IN. REQUIRED	1
8	MOFZZ	MOOZZ		30554	95-8014-2	. SLEEVING, INSULATION MAKE FROM ST-301-1/8 BLACK, WP 0153, BULK, ITEM 8, 1 IN. REQUIRED.....	1
9	PAFZZ	PAOZZ	5905-00-665-4992	81349	RV4LAYS A104A	. POTENTIOMETER	1

END OF FIGURE

OPERATOR AND FIELD MAINTENANCE
2 kW MEP-501A/531A MILITARY TACTICAL GENERATOR SETS
GROUP 0407 LOP SHUTDOWN SOLENOID ASSEMBLY

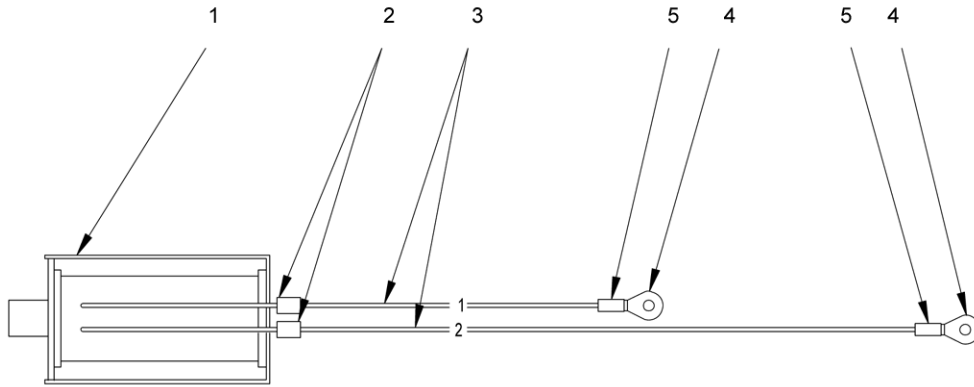

Figure 25. LOP Shutdown Solenoid Assembly.

(1)	(2)		(3)	(4)	(5)	(6)	(7)
ITEM NO	SMR CODE		NSN	CAGEC	PART NUMBER	DESCRIPTION AND USABLE ON CODE (UOC)	QTY
	a. ARMY	b. AIR FORCE					
						GROUP 0407 LOP SHUTDOWN SOLENOID ASSEMBLY	
						FIG. 25 LOP SHUTDOWN SOLENOID ASSEMBLY	
1	PAFZZ	PAOZZ	5945-01-416-0380	0AK42	183266-91690	. SOLENOID, ELECTRICAL	1
2	PAFZZ	PAOZZ	5940-00-636-5536	00779	34068	. SPLICE, CONDUCTOR (MEP-531A).....	2
2	PAFZZ	PAOZZ	5940-00-636-5536	00779	34068	. SPLICE, CONDUCTOR (MEP-501A).....	2
3	MOFZZ	MOOZZ		30554	95-8019-4	. WIRE, ELECTRICAL 16 MAKE FROM 6878/3BJE-9, WP 0153, BULK, ITEM 9, 21-1/2 IN. REQUIRED	1
4	PAFZZ	PAOZZ	5940-00-243-0409	06383	P14-6R	. TERMINAL, LUG	2
5	MOFZZ	MOOZZ		30554	95-8019-5	. SLEEVING, INSULATION MAKE FROM ST-301-3/16 BLACK, WP 0153, BULK, ITEM 12, 2 IN. REQUIRED	1
						END OF FIGURE	

OPERATOR AND FIELD MAINTENANCE

2 KW MEP-501A/531A MILITARY TACTICAL GENERATOR SETS

GROUP 0408 CONTROL PANEL ENGINE WIRING HARNESSSES (MEP-531A/501A)

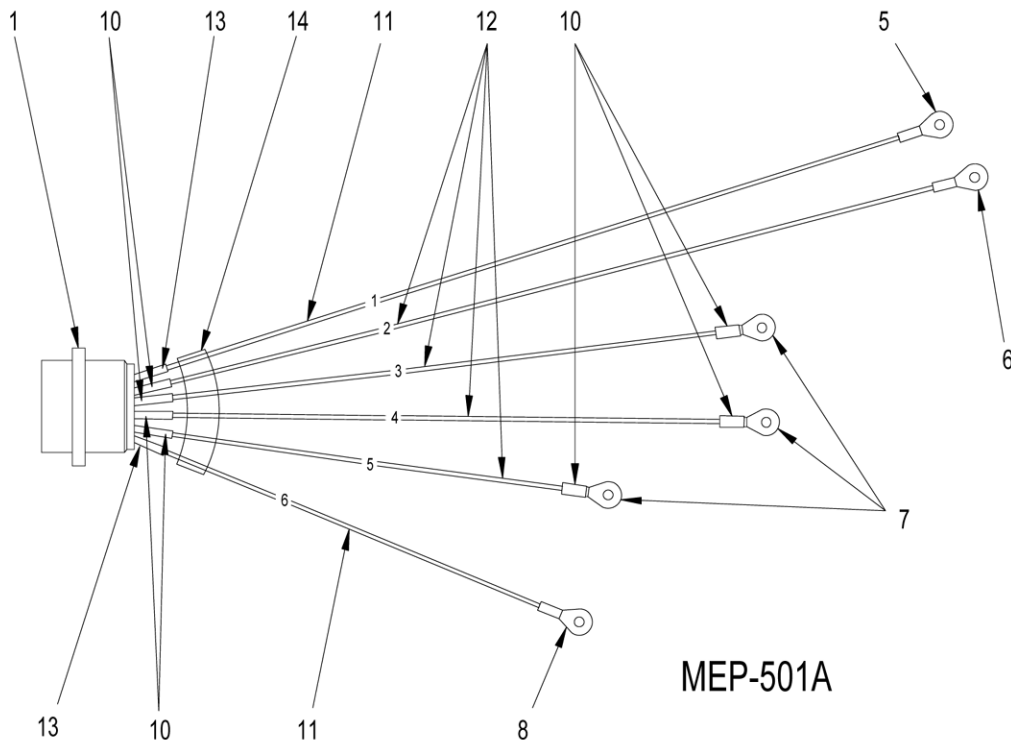
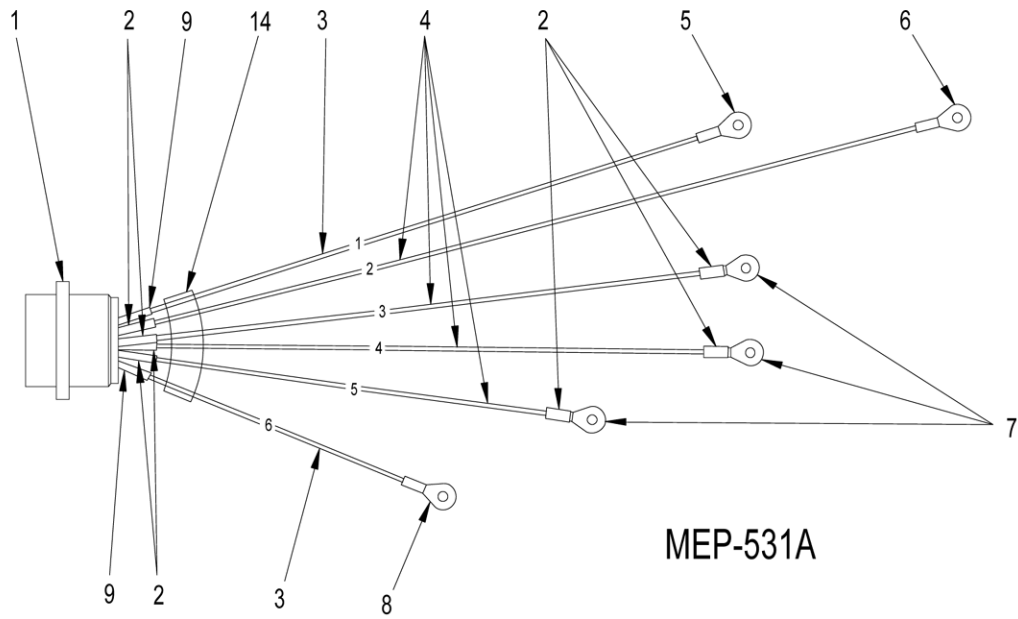

Figure 26. Control Panel Engine Wiring Harnesses (MEP-531A/501A).

(1)	(2)		(3)	(4)	(5)	(6)	(7)
ITEM NO	SMR CODE		NSN	CAGEC	PART NUMBER	DESCRIPTION AND USABLE ON CODE (UOC)	QTY
	a. ARMY	b. AIR FORCE					
GROUP 0408 CONTROL PANEL ENGINE WIRING HARNESSES (MEP-531A/501A)							
FIG. 26 CONTROL PANEL ENGINE WIRING HARNESSES (MEP-531A/501A)							
1	XBFZZ	XBOZZ		71468	CA3102R20-8P-F80	. CONNECTOR, RECEPTACLE	1
2	MOFZZ	MOOZZ		30554	95-8084-9	. SLEEVING, INSULATION MAKE FROM ST-301-3/16 BLACK, WP 0153, BULK, ITEM 12, 7 IN. REQUIRED	1
3	MOFZZ	MOOZZ		30554	95-8084-6	. WIRE, ELECTRICAL 8 MAKE FROM 16878/3BNL-9, WP 0153, BULK, ITEM 10, 21-1/2 IN. REQUIRED.....	1
4	MOFZZ	MOOZZ		30554	95-8084-7	. WIRE, ELECTRICAL 16 MAKE FROM M16878/3BJE-9, WP 0153, BULK, ITEM 9, 39-3/8 IN. REQUIRED.....	1
5	XBFZZ	XBOZZ	5940-01-465-3185	06383	PV8-10R-Q	. TERMINAL, LUG	1
6	XBFZZ	XBOZZ		98410	BB-837-10	. TERMINAL, LUG	1
7	XBFZZ	XBOZZ	5940-00-243-0409	06383	P14-6R	. TERMINAL, LUG	3
8	XBFZZ	XBOZZ	5940-01-465-4413	06383	PV8-38R-Q	. TERMINAL, LUG	1
9	MOFZZ	MOOZZ		30554	95-8084-8	. SLEEVING, INSULATION MAKE FROM ST-301-3/8 BLACK, WP 0153, BULK, ITEM 11, 2 IN. REQUIRED	1
10	MOFZZ	MOOZZ		30554	95-8023-2	. SLEEVING, INSULATION MAKE FROM ST-301-3/16 BLACK, WP 0153, BULK, ITEM 12, 7 IN. REQUIRED	1
11	MOFZZ	MOOZZ		30554	95-8023-8	. WIRE, ELECTRICAL 8 MAKE FROM M16878/3BNL-9, WP 0153, BULK, ITEM 10, 21-1/2 IN. REQUIRED	1
12	MOFZZ	MOOZZ		30554	95-8023-9	. WIRE, ELECTRICAL 16 MAKE FROM M16878/3BJE-9, WP 0153, BULK, ITEM 9, 39-3/8 IN. REQUIRED.....	1
13	MOFZZ	MOOZZ		30554	95-8023-7	. SLEEVING, INSULATION MAKE FROM ST-301-3/8 BLACK, WP 0153, BULK, ITEM 11, 2 IN. REQUIRED	1
14	MOFZZ	MOOZZ		30554	95-8084-10	. SLEEVING, INSULATION (MEP-531A) MAKE FROM ST-301-1-1/2 BLACK, WP 0153, BULK, ITEM 21, 3 IN. REQUIRED	1
14	MOFZZ	MOOZZ		30554	95-8023-10	. SLEEVING, INSULATION (MEP-501A) MAKE FROM ST-301-1-1/2 BLACK, WP 0153, BULK, ITEM 21, 3 IN. REQUIRED	1

END OF FIGURE

OPERATOR AND FIELD MAINTENANCE

2 KW MEP-501A/531A MILITARY TACTICAL GENERATOR SETS

GROUP 0409 CONTROL PANEL ALTERNATOR WIRING HARNESSSES (MEP-531A/501A)

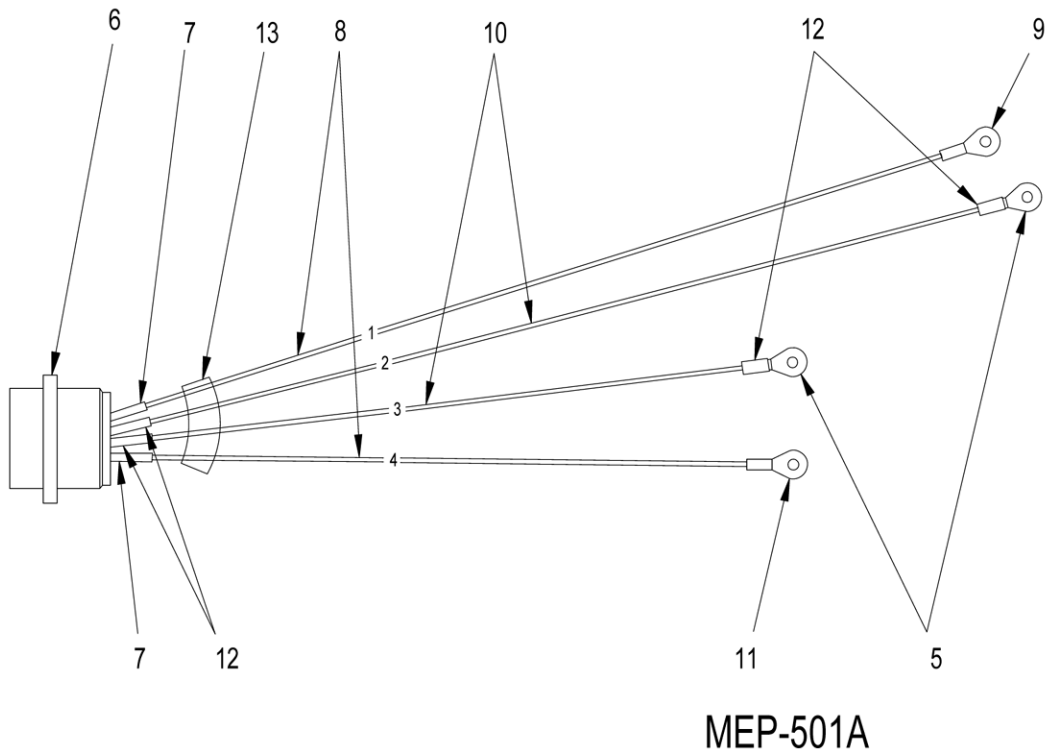
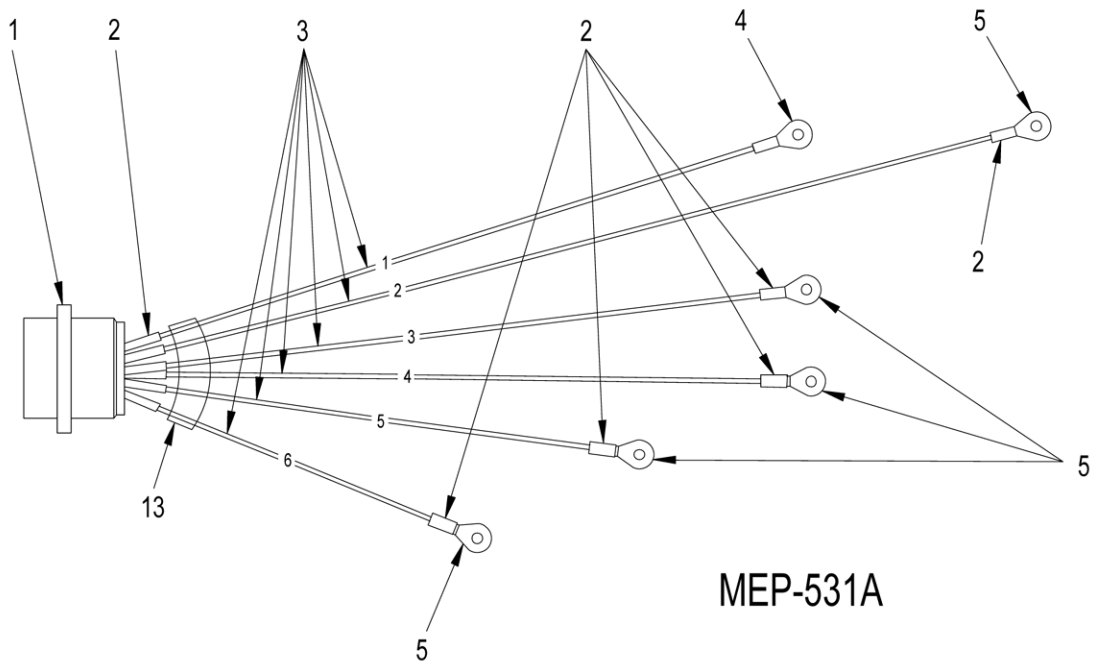

Figure 27. Control Panel Alternator Wiring Harnesses (MEP-531A/501A).

(1)	(2)		(3)	(4)	(5)	(6)	(7)
ITEM NO	SMR CODE		NSN	CAGEC	PART NUMBER	DESCRIPTION AND USABLE ON CODE (UOC)	QTY
	a. ARMY	b. AIR FORCE					
GROUP 0409 CONTROL PANEL ALTERNATOR WIRING HARNESSES (MEP-531A/501A)							
FIG. 27 CONTROL PANEL ALTERNATOR WIRING HARNESSES (MEP-531A/501A)							
1	XBFZZ	XBOZZ	5935-01-317-6752	71468	CA3102R20-15P-F80	. CONNECTOR, RECEPTACLE	1
2	MOFZZ	MOOZZ		30554	95-8075-4	. SLEEVING, INSULATION MAKE FROM ST-301-3/16 BLACK, WP 0153, BULK, ITEM 12, 11 IN. REQUIRED.....	1
3	MOFZZ	MOOZZ		30554	95-8075-5	. WIRE, ELECTRICAL 14 MAKE FROM 16878/3BKE-9, WP 0153, BULK, ITEM 13, 65-1/2 IN. REQUIRED.....	1
4	XBFZZ	XBOZZ	5940-00-230-0515	98410	BB-825-14	. TERMINAL, LUG	1
5	XBFZZ	XBOZZ		06383	P14-6R	. TERMINAL, LUG (MEP-531A)	5
5	XBFZZ	XBOZZ	5940-00-243-0409	06383	P14-6R	. TERMINAL, LUG (MEP-501A)	2
6	XBFZZ	XBOZZ		71468	CA3102R24-12P-F80	. CONNECTOR, RECEPTACLE	1
7	MOFZZ	MOOZZ		30554	95-8022-2	. SLEEVING, INSULATION MAKE FROM ST-301-3/8 BLACK, WP 0153, BULK, ITEM 11, 2 IN. REQUIRED	1
8	MOFZZ	MOOZZ		30554	95-8022-8	. WIRE, ELECTRICAL 4 MAKE FROM M16878/3BRL-9, WP 0153, BULK, ITEM 14, 9-1/2 IN. REQUIRED	1
9	XBFZZ	XBOZZ	5940-01-467-8197	06383	PV4-14R-E	. TERMINAL, LUG	1
10	MOFZZ	MOOZZ		30554	95-8022-7	. WIRE, ELECTRICAL 14 MAKE FROM 16878/3BKE-9, WP 0153, BULK, ITEM 13, 20-3/4 IN. REQUIRED.....	1
11	XBFZZ	XBOZZ	5940-01-467-8190	06383	PV4-12R-E	. TERMINAL, LUG	1
12	MOFZZ	MOOZZ		30554	95-8022-6	. SLEEVING, INSULATION MAKE FROM ST-301-3/16 BLACK, WP 0153, BULK, ITEM 12, 4 IN. REQUIRED	1
13	MOFZZ	MOOZZ		30554	95-8022-9	. SLEEVING, INSULATION (MEP-501A) MAKE FROM ST-301-1-1/2 BLACK, WP 0153, BULK, ITEM 21, 3 IN. REQUIRED	1
13	MOFZZ	MOOZZ		30554	95-8075-6	. SLEEVING, INSULATION (MEP-531A) MAKE FROM ST-301-1-1/2 BLACK, WP 0153, BULK, ITEM 21, 3 IN. REQUIRED	1
END OF FIGURE							

OPERATOR AND FIELD MAINTENANCE
2 kW MEP-501A/531A MILITARY TACTICAL GENERATOR SETS
GROUP 0411 FLYWHEEL DIODE ASSEMBLY

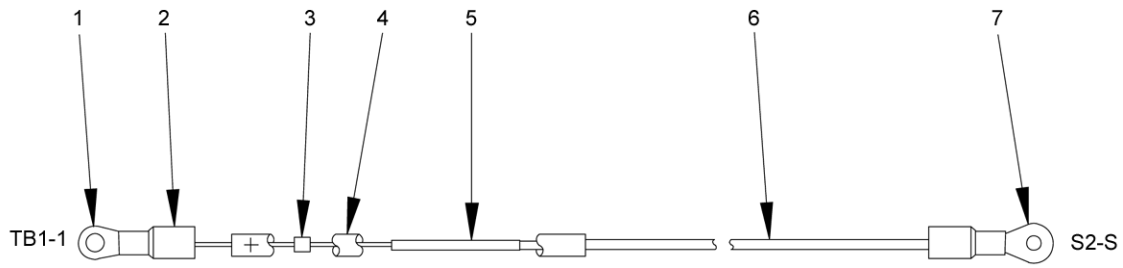

Figure 28. Flywheel Diode Assembly.

(1)	(2)		(3)	(4)	(5)	(6)	(7)
ITEM NO	SMR CODE		NSN	CAGEC	PART NUMBER	DESCRIPTION AND USABLE ON CODE (UOC)	QTY
	a. ARMY	b. AIR FORCE					
GROUP 0411 FLYWHEEL DIODE ASSEMBLY							
FIG. 28 FLYWHEEL DIODE ASSEMBLY							
1	XBFZZ	XBOZZ	5940-00-243-0409	06383	P14-6R	. TERMINAL, LUG	1
2	MOFZZ	MOOZZ		30554	95-8050-7	. SLEEVING, INSULATION MAKE FROM ST-301-3/16 BLACK, WP 0153, BULK, ITEM 12, 1 IN. REQUIRED	1
3	XBFZZ	XBOZZ	5961-00-997-8021	01295	IN4006	. SEMICONDUCTOR DEVICE	1
4	MOFZZ	MOOZZ		30554	95-8058-1	. MARKER, INSULATION MAKE FROM ST-301-3/16 WHITE, WP 0153, BULK, ITEM 15, APPROX. 3 IN. REQUIRED	1
5	XBFZZ	XBOZZ	5940-00-636-5536	00779	34068	. SPLICE, CONDUCTOR (MEP-531A)	1
5	XBFZZ	XBOZZ		00779	34068	. SPLICE, CONDUCTOR (MEP-501A)	1
6	MOFZZ	MOOZZ		30554	95-8050-6	. WIRE, ELECTRICAL 16 MAKE FROM 16878/3BJE-9, WP 0153, BULK, ITEM 9, 13-1/2 IN. REQUIRED	1
7	XBFZZ	XBOZZ	5940-00-143-4780	98410	BB-837-10	. TERMINAL, LUG	1

END OF FIGURE

OPERATOR AND FIELD MAINTENANCE

2 kW MEP-501A/531A MILITARY TACTICAL GENERATOR SETS

GROUP 0412 CONTROL PANEL ELECTRICAL LEADS (MEP-531A)

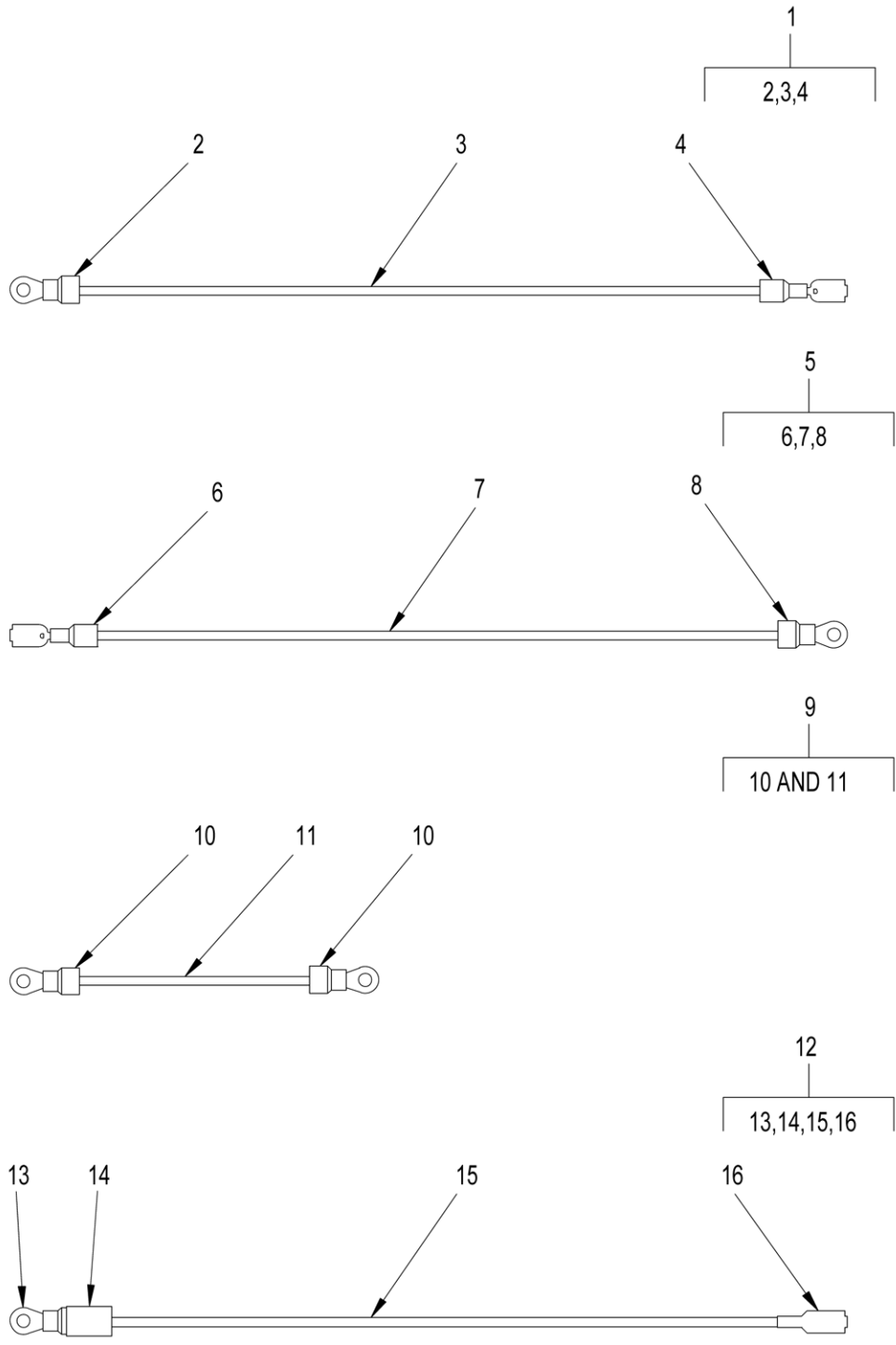

Figure 29. Control Panel Electrical Leads (MEP-531A) (Sheet 1 of 5).

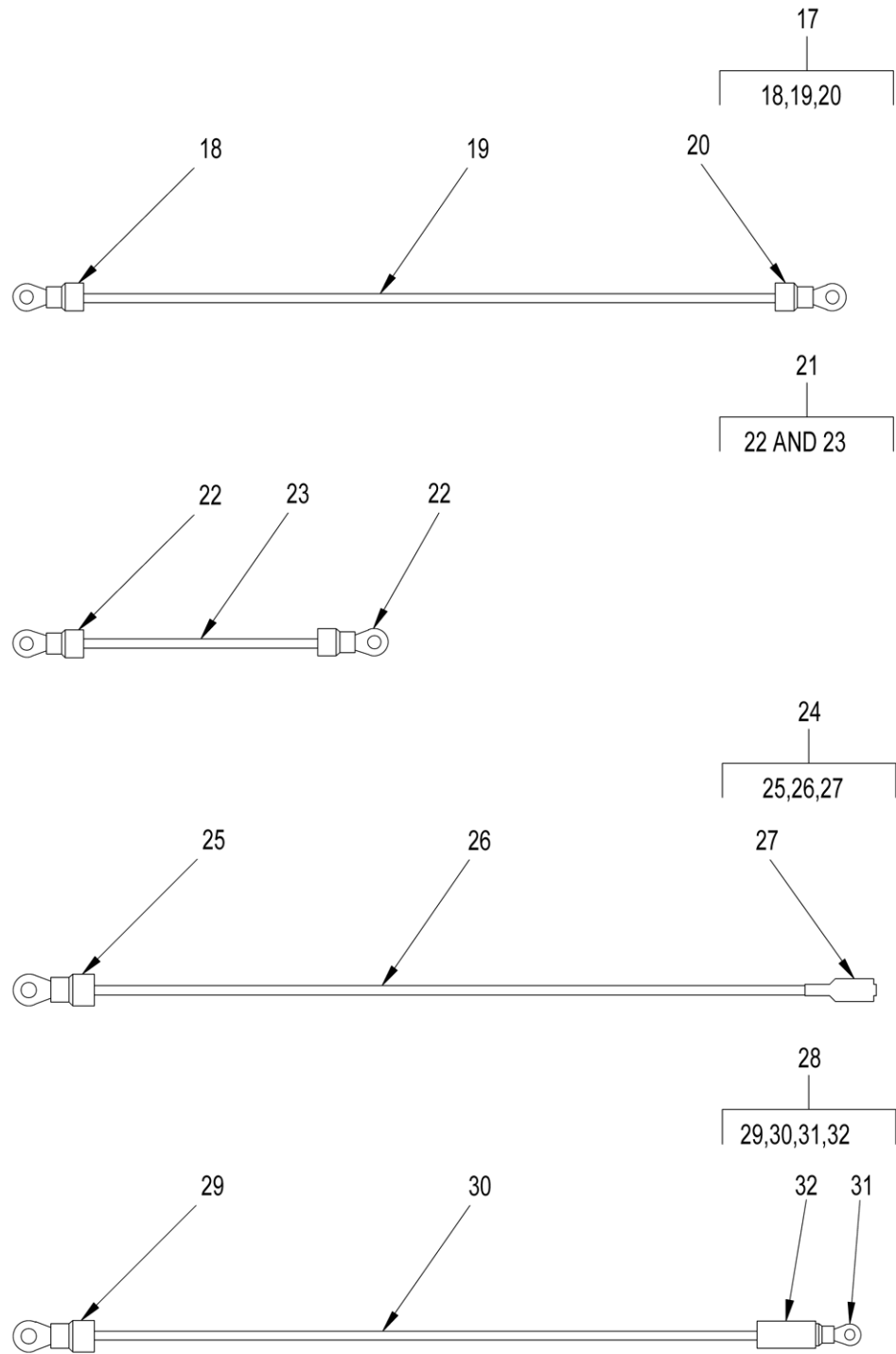

Figure 29. Control Panel Electrical Leads (MEP-531A) (Sheet 2 of 5).

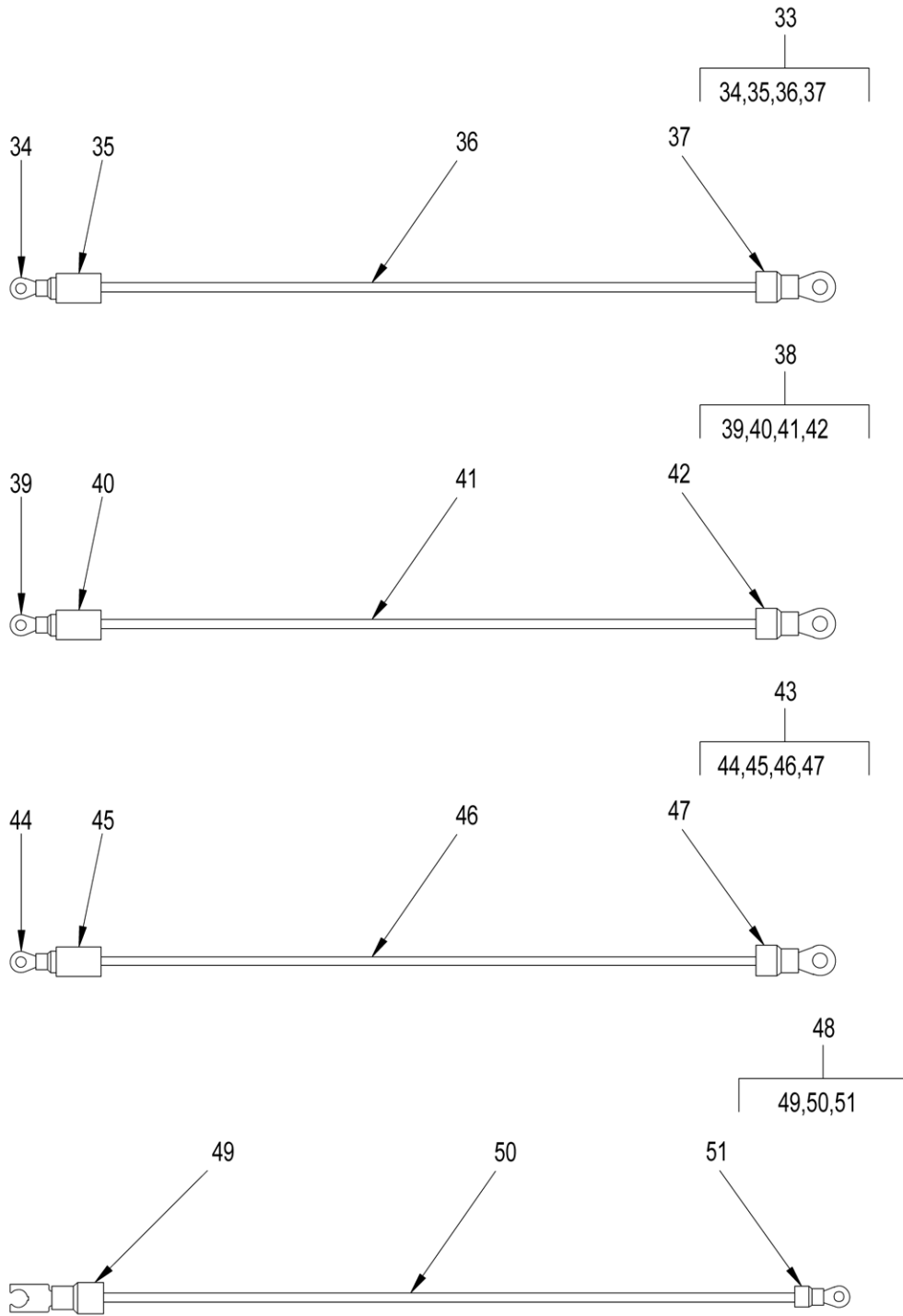

Figure 29. Control Panel Electrical Leads (MEP-531A) (Sheet 3 of 5).

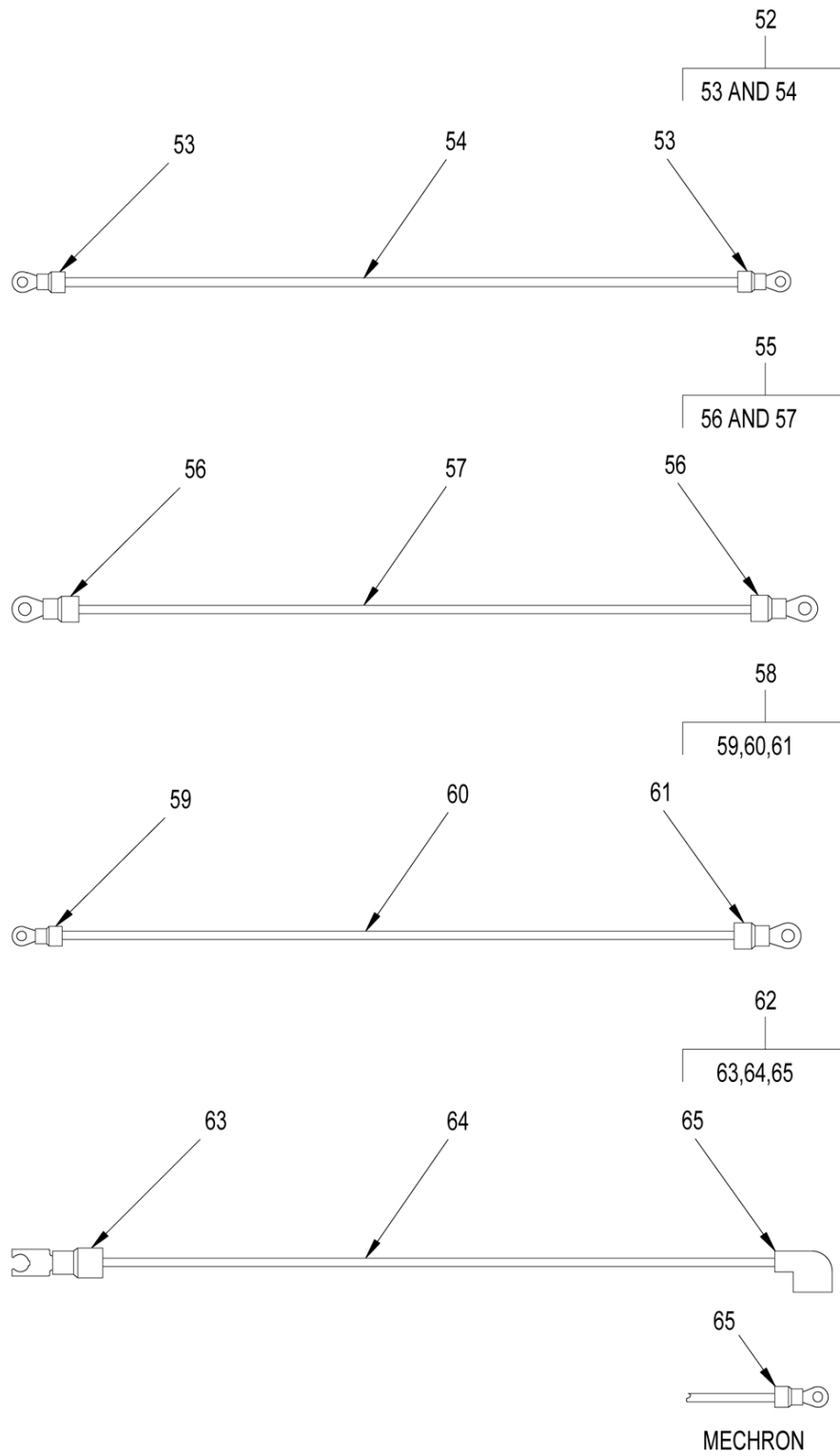

Figure 29. Control Panel Electrical Leads (MEP-531A) (Sheet 4 of 5).

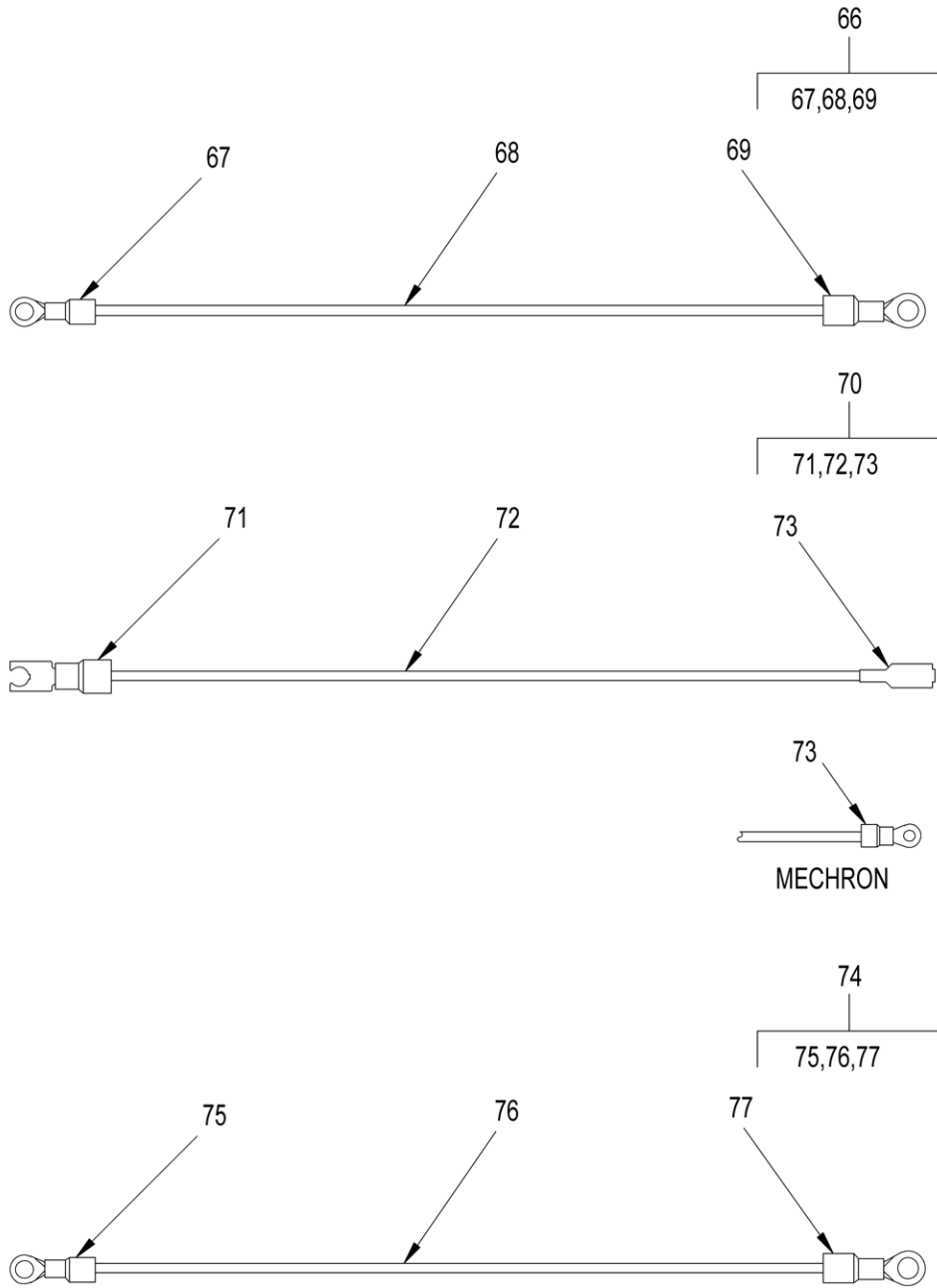

Figure 29. Control Panel Electrical Leads (MEP-531A) (Sheet 5 of 5).

(1)	(2)		(3)	(4)	(5)	(6)	(7)
ITEM NO	SMR CODE		NSN	CAGEC	PART NUMBER	DESCRIPTION AND USABLE ON CODE (UOC)	QTY
	a. ARMY	b. AIR FORCE					
GROUP 0412 CONTROL PANEL ELECTRICAL LEADS (MEP-531A)							
FIG. 29 CONTROL PANEL ELECTRICAL LEADS (MEP-531A)							
1	AOFFF	AOOOO		30554	95-8166-1	. LEAD, ELECTRICAL (NOT SHOWN)..	1
2	PAFZZ	PAOZZ	5940-00-143-4780	98410	BB-837-10	.. TERMINAL, LUG	1
3	MOFZZ	MOOZZ		30554	95-8166-1-11	.. WIRE, ELECTRICAL 16 MAKE FROM M16878/3BJE-9, WP 0153, BULK, ITEM 9, 12-1/4 IN. REQUIRED	1
4	PAFZZ	PAOZZ	5940-01-356-6456	00779	640919-1	.. TERMINAL, QUICK DISC	1
5	AOFFF	AOOOO		30554	95-8166-2	. LEAD, ELECTRICAL (NOT SHOWN)..	1
6	PAFZZ	PAOZZ	5940-01-356-6456	00779	640919-1	.. TERMINAL, QUICK DISC	1
7	MOFZZ	MOOZZ		30554	95-8166-2-11	.. WIRE, ELECTRICAL 16 MAKE FROM M16878/3BJE-9, WP 0153, BULK, ITEM 9, 11-1/2 IN. REQUIRED	1
8	PAFZZ	PAOZZ	5940-00-143-4780	98410	BB-837-10	.. TERMINAL, LUG	1
9	AOFFF	AOOOO		30554	95-8166-3	. LEAD, ELECTRICAL (NOT SHOWN)....	1
10	PAFZZ	PAOZZ	5940-00-143-4780	98410	BB-837-10	.. TERMINAL, LUG	2
11	MOFZZ	MOOZZ		30554	95-8166-3-11.	.. WIRE, ELECTRICAL 16 MAKE FROM M16878/3BJE-9, WP 0153, BULK, ITEM 9, 2-3/4 IN. REQUIRED	1
12	AOFFF	AOOOO		30554	95-8166-4	. LEAD, ELECTRICAL (NOT SHOWN)..	1
13	PAFZZ	PAOZZ		06383	P14-6R	.. TERMINAL, LUG	1
14	MOFZZ	MOOZZ		30554	95-8166-4-13	.. SLEEVING, INSULATION MAKE FROM ST-301-3/16 BLACK, WP 0153, BULK, ITEM 12, 1 IN. REQUIRED	1
15	MOFZZ	MOOZZ		30554	95-8166-4-11	.. WIRE, ELECTRICAL 16 MAKE FROM M16878/3BJE-9, WP 0153, BULK, ITEM 9, 23-1/2 IN. REQUIRED	1
16	PAFZZ	PAOZZ	5940-01-082-3321	15912	RB2573	.. TERMINAL, QUICK DISC.	1
17	AOFFF	AOOOO		30554	95-8166-5	. LEAD, ELECTRICAL (NOT SHOWN)..	1
18	PAFZZ	PAOZZ	5940-00-143-4780	98410	BB-837-10	.. TERMINAL, LUG	1
19	MOFZZ	MOOZZ		30554	95-8166-5-11	.. WIRE, ELECTRICAL 16 MAKE FROM M16878/3BJE-9, WP 0153, BULK, ITEM 9, 22-1/2 IN. REQUIRED	1
20	PAFZZ	PAOZZ	5940-00-230-0515	98410	BB-825-14	.. TERMINAL, LUG	1
21	AOFFF	AOOOO		30554	95-8166-6	. LEAD, ELECTRICAL (NOT SHOWN)..	1
22	PAFZZ	PAOZZ	5940-00-143-4780	98410	BB-837-10	.. TERMINAL, LUG	2
23	MOFZZ	MOOZZ		30554	95-8166-6-11	.. WIRE, ELECTRICAL 16 MAKE FROM M16878/3BJE-9, WP 0153, BULK, ITEM 9, 2-3/4 IN. REQUIRED	1
24	AOFFF	AOOOO		30554	95-8166-7	. LEAD, ELECTRICAL (NOT SHOWN)..	1
25	PAFZZ	PAOZZ	5940-00-230-0515	98410	BB-825-14	.. TERMINAL, LUG	1
26	MOFZZ	MOOZZ		30554	95-8166-7-11	.. WIRE, ELECTRICAL 16 MAKE FROM M16878/3BJE-9, WP 0153, BULK, ITEM 9, 29 IN. REQUIRED.....	1
27	PAFZZ	PAOZZ	5940-01-082-3321	15912	RB2573	.. TERMINAL, QUICK DISC.	1
28	AOFFF	AOOOO		30554	95-8166-8	. LEAD, ELECTRICAL (NOT SHOWN)..	1
29	PAFZZ	PAOZZ	5940-00-230-0515	98410	BB-825-14	.. TERMINAL, LUG	1

(1)	(2)		(3)	(4)	(5)	(6)	(7)
ITEM NO	SMR CODE		NSN	CAGEC	PART NUMBER	DESCRIPTION AND USABLE ON CODE (UOC)	QTY
	a. ARMY	b. AIR FORCE					
30	MOFZZ	MOOZZ		30554	95-8166-8-11	. . WIRE, ELECTRICAL 16 MAKE FROM M16878/3BJE-9, WP 0153, BULK, ITEM 9, 9-3/4 IN. REQUIRED	1
31	PAFZZ	PAOZZ	5940-00-243-0409	06383	P14-6R	. . TERMINAL, LUG	1
32	MOFZZ	MOOZZ		30554	95-8166-8-13	. . SLEEVING, INSULATION MAKE FROM ST-301-3/16 BLACK, WP 0153, BULK, ITEM 12, 1 IN. REQUIRED	1
33	AOFFF	AOOOO		30554	95-8166-9	. LEAD, ELECTRICAL (NOT SHOWN).	1
34	PAFZZ	PAOZZ	5940-00-243-0409	06383	P14-6R	. . TERMINAL, LUG	1
35	MOFZZ	MOOZZ		30554	95-8166-9-13	. . SLEEVING, INSULATION MAKE FROM ST-301-3/16 BLACK, WP 0153, BULK, ITEM 12, 1 IN. REQUIRED	1
36	MOFZZ	MOOZZ		30554	95-8166-9-11	. . WIRE, ELECTRICAL 16 MAKE FROM M16878/3BJE-9, WP 0153, BULK, ITEM 9, 8-3/4 IN. REQUIRED	1
37	PAFZZ	PAOZZ	5940-00-143-4780	98410	BB-837-10	. . TERMINAL, LUG	1
38	AOFFF	AOOOO		30554	95-8166-10	. LEAD, ELECTRICAL (NOT SHOWN)..	1
39	PAFZZ	PAOZZ	5940-00-243-0409	06383	P14-6R	. . TERMINAL, LUG	1
40	MOFZZ	MOOZZ		30554	95-8166-10-13	. . SLEEVING, INSULATION MAKE FROM ST-301-3/16 BLACK, WP 0153, BULK, ITEM 12, 1 IN. REQUIRED	1
41	MOFZZ	MOOZZ		30554	95-8166-10-12	. . WIRE, ELECTRICAL 14 MAKE FROM M16878/3BKE-9, WP 0153, BULK, ITEM 13, 31-1/2 IN. REQUIRED	1
42	PAFZZ	PAOZZ	5940-00-143-4780	98410	BB-837-10	. . TERMINAL, LUG	1
43	AOFFF	AOOOO		30554	95-8166-11	. LEAD, ELECTRICAL (NOT SHOWN)..	1
44	PAFZZ	PAOZZ	5940-00-243-0409	06383	P14-6R	. . TERMINAL, LUG	1
45	MOFZZ	MOOZZ		30554	95-8166-11-13	. . SLEEVING, INSULATION MAKE FROM ST-301-3/16 BLACK, WP 0153, BULK, ITEM 12, 1 IN. REQUIRED	1
46	MOFZZ	MOOZZ		30554	95-8166-11-12	. . WIRE, ELECTRICAL 14 MAKE FROM M16878/3BKE-9, WP 0153, BULK, ITEM 13, 12-3/4 IN. REQUIRED	1
47	PAFZZ	PAOZZ	5940-00-230-0515	98410	BB-825-14	. . TERMINAL, LUG	1
48	AOFFF	AOOOO		30554	95-8166-12	. LEAD, ELECTRICAL(NOT SHOWN)..	1
49	PAFZZ	PAOZZ	5940-01-259-2190	98410	BB-8194-08	. . TERMINAL, LUG	1
50	MOFZZ	MOOZZ		30554	95-8166-12-12	. . WIRE ELECTRICAL 14 MAKE FROM M16878/3BKE-9, WP 0153, BULK, ITEM 13, 21 IN. REQUIRED	1
51	PAFZZ	PAOZZ	5940-00-230-0515	98410	BB-825-14	. . TERMINAL, LUG	1
52	AOFFF	AOOOO		30554	95-8166-13	. LEAD, ELECTRICAL(NOT SHOWN)..	1
53	PAFZZ	PAOZZ	5940-00-230-0515	98410	BB-825-14	. . TERMINAL, LUG	2
54	MOFZZ	MOOZZ		30554	95-8166-13-12	. . WIRE, ELECTRICAL 14 MAKE FROM M16878/3BKE-9, WP 0153, BULK, ITEM 13, 11-1/2 IN. REQUIRED	1
55	AOFFF	AOOOO		30554	95-8166-14	. LEAD, ELECTRICAL(NOT SHOWN)...	1
56	PAFZZ	PAOZZ	5940-00-143-4780	98410	BB-837-10	. . TERMINAL, LUG	2
57	MOFZZ	MOOZZ		30554	95-8166-14-12	. . WIRE, ELECTRICAL 14 MAKE FROM M16878/3BKE-9, WP 0153, BULK, ITEM 13, 32-3/4 IN. REQUIRED	1
58	AOFFF	AOOOO		30554	95-8166-15	. LEAD, ELECTRICAL(NOT SHOWN)...	1
59	PAFZZ	PAOZZ	5940-00-143-4780	98410	BB-837-10	. . TERMINAL, LUG	1
60	MOFZZ	MOOZZ		30554	95-8166-15-12	. . WIRE, ELECTRICAL 14 MAKE FROM M16878/3BKE-9, WP 0153, BULK, ITEM 13, 15 IN. REQUIRED	1
61	PAFZZ	PAOZZ	5940-00-230-0515	98410	BB-825-14	. . TERMINAL, LUG	1

(1)	(2)		(3)	(4)	(5)	(6)	(7)
ITEM NO	SMR CODE		NSN	CAGEC	PART NUMBER	DESCRIPTION AND USABLE ON CODE (UOC)	QTY
	a. ARMY	b. AIR FORCE					
62	AOFFF	AOOOO		30554	95-8166-16	. LEAD, ELECTRICAL(NOT SHOWN)...	1
63	PAFZZ	PAOZZ	5940-01-259-2190	98410	BB-8194-08	. . TERMINAL, LUG	1
64	MOFZZ	MOOZZ		30554	95-8166-16-12	. . WIRE, ELECTRICAL 14 MAKE FROM M16878/3BKE-9, WP 0153, BULK, ITEM 13, 21-1/2 IN. REQUIRED	1
65	PAFZZ	PAOZZ	5940-00-230-0515	98410	BB-825-14	. . TERMINAL, LUG (MECHRON 120 VAC)	1
65	PAFZZ	PAOZZ	5940-01-068-1879	56501	RB-2577F	. . TERMINAL, QUICK DISC FEM 90° (MEP-531A)	1
66	AOFFF	AOOOO		30554	95-8166-17	. LEAD, ELECTRICAL (NOT SHOWN)..	1
67	PAFZZ	PAOZZ	5940-01-465-3185	06383	PV8-10R-Q	. . TERMINAL, LUG	1
68	MOFZZ	MOOZZ		30554	95-8166-17-5	. . WIRE, ELECTRICAL 8 MAKE FROM M16878/3BNL-9, WP 0153, BULK, ITEM 10, 8 IN. REQUIRED	1
69	PAFZZ	PAOZZ	5940-01-465-4413	06383	PV8-38R-Q	. . TERMINAL, LUG	1
70	AOFFF	AOOOO		30554	95-8166-18	. LEAD, ELECTRICAL(NOT SHOWN)...	1
71	PAFZZ	PAOZZ	5940-01-259-2190	98410	BB-8194-08	. . TERMINAL, LUG	1
72	MOFZZ	MOOZZ		30554	95-8166-18-12	. . WIRE, ELECTRICAL 14 MAKE FROM M16878/3BKE-9 WP 0153, BULK, ITEM 13, 18-1/2 IN. REQUIRED.....	1
73	PAFZZ	PAOZZ	5940-01-082-3321	15912	RB2573	. . TERMINAL, QUICK DISC (MEP-531A)	1
73	PAFZZ	PAOZZ		98410	BB-825-14	. . TERMINAL, LUG (MECHRON 120 VAC)	1
74	AOFFF	AOOOO		30554	95-8166-19	. LEAD, ELECTRICAL(NOT SHOWN)...	1
75	PAFZZ	PAOZZ	5940-00-143-5284	96906	MS25036-115	. . TERMINAL, LUG	1
76	MOFZZ	MOOZZ		30554	95-8166-19-5	. . WIRE, ELECTRICAL 8 MAKE FROM M16878/3BNL-9, WP 0153, BULK, ITEM 10, 5 IN. REQUIRED	1
77	PAFZZ	PAOZZ	5940-01-465-4413	06383	PV8-38R-Q	. . TERMINAL, LUG	1

END OF FIGURE

OPERATOR AND FIELD MAINTENANCE

2 kW MEP-501A/531A MILITARY TACTICAL GENERATOR SETS
 GROUP 0412 CONTROL PANEL ELECTRICAL LEADS (MEP-501A)

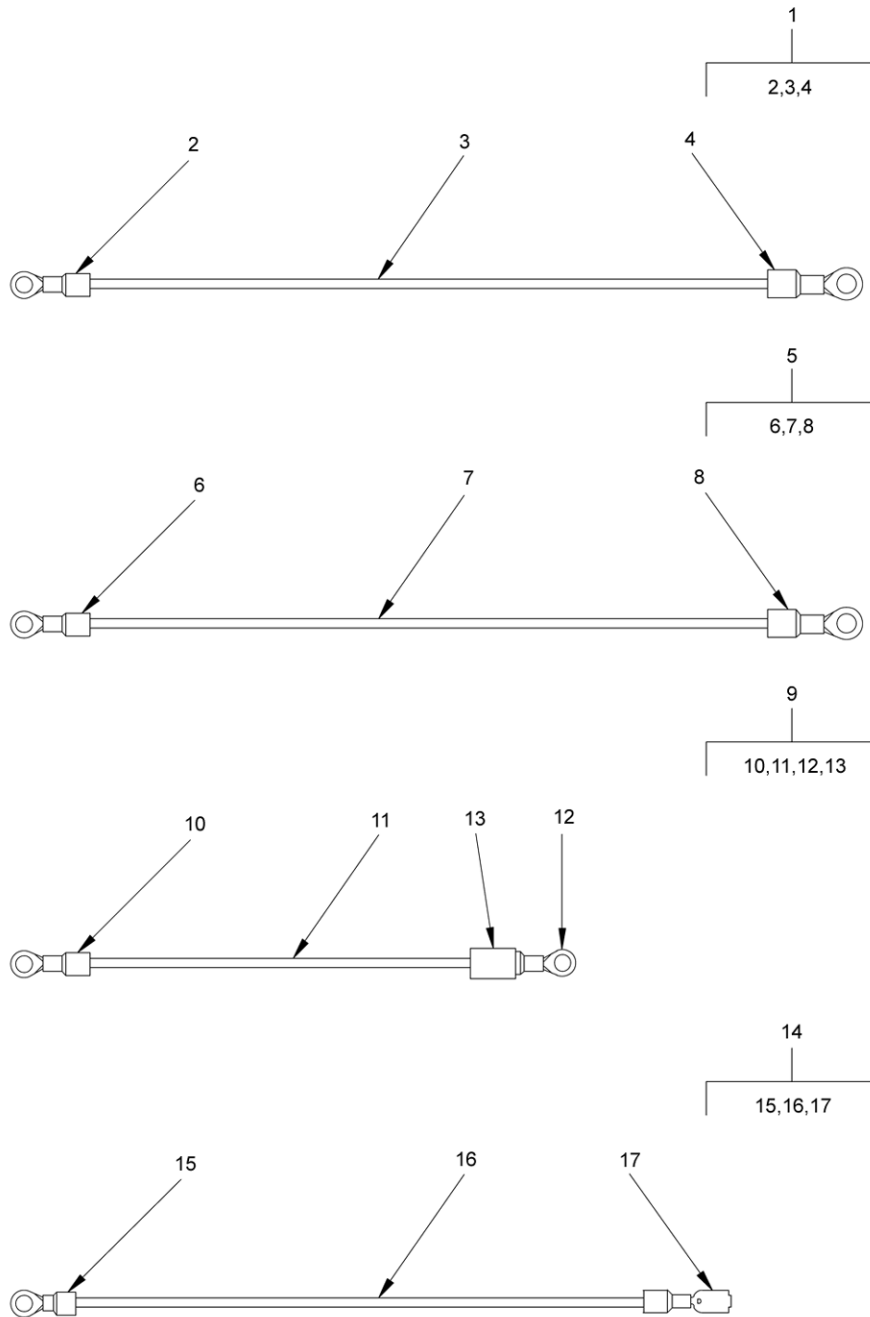

Figure 30. Control Panel Electrical Leads (MEP-501A) (Sheet 1 of 6).

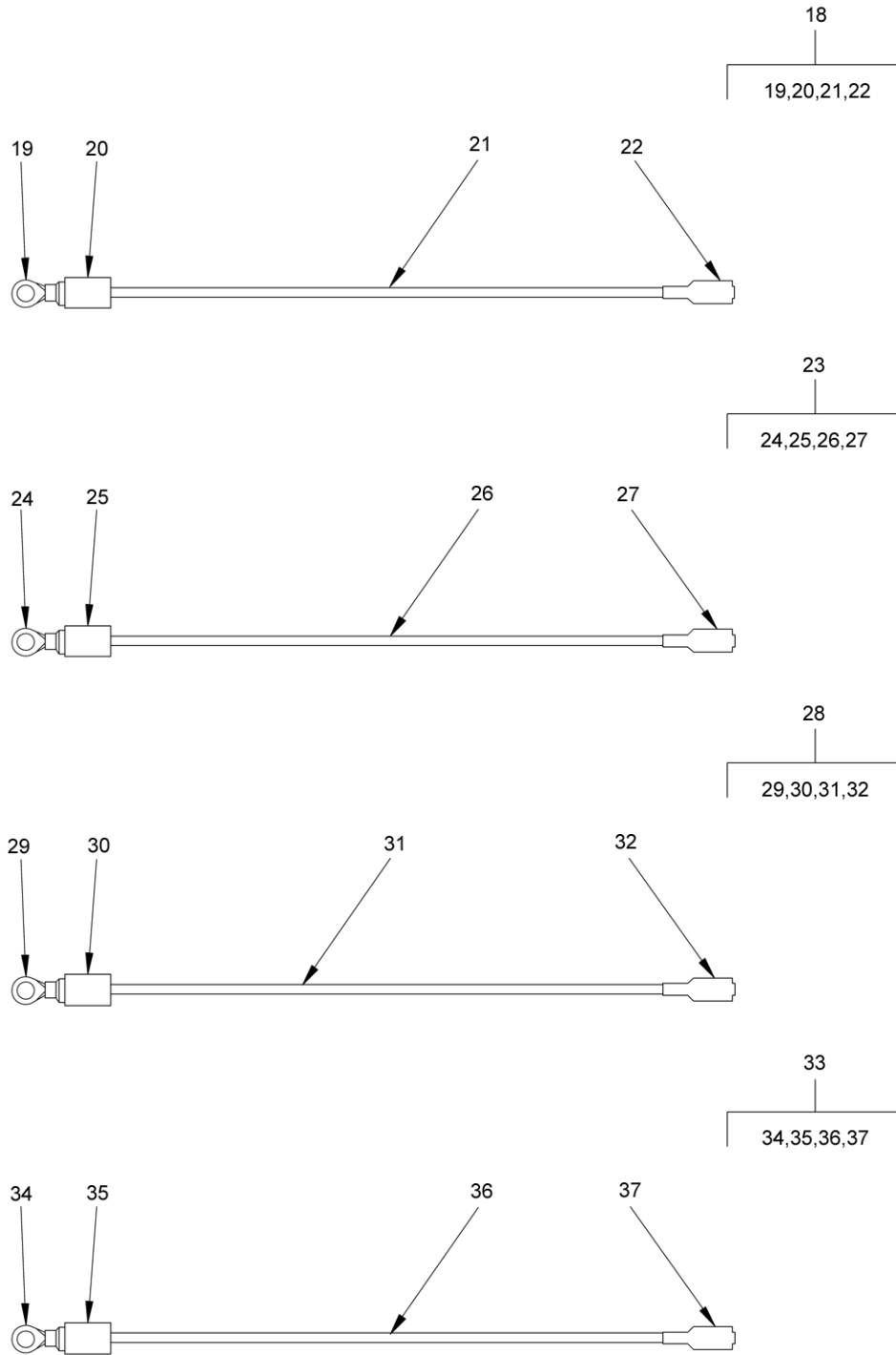

Figure 30. Control Panel Electrical Leads (MEP-501A) (Sheet 2 of 6).

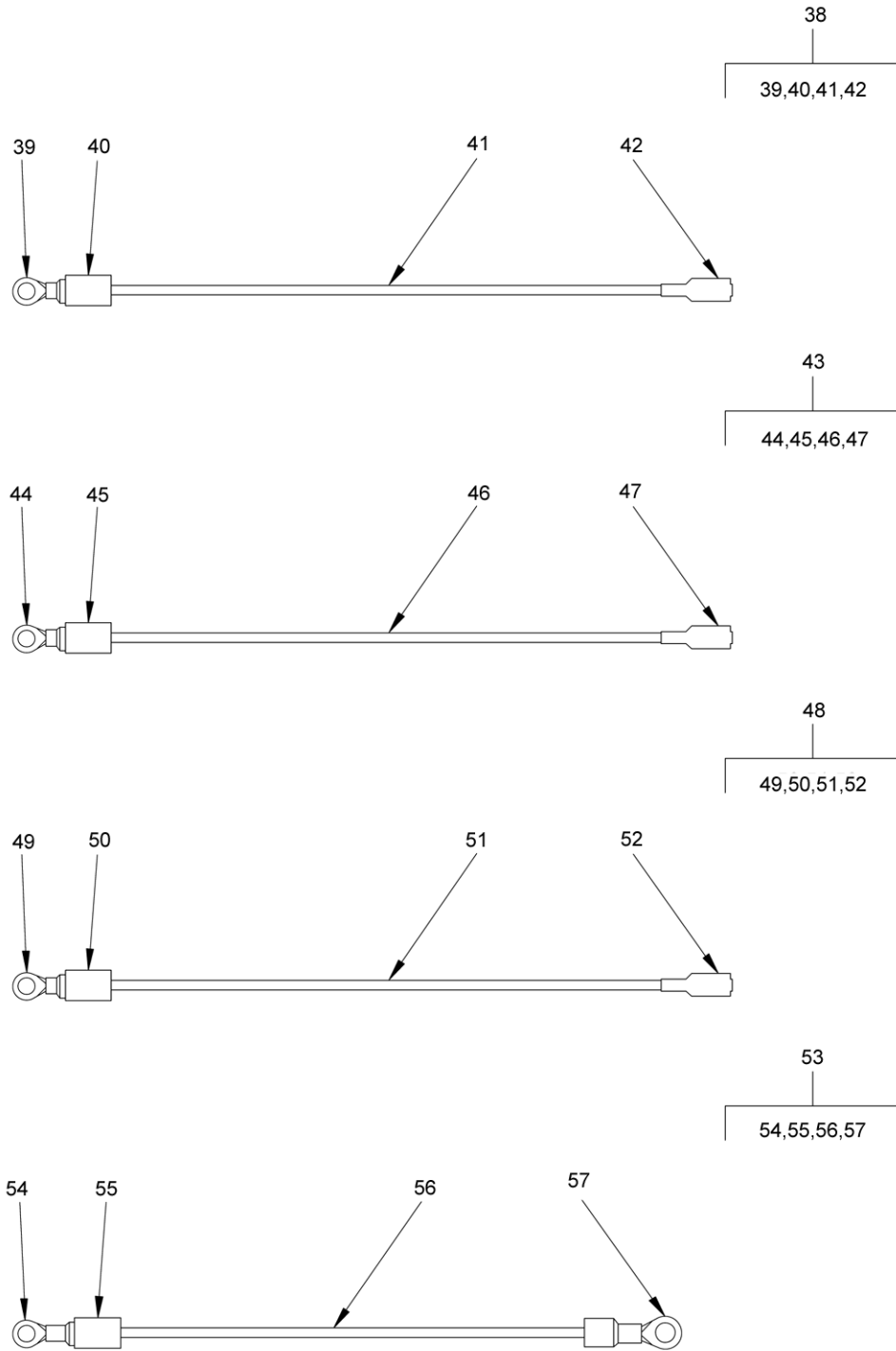

Figure 30. Control Panel Electrical Leads (MEP-501A) (Sheet 3 of 6).

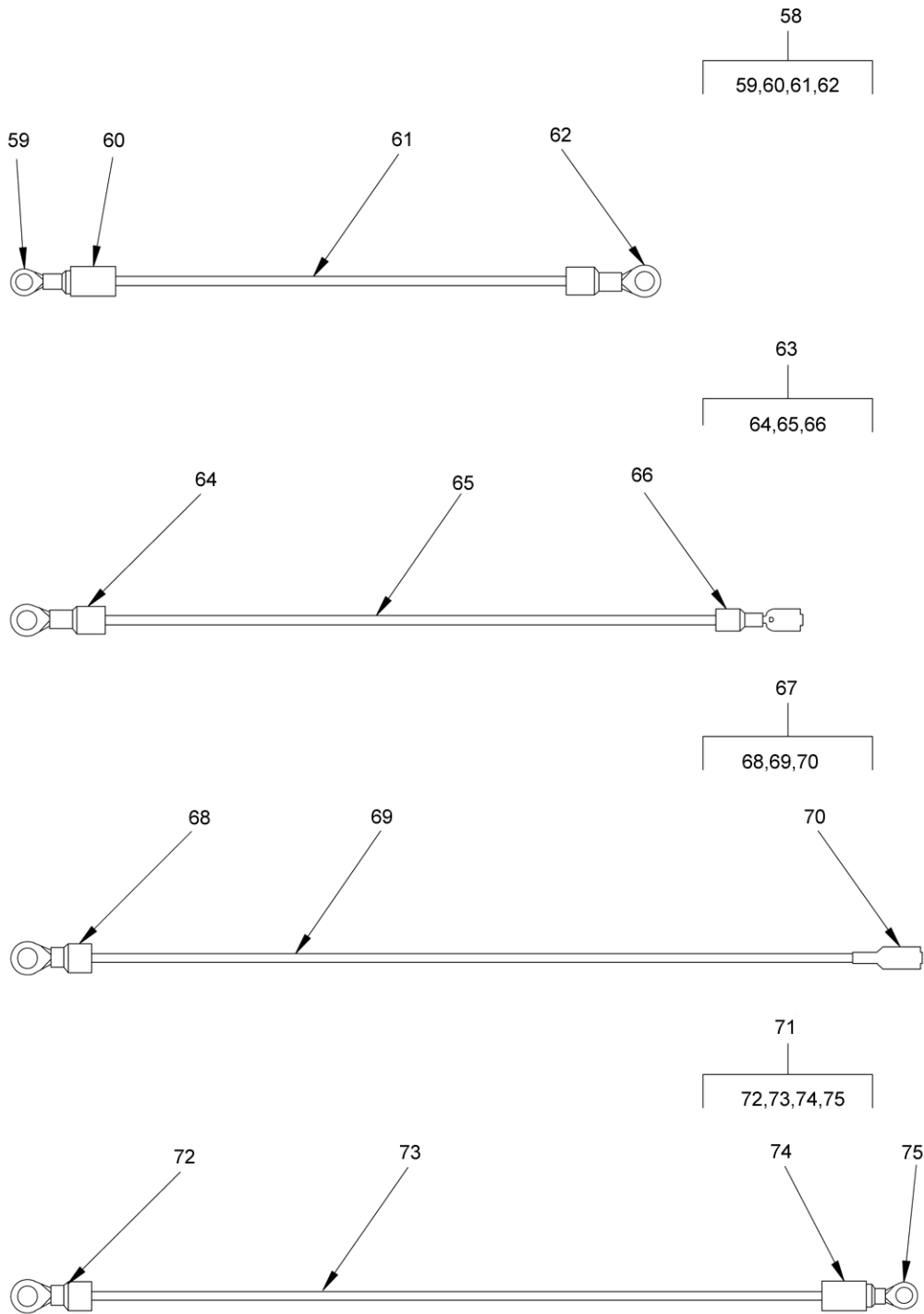

Figure 30. Control Panel Electrical Leads (MEP-501A) (Sheet 4 of 6).

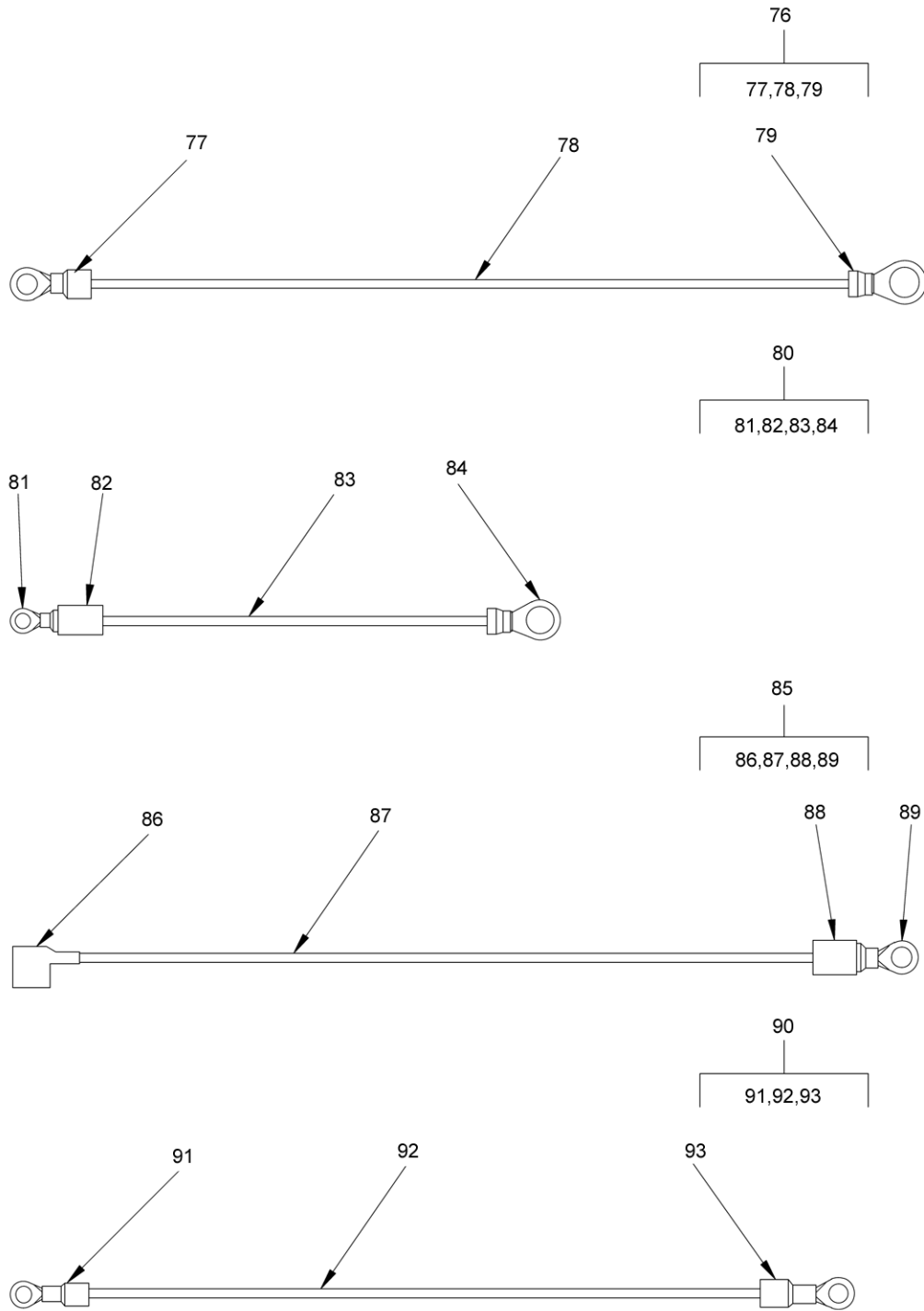

Figure 30. Control Panel Electrical Leads (MEP-501A) (Sheet 5 of 6).

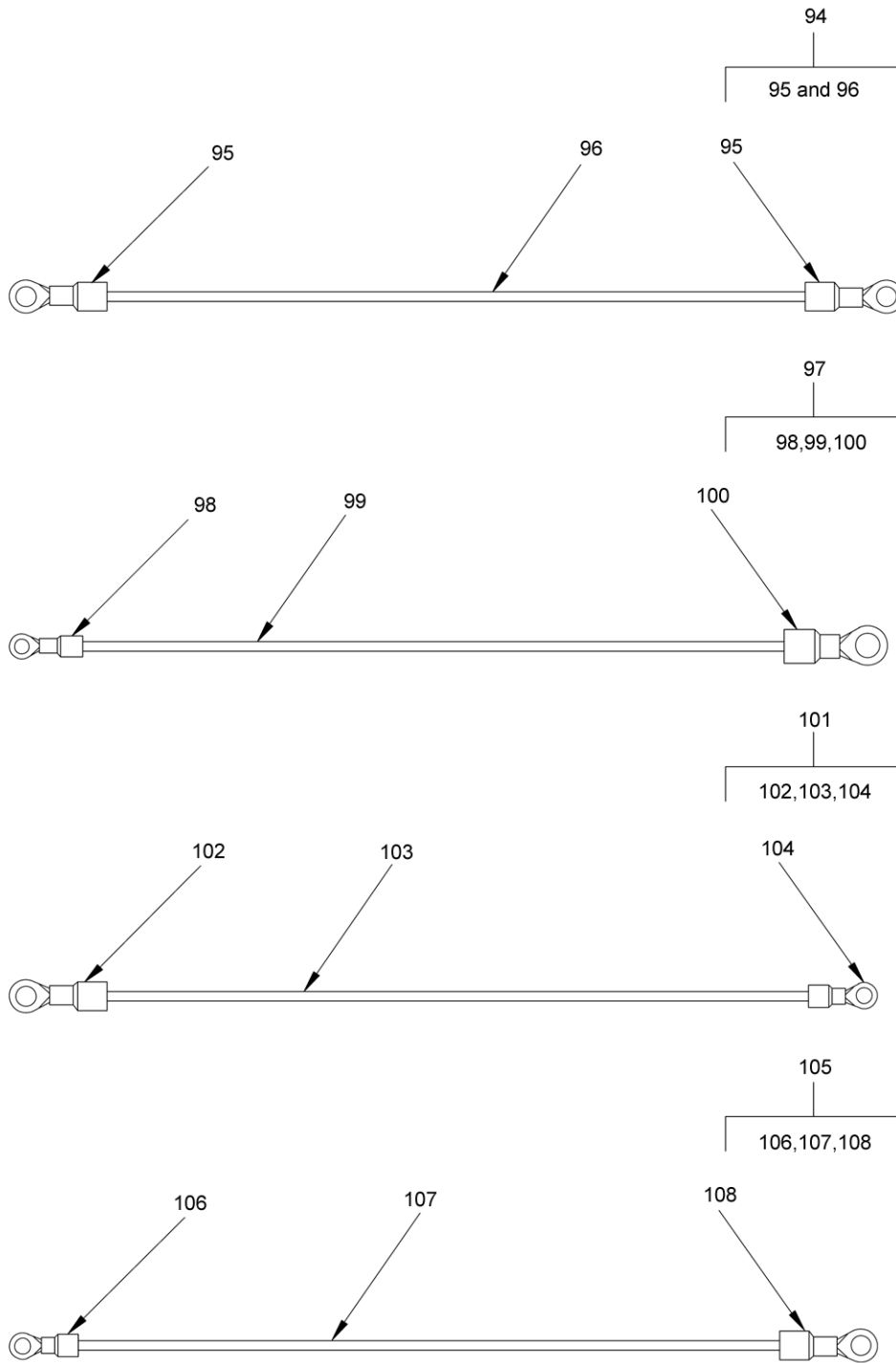

Figure 30. Control Panel Electrical Leads (MEP-501A) (Sheet 6 of 6).

(1)	(2)		(3)	(4)	(5)	(6)	(7)
ITEM NO	SMR CODE		NSN	CAGEC	PART NUMBER	DESCRIPTION AND USABLE ON CODE (UOC)	QTY
	a. ARMY	b. AIR FORCE					
GROUP 0412 CONTROL PANEL ELECTRICAL LEADS (MEP-501A)							
FIG. 30 CONTROL PANEL ELECTRICAL LEADS (MEP-501A)							
1	AOFFF	AOOOO		30554	95-8056-1	. LEAD, ELECTRICAL(NOT SHOWN)...	1
2	PAFZZ	PAOZZ	5940-00-143-4774	96906	MS25036-153	.. TERMINAL, LUG	1
3	MOFZZ	MOOZZ		30554	95-8056-1-13	.. WIRE, ELECTRICAL 16 MAKE FROM M16878/3BJE-9, WP 0153, BULK, ITEM 9, 23-3/4 IN. REQUIRED	1
4	PAFZZ	PAOZZ	5940-00-143-4780	98410	BB-837-10	.. TERMINAL, LUG	1
5	AOFFF	AOOOO		30554	95-8056-2	. LEAD, ELECTRICAL(NOT SHOWN)...	1
6	PAFZZ	PAOZZ	5940-00-143-4774	96906	MS25036-153	.. TERMINAL, LUG	1
7	MOFZZ	MOOZZ		30554	95-8056-2-13	.. WIRE, ELECTRICAL 16 MAKE FROM M16878/3BJE-9, WP 0153, BULK, ITEM 9, 27-1/2 IN. REQUIRED	1
8	PAFZZ	PAOZZ	5940-00-143-4780	98410	BB-837-10	.. TERMINAL, LUG	1
9	AOFFF	AOOOO		30554	95-8056-3	. LEAD, ELECTRICAL(NOT SHOWN)..	1
10	PAFZZ	PAOZZ	5940-00-143-4774	96906	MS25036-153	.. TERMINAL, LUG	1
11	MOFZZ	MOOZZ		30554	95-8056-3-13	.. WIRE, ELECTRICAL 16 MAKE FROM M16878/3BJE-9, WP 0153, BULK, ITEM 9, 5 IN. REQUIRED	1
12	PAFZZ	PAOZZ	5940-00-243-0409	06383	P14-6R	.. TERMINAL, LUG	1
13	MOFZZ	MOOZZ		30554	95-8056-3-16	.. SLEEVING, INSULATION MAKE FROM ST-301-3/16 BLACK, WP 0153, BULK, ITEM 12, 1 IN. REQUIRED	1
14	AOFFF	AOOOO		30554	95-8056-4	. LEAD, ELECTRICAL(NOT SHOWN)...	1
15	PAFZZ	PAOZZ	5940-00-143-4780	98410	BB-837-10	.. TERMINAL, LUG	1
16	MOFZZ	MOOZZ		30554	95-8056-4-13	.. WIRE, ELECTRICAL 16 MAKE FROM M16878/3BJE-9, WP 0153, BULK, ITEM 9, 9 IN. REQUIRED	1
17	PAFZZ	PAOZZ	5940-01-356-6456	00779	640919-1	.. TERMINAL, QUICK DISC.	1
18	AOFFF	AOOOO		30554	95-8056-5	. LEAD, ELECTRICAL(NOT SHOWN)....	1
19	PAFZZ	PAOZZ	5940-00-243-0409	06383	P14-6R	.. TERMINAL, LUG	1
20	MOFZZ	MOOZZ		30554	95-8056-5-16	.. SLEEVING, INSULATION MAKE FROM ST-301-3/16 BLACK, WP 0153, BULK, ITEM 12, 1 IN. REQUIRED	1
21	MOFZZ	MOOZZ		30554	95-8056-5-13	.. WIRE, ELECTRICAL 16 MAKE FROM M16878/3BJE-9, WP 0153, BULK, ITEM 9, 14-1/2 IN. REQUIRED	1
22	PAFZZ	PAOZZ	5940-01-082-3321	15912	RB2573	.. TERMINAL, QUICK DISC	1
23	AOFFF	AOOOO		30554	95-8056-6	. LEAD, ELECTRICAL(NOT SHOWN)....	1
24	PAFZZ	PAOZZ	5940-00-243-0409	06383	P14-6R	.. TERMINAL, LUG	1
25	MOFZZ	MOOZZ		30554	95-8056-6-16	.. SLEEVING, INSULATION MAKE FROM ST-301-3/16 BLACK, WP 0153, BULK, ITEM 12, 1 IN. REQUIRED	1
26	MOFZZ	MOOZZ		30554	95-8056-6-13	.. WIRE, ELECTRICAL 16 MAKE FROM M16878/3BJE-9, WP 0153, BULK, ITEM 9, 13-7/8 IN. REQUIRED	1
27	PAFZZ	PAOZZ	5940-01-082-3321	15912	RB2573	.. TERMINAL, QUICK DISC.	1
28	AOFFF	AOOOO		30554	95-8056-7	. LEAD, ELECTRICAL (NOT SHOWN)....	1

(1)	(2)		(3)	(4)	(5)	(6)	(7)
ITEM NO	SMR CODE		NSN	CAGEC	PART NUMBER	DESCRIPTION AND USABLE ON CODE (UOC)	QTY
	a. ARMY	b. AIR FORCE					
29	PAFZZ	PAOZZ	5940-00-243-0409	06383	P14-6R	.. TERMINAL, LUG	1
30	MOFZZ	MOOZZ		30554	95-8056-7-16	.. SLEEVING, INSULATION MAKE FROM ST-301-3/16 BLACK, WP 0153, BULK, ITEM 12, 1 IN. REQUIRED	1
31	MOFZZ	MOOZZ		30554	95-8056-7-13	.. WIRE, ELECTRICAL 16 MAKE FROM M16878/3BJE-9, WP 0153, BULK, ITEM 9, 13-5/8 IN. REQUIRED	1
32	PAFZZ	PAOZZ	5940-01-082-3321	15912	RB2573	.. TERMINAL, QUICK DISC.	1
33	AOFFF	AOOOO		30554	95-8056-8	. LEAD, ELECTRICAL(NOT SHOWN).....	1
34	PAFZZ	PAOZZ	5940-00-243-0409	06383	P14-6R	.. TERMINAL, LUG	1
35	MOFZZ	MOOZZ		30554	95-8056-8-16	.. SLEEVING, INSULATION MAKE FROM ST-301-3/16 BLACK, WP 0153, BULK, ITEM 12, 1 IN. REQUIRED	1
36	MOFZZ	MOOZZ		30554	95-8056-8-13	.. WIRE, ELECTRICAL 16 MAKE FROM M16878/3BJE-9, WP 0153, BULK, ITEM 9, 13-1/2 IN. REQUIRED	1
37	PAFZZ	PAOZZ	5940-01-082-3321	15912	RB2573	.. TERMINAL, QUICK DISC.	1
38	AOFFF	AOOOO		30554	95-8056-9	. LEAD, ELECTRICAL(NOT SHOWN).....	1
39	PAFZZ	PAOZZ	5940-00-243-0409	06383	P14-6R	.. TERMINAL, LUG	1
40	MOFZZ	MOOZZ		30554	95-8056-9-16	.. SLEEVING, INSULATION MAKE FROM ST-301-3/16 BLACK, WP 0153, BULK, ITEM 12, 1 IN. REQUIRED	1
41	MOFZZ	MOOZZ		30554	95-8056-9-13	. WIRE, ELECTRICAL 16 MAKE FROM M16878/3BJE-9, WP 0153, BULK, ITEM 9, 14 IN. REQUIRED.....	1
42	PAFZZ	PAOZZ	5940-01-082-3321	15912	RB2573	.. TERMINAL, QUICK DISC	1
43	AOFFF	AOOOO		30554	95-8056-10	. LEAD, ELECTRICAL(NOT SHOWN).....	1
44	PAFZZ	PAOZZ	5940-00-243-0409	06383	P14-6R	.. TERMINAL, LUG	1
45	MOFZZ	MOOZZ		30554	95-8056-10-16	.. SLEEVING, INSULATION MAKE FROM ST-301-3/16 BLACK, WP 0153, BULK, ITEM 12, 1 IN. REQUIRED	1
46	MOFZZ	MOOZZ		30554	95-8056-10-13	.. WIRE, ELECTRICAL 16 MAKE FROM M16878/3BJE-9 WP 0153, BULK, ITEM 9, 13-5/8 IN. REQUIRED	1
47	PAFZZ	PAOZZ	5940-01-082-3321	15912	RB2573	.. TERMINAL, QUICK DISC.	1
48	AOFFF	AOOOO		30554	95-8056-11	. LEAD, ELECTRICAL(NOT SHOWN).....	1
49	PAFZZ	PAOZZ	5940-00-243-0409	06383	P14-6R	.. TERMINAL, LUG	1
50	MOFZZ	MOOZZ		30554	95-8056-11-16	.. SLEEVING, INSULATION MAKE FROM ST-301-3/16 BLACK, WP 0153, BULK, ITEM 12, 1 IN. REQUIRED	1
51	MOFZZ	MOOZZ		30554	95-8056-11-13	.. WIRE, ELECTRICAL 16 MAKE FROM M16878/3BJE-9, WP 0153, BULK, ITEM 9, 20-3/4 IN. REQUIRED	1
52	PAFZZ	PAOZZ	5940-01-082-3321	15912	RB2573	.. TERMINAL, QUICK DISC	1
53	AOFFF	AOOOO		30554	95-8056-12	. LEAD, ELECTRICAL (NOT SHOWN).....	1
54	PAFZZ	PAOZZ	5940-00-243-0409	06383	P14-6R	.. TERMINAL, LUG	1
55	MOFZZ	MOOZZ		30554	95-8056-12-16	.. SLEEVING, INSULATION MAKE FROM ST-301-3/16 BLACK, WP 0153, BULK, ITEM 12, 1 IN. REQUIRED	1
56	MOFZZ	MOOZZ		30554	95-8056-12-13	.. WIRE, ELECTRICAL 16 MAKE FROM M16878/3BJE-9, WP 0153, BULK, ITEM 9, 8 IN. REQUIRED	1
57	PAFZZ	PAOZZ	5940-00-143-4780	98410	BB-837-10	.. TERMINAL, LUG	1
58	AOFFF	AOOOO		30554	95-8056-13	. LEAD, ELECTRICAL(NOT SHOWN).....	1
59	PAFZZ	PAOZZ	5940-00-243-0409	06383	P14-6R	.. TERMINAL, LUG	1

(1)	(2)		(3)	(4)	(5)	(6)	(7)
ITEM NO	SMR CODE		NSN	CAGEC	PART NUMBER	DESCRIPTION AND USABLE ON CODE (UOC)	QTY
	a. ARMY	b. AIR FORCE					
60	MOFZZ	MOOZZ		30554	95-8056-13-16	. . SLEEVING, INSULATION MAKE FROM ST-301-3/16 BLACK, WP 0153, BULK, ITEM 12, 1 IN. REQUIRED	1
61	MOFZZ	MOOZZ		30554	95-8056-13-13	. . WIRE, ELECTRICAL 16 MAKE FROM M16878/3BJE-9, WP 0153, BULK, ITEM 9, 7 IN. REQUIRED	1
62	PAFZZ	PAOZZ	5940-00-143-4780	98410	BB-837-10	. . TERMINAL, LUG	
63	AOFFF	AOOOO		30554	95-8056-14	. LEAD, ELECTRICAL(NOT SHOWN)....	1
64	PAFZZ	PAOZZ	5940-00-143-4780	98410	BB-837-10	. . TERMINAL, LUG	1
65	MOFZZ	MOOZZ		30554	95-8056-14-13	. . WIRE, ELECTRICAL 16 MAKE FROM M16878/3BJE-9, WP 0153, BULK, ITEM 9, 13 IN. REQUIRED.....	1
66	PAFZZ	PAOZZ	5940-01-356-6456	00779	640919-1	. . TERMINAL, QUICK DISC.	1
67	AOFFF	AOOOO		30554	95-8056-15	. LEAD, ELECTRICAL (NOT SHOWN)....	1
68	PAFZZ	PAOZZ	5940-00-230-0515	98410	BB-825-14	. . TERMINAL, LUG	1
69	MOFZZ	MOOZZ		30554	95-8056-15-13	. . WIRE, ELECTRICAL 16 MAKE FROM M16878/3BJE-9, WP 0153, BULK, ITEM 9, 29-1/4 IN. REQUIRED	1
70	PAFZZ	PAOZZ	5940-01-082-3321	15912	RB2573	. . TERMINAL, QUICK DISC.	1
71	AOFFF	AOOOO		30554	95-8056-16	. LEAD, ELECTRICAL(NOT SHOWN)....	1
72	PAFZZ	PAOZZ	5940-00-230-0515	98410	BB-825-14	. . TERMINAL, LUG	1
73	MOFZZ	MOOZZ		30554	95-8056-16-13	. . WIRE, ELECTRICAL 16 MAKE FROM M16878/3BJE-9, WP 0153, BULK, ITEM 9, 10 IN. REQUIRED.....	1
74	MOFZZ	MOOZZ		30554	95-8056-16-16	. . SLEEVING, INSULATION MAKE FROM ST-301-3/16 BLACK, WP 0153, BULK, ITEM 12, 1 IN. REQUIRED	1
75	PAFZZ	PAOZZ	5940-00-243-0409	06383	P14-6R	. .TERMINAL, LUG	1
76	AOFFF	AOOOO		30554	95-8056-17	. LEAD, ELECTRICAL(NOT SHOWN)....	1
77	PAFZZ	PAOZZ	5940-00-143-4780	98410	BB-837-10	. . TERMINAL, LUG	1
78	MOFZZ	MOOZZ		30554	95-8056-17-13	. .WIRE, ELECTRICAL 16 MAKE FROM M16878/3BJE-9, WP 0153, BULK, ITEM 9, 26-1/2 IN. REQUIRED	1
79	PAFZZ	PAOZZ		56501	RB14-12	. . TERMINAL, LUG	1
80	AOFFF	AOOOO		30554	95-8056-18	. LEAD, ELECTRICAL(NOT SHOWN)....	1
81	PAFZZ	PAOZZ	5940-00-243-0409	06383	P14-6R	. . TERMINAL, LUG	1
82	MOFZZ	MOOZZ		30554	95-8056-18-16	. . SLEEVING, INSULATION MAKE FROM ST-301-3/16 BLACK, WP 0153, BULK, ITEM 12, 1 IN. REQUIRED	1
83	MOFZZ	MOOZZ		30554	95-8056-18-13	. WIRE, ELECTRICAL 16 MAKE FROM M16878/3BJE-9, WP 0153, BULK, ITEM 9, 5 IN. REQUIRED	1
84	PAFZZ	PAOZZ		56501	RB14-12	. . TERMINAL, LUG	1
85	AOFFF	AOOOO		30554	95-8056-19	. LEAD, ELECTRICAL(NOT SHOWN)....	1
86	PAFZZ	PAOZZ	5940-01-068-1879	56501	RB-2577F	. . TERMINAL, QUICK DISC	1
87	MOFZZ	MOOZZ		30554	95-8056-19-13	. . WIRE, ELECTRICAL 16 MAKE FROM M16878/3BJE-9, WP 0153, BULK, ITEM 9, 9-1/8 IN. REQUIRED	1
88	MOFZZ	MOOZZ		30554	95-8056-19-16	. . SLEEVING, INSULATION MAKE FROM ST-301-3/16 BLACK, WP 0153, BULK, ITEM 12, 1 IN. REQUIRED	1
89	PAFZZ	PAOZZ	5940-00-243-0409	06383	P14-6R	. . TERMINAL, LUG	1
90	AOFFF	AOOOO		30554	95-8056-20	. LEAD, ELECTRICAL(NOT SHOWN)....	1
91	PAFZZ	PAOZZ	5940-01-465-3185	06383	PV8-10R-Q	. . TERMINAL, LUG	1

(1)	(2)		(3)	(4)	(5)	(6)	(7)
ITEM NO	SMR CODE		NSN	CAGEC	PART NUMBER	DESCRIPTION AND USABLE ON CODE (UOC)	QTY
	a. ARMY	b. AIR FORCE					
92	MOFZZ	MOOZZ		30554	95-8056-20-6	. . WIRE, ELECTRICAL 8 MAKE FROM M16878/3BNL-9, WP 0153, BULK, ITEM 10, 8-1/2 IN. REQUIRED	1
93	PAFZZ	PAOZZ	5940-01-465-4413	06383	PV8-38R-Q	. . TERMINAL, LUG	1
94	AOFFF	AOOOO		30554	95-8056-21	. LEAD, ELECTRICAL(NOT SHOWN).....	1
95	PAFZZ	PAOZZ	5940-01-467-8197	06383	PV4-14R-E	. . TERMINAL, LUG	2
96	MOFZZ	MOOZZ		30554	95-8056-21-4	. . WIRE, ELECTRICAL 4 MAKE FROM M16878/3BRL-9, WP 0153, BULK, ITEM 14, 13 IN. REQUIRED	1
97	AOFFF	AOOOO		30554	95-8056-22	. LEAD, ELECTRICAL(NOT SHOWN)...	1
98	PAFZZ	PAOZZ	5940-01-467-8197	06383	PV4-14R-E	. . TERMINAL, LUG	1
99	MOFZZ	MOOZZ		30554	95-8056-22-4	. . WIRE, ELECTRICAL 4 MAKE FROM M16878/3BRL-9, WP 0153, BULK, ITEM 14, 15-1/4 IN. REQUIRED	1
100	PAFZZ	PAOZZ	5940-01-467-8190	06383	PV4-12R-E	. . TERMINAL, LUG	1
101	AOFFF	AOOOO		30554	95-8056-23	. LEAD, ELECTRICAL(NOT SHOWN).....	1
102	PAFZZ	PAOZZ	5940-01-467-8190	06383	PV4-12R-E	. . TERMINAL, LUG	1
103	MOFZZ	MOOZZ		30554	95-8056-23-4	. . WIRE, ELECTRICAL 4 MAKE FROM M16878/3BRL-9, WP 0153, BULK, ITEM 14, 11-1/4 IN. REQUIRED	1
104	PAFZZ	PAOZZ	5940-01-467-8197	06383	PV4-38R-E	. . TERMINAL, LUG	1
105	AOFFF	AOOOO		30554	95-8056-24	. LEAD, ELECTRICAL(NOT SHOWN).....	1
106	PAFZZ	PAOZZ	5940-01-467-8197	06383	PV4-14R-E	. . TERMINAL, LUG	1
107	MOFZZ	MOOZZ		30554	95-8056-24-4	. . WIRE, ELECTRICAL 4 MAKE FROM M16878/3BRL-9, WP 0153, BULK, ITEM 14, 5-5/8 IN. REQUIRED	1
108	PAFZZ	PAOZZ	5940-01-467-8197	06383	PV4-38R-E	. . TERMINAL, LUG	1

END OF FIGURE

OPERATOR AND FIELD MAINTENANCE
2 kW MEP-501A/531A MILITARY TACTICAL GENERATOR SETS
GROUP 0413 CAPACITOR ASSEMBLY (MEP-501A)

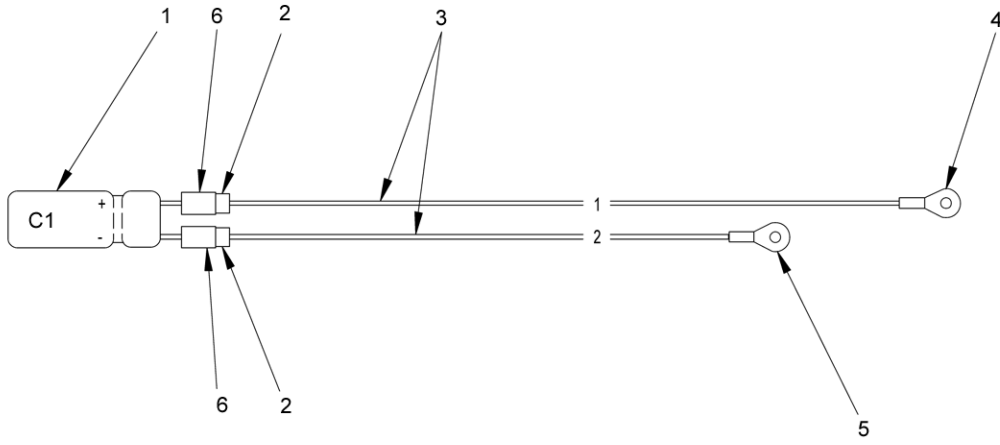

Figure 31. Capacitor Assembly (MEP-501A).

(1)	(2)		(3)	(4)	(5)	(6)	(7)
ITEM NO	SMR CODE		NSN	CAGEC	PART NUMBER	DESCRIPTION AND USABLE ON CODE (UOC)	QTY
	a. ARMY	b. AIR FORCE					

GROUP 0413 CAPACITOR ASSEMBLY (MEP-501A)

FIG. 31 CAPACITOR ASSEMBLY (MEP-501A)

1	PAFZZ	PAOZZ	5910-01-420-0466	62643	LXF63VB102M16X40LL	. CAPACITOR, FIXED, E	1
2	PAFZZ	PAOZZ	5940-00-636-5536	00779	34068	. SPLICE, CONDUCTOR	2
3	MOFZZ	MOOZZ		30554	95-8017-5	. WIRE, ELECTRICAL 16 MAKE FROM M16878/3BJE-9, WP 0153, BULK, ITEM 9, 23-1/4 IN. REQUIRED	1
4	PAFZZ	PAOZZ	5940-00-230-0515	98410	BB-825-14	. TERMINAL, LUG	1
5	PAFZZ	PAOZZ	5940-01-458-9497	56501	RB14-12	. TERMINAL, LUG	1
6	MOFZZ	MOOZZ		30554	95-8017-6	. SLEEVING, INSULATION MAKE FROM ST-301-3/64 BLACK, WP 0153, BULK, ITEM 20, 2 IN. REQUIRED	1

END OF FIGURE

OPERATOR AND FIELD MAINTENANCE

2 kW MEP-501A/531A MILITARY TACTICAL GENERATOR SETS

GROUP 0414 TRANSIENT SUPPRESSOR ASSEMBLY (MEP-501A)

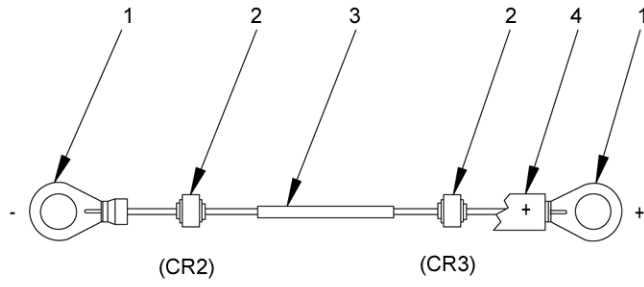

Figure 32. Transient Suppressor Assembly (MEP-501A).

(1)	(2)		(3)	(4)	(5)	(6)	(7)
ITEM NO	SMR CODE		NSN	CAGEC	PART NUMBER	DESCRIPTION AND USABLE ON CODE (UOC)	QTY
	a. ARMY	b. AIR FORCE					

**GROUP 0414 TRANSIENT
SUPPRESSOR ASSEMBLY
(MEP-501A)**

**FIG. 32 TRANSIENT
SUPPRESSOR ASSEMBLY
(MEP-501A)**

1	PAFZZ	PAOZZ	5940-01-458-9497	56501	RB14-12	. TERMINAL, LUG	2
2	PAFZZ	PAOZZ	5961-01-467-6714	04713	MR2535L	. DIODE, TRANSIENT SUPP.	2
3	PAFZZ	PAOZZ	5940-00-636-5536	00779	34068	. SPLICE, CONDUCTOR	1
4	XBFZZ	XBOZZ		30554	95-8139	. MARKER, IDENTIFICATION	1

END OF FIGURE

OPERATOR AND FIELD MAINTENANCE
2 kW MEP-501A/531A MILITARY TACTICAL GENERATOR SETS
GROUP 05 ENGINE WIRING HARNESS (MEP-531A/501A)

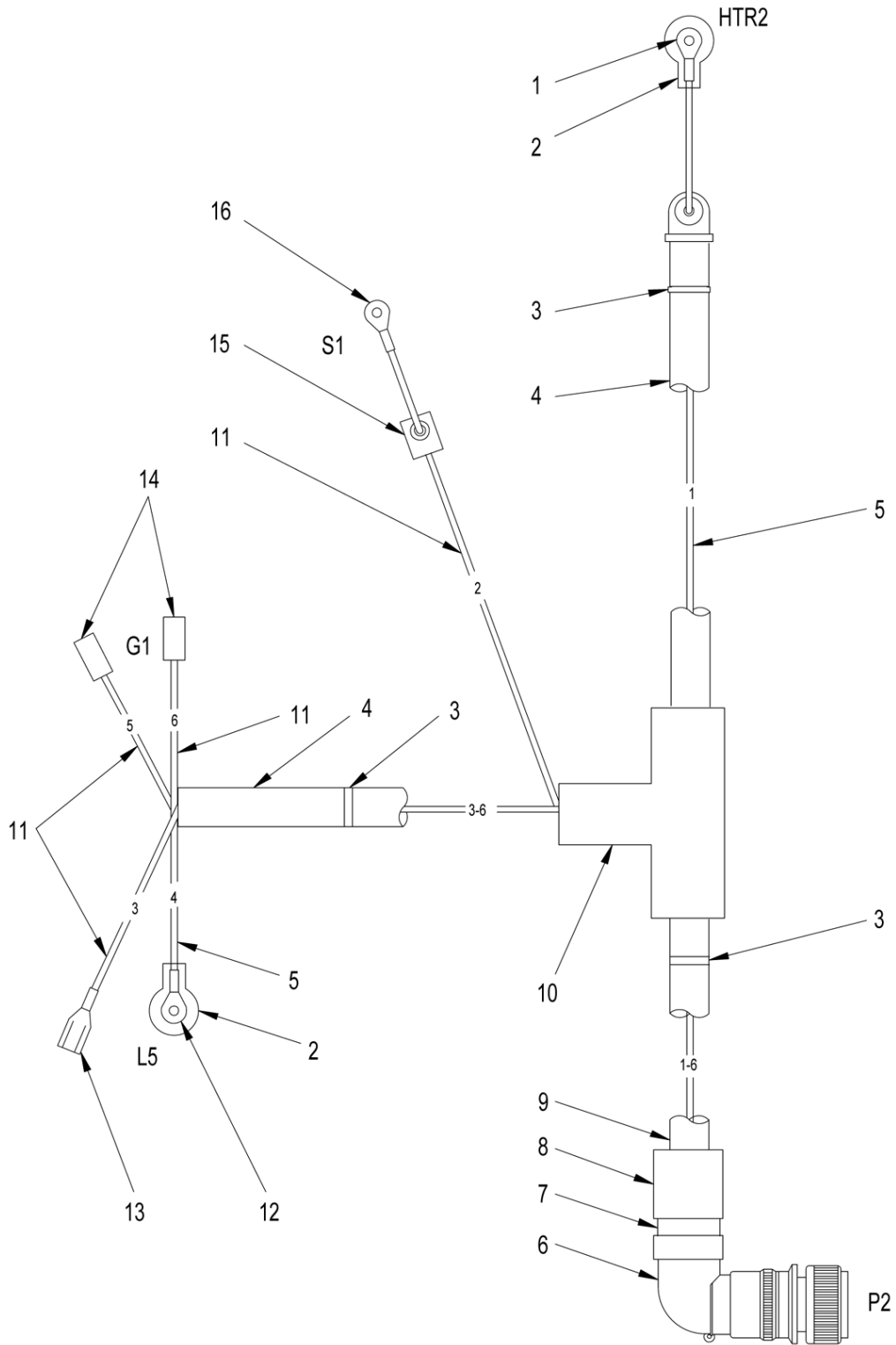

Figure 33. Engine Wiring Harness (MEP-531A/501A).

(1)	(2)		(3)	(4)	(5)	(6)	(7)
ITEM NO	SMR CODE		NSN	CAGEC	PART NUMBER	DESCRIPTION AND USABLE ON CODE (UOC)	QTY
	a. ARMY	b. AIR FORCE					
GROUP 05 ENGINE WIRING HARNESS (MEP-531A/501A)							
FIG. 33 ENGINE WIRING HARNESS (MEP-531A/501A)							
1	XBFZZ	XBOZZ	5940-01-336-7253	06383	P8-14R	. TERMINAL, LUG	1
2	XBFZZ	XBOZZ	5975-01-467-9255	3AE86	76-0706	. CABLE NIPPLE, ELECT	2
3	XBFZZ	XBOZZ	5975-00-111-3208	43999	LE127-0011-0005	. STRAP, TIEDOWN, ELEC.	15
4	MOFZZ	MOOZZ		30554	95-8029-7	. TUBING, CONVOLUTED MAKE FROM 038FEJSX0000XBS, WP 0153, BULK, ITEM 17, APPROX. 41 IN. REQUIRED	1
5	MOFZZ	MOOZZ		30554	95-8029-14	. WIRE, ELECTRICAL 8 MAKE FROM M16878/3BNL-9, WP 0153, BULK, ITEM 10, 72-1/4 IN. REQUIRED	1
6	XBFZZ	XBOZZ	5935-01-316-8302	71468	CA3108R20-8S-F80	. CONNECTOR, PLUG, ELEC.	1
7	XBFZZ	XBOZZ		71468	M85049/41-12A WITH BUSHING	. CLAMP, CABLE ELEC. (MEP-531A)	1
7	XBFZZ	XBOZZ		71468	M85049/41-12A WITH BUSHING	. CLAMP, CABLE ELEC. (MEP-501A)	1
8	MOFZZ	MOOZZ		30554	95-8029-16	. SLEEVING, INSULATION MAKE FROM ST-301-1-1/2 BLACK, WP 0153, BULK, ITEM 21, 2 IN. REQUIRED	1
9	MOFZZ	MOOZZ		30554	95-8029-3	. TUBING, CONVOLUTED MAKE FROM 012FEJSX0000XBS, WP 0153, BULK, ITEM 5, APPROX. 10-1/2 IN. REQUIRED	1
10	XBFZZ	XBOZZ		77060	8917000	. TEE, ELECTRICAL CON.	1
11	MOFZZ	MOOZZ		30554	95-8029-13	. WIRE, ELECTRICAL 16 MAKE FROM M16878/3BJE-9, WP 0153, BULK, ITEM 9, 120 IN. REQUIRED	1
12	XBFZZ	XBOZZ	5940-01-465-3177	06383	P8-56R-Q	. TERMINAL, LUG	1
13	XBFZZ	XBOZZ	5940-01-082-3321	15912	RB2573	. TERMINAL, QUICK DISC	1
14	XBFZZ	XBOZZ	5940-01-316-4525	14726	MP4847F	. TERMINAL, QUICK DISC	2
15	XBFZZ	XBOZZ		35537	A00864	. BOOT, RUBBER	1
16	XBFZZ	XBOZZ		06383	P14-10R	. TERMINAL, LUG	1

END OF FIGURE

OPERATOR AND FIELD MAINTENANCE

2 kW MEP-501A/531A MILITARY TACTICAL GENERATOR SETS

GROUP 06 LOP ENGINE SHUTDOWN CABLE ASSEMBLY (MEP-531A/501A)

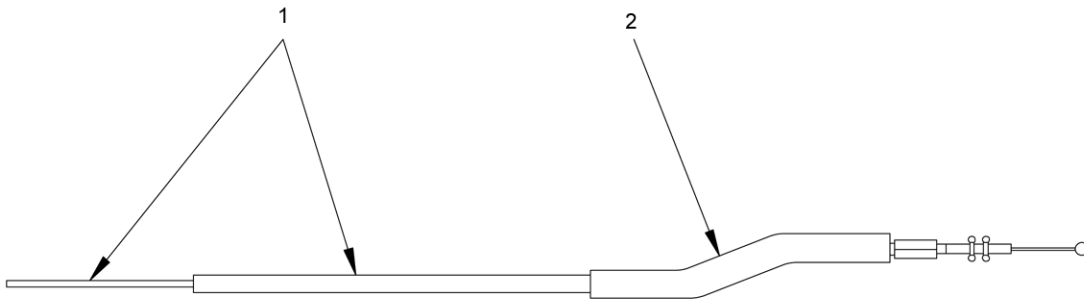

Figure 34. LOP Engine Shutdown Cable Assembly (MEP-531A/501A).

(1)	(2)		(3)	(4)	(5)	(6)	(7)
ITEM NO	SMR CODE		NSN	CAGEC	PART NUMBER	DESCRIPTION AND USABLE ON CODE (UOC)	QTY
	a. ARMY	b. AIR FORCE					

GROUP 06 LOP ENGINE
SHUTDOWN CABLE
ASSEMBLY
(MEP-531A/501A)

FIG. 34 LOP ENGINE SHUTDOWN
CABLE ASSEMBLY
(MEP-531A/501A)

1	PAFZZ	PAOZZ	6620-01-467-7571	0AK42	114970-66400	. CONTROL ASSEMBLY	1
2	PAFZZ	PAOZZ	5975-01-467-6588	30554	95-8081	. TUBE, CABLE OFFSET	1

END OF FIGURE

OPERATOR AND FIELD MAINTENANCE
2 kW MEP-501A/531A MILITARY TACTICAL GENERATOR SETS
GROUP 07 PREHEATER LEAD ASSEMBLY (MEP-531A/501A)

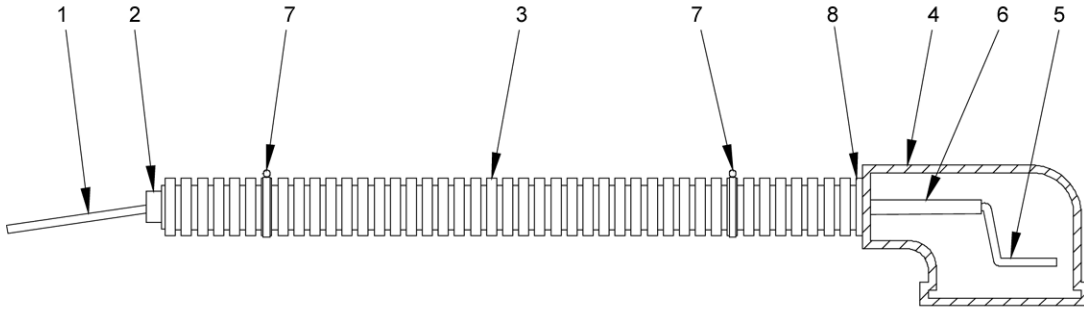

Figure 35. Preheater Lead Assembly (MEP-531A/501A).

(1)	(2)		(3)	(4)	(5)	(6)	(7)
ITEM NO	SMR CODE		NSN	CAGEC	PART NUMBER	DESCRIPTION AND USABLE ON CODE (UOC)	QTY
	a. ARMY	b. AIR FORCE					
GROUP 07 PREHEATER LEAD ASSEMBLY (MEP-531A/501A) FIG. 35 PREHEATER LEAD ASSEMBLY (MEP-531A/501A)							
1	PAFZZ	PAOZZ	5940-01-465-3177	06383	P8-56R-Q	. TERMINAL, LUG	1
2	MOFZZ	MOOZZ		30554	95-8141-8	. SLEEVING, INSULATION MAKE FROM ST-301-3/8 BLACK, WP 0153, BULK, ITEM 11, 1 IN. REQUIRED	1
3	MOFZZ	MOOZZ		30554	95-8141-2	. TUBING, CONVOLUTED MAKE FROM 038FEJSX0000XBS, WP 0153, BULK, ITEM 17, 6 IN. REQUIRED	1
4	PAFZZ	PAOZZ	5975-01-467-9255	3AE86	76-0706	. CABLE NIPPLE, ELEC.	1
5	PAFZZ	PAOZZ	5940-01-336-7253	06383	P8-14R	. TERMINAL, LUG	1
6	MOFZZ	MOOZZ		30554	95-8141-5	. WIRE, ELECTRICAL 8 MAKE FROM M16878/3BNL-9, WP 0153, BULK, ITEM 10, 8 IN. REQUIRED	1
7	XBFZZ	XBOZZ	5975-00-111-3208	43999	LE127-0011-0005	. STRAP, TIEDOWN, ELEC.	2
8	MOFZZ	MOOZZ		30554	95-8141-7	. SLEEVING, INSULATION MAKE FROM ST-301-3/4 BLACK, WP 0153, BULK, ITEM 22, 2 IN. REQUIRED	1

END OF FIGURE

OPERATOR AND FIELD MAINTENANCE
2 kW MEP-501A/531A MILITARY TACTICAL GENERATOR SETS
GROUP 08 ALTERNATOR WIRING HARNESS (MEP-501A)

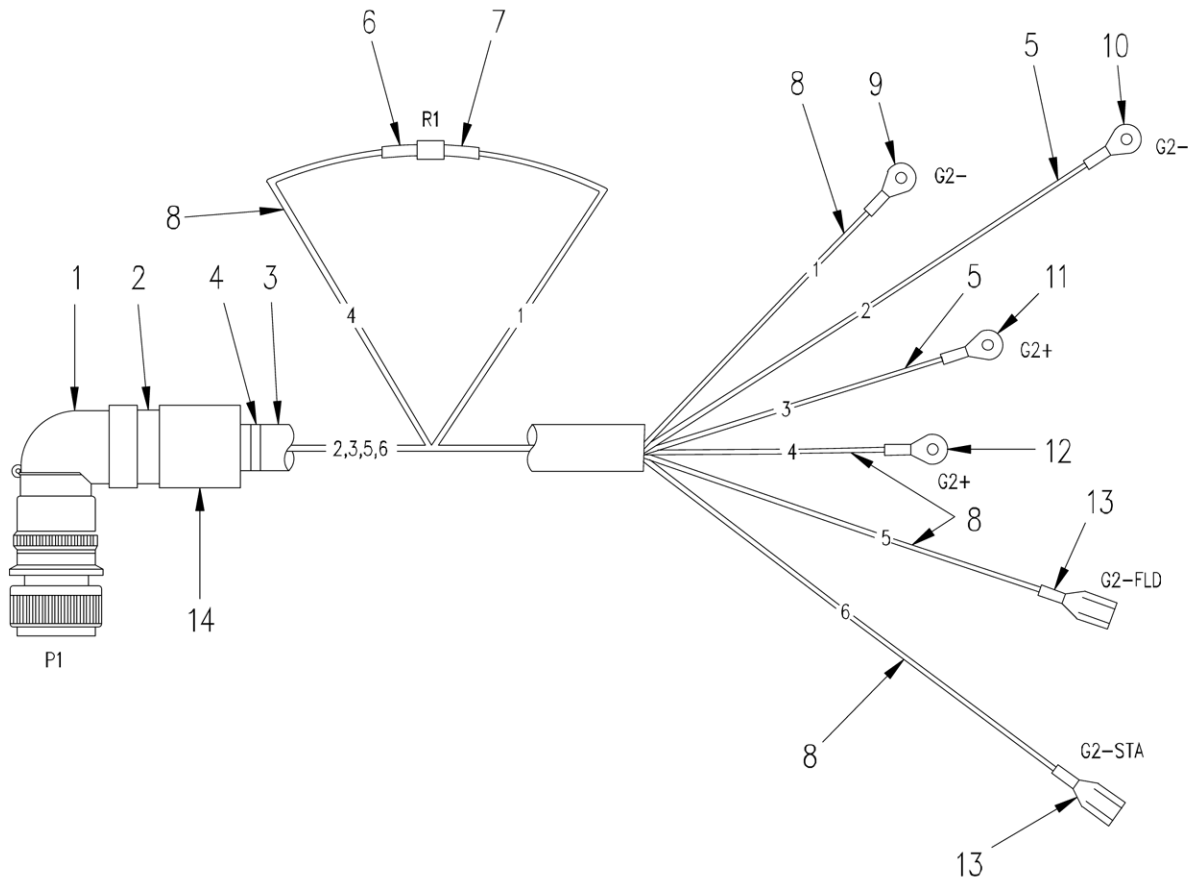

Figure 36. Alternator Wiring Harness (MEP-501A).

(1)	(2)		(3)	(4)	(5)	(6)	(7)
ITEM NO	SMR CODE		NSN	CAGEC	PART NUMBER	DESCRIPTION AND USABLE ON CODE (UOC)	QTY
	a. ARMY	b. AIR FORCE					
GROUP 08 ALTERNATOR WIRING HARNESS (MEP-501A)							
FIG. 36 ALTERNATOR WIRING HARNESS (MEP-501A)							
1	XBFZZ	XBOZZ		71468	CA3108R24-12S-F80	. CONNECTOR, PLUG, ELEC.	1
2	XBFZZ	XBOZZ		71468	M85049/41-16A WITH BUSHING	. CLAMP, CABLE, ELEC.	1
3	MOFZZ	MOOZZ		30554	95-8028-3	. TUBING, CONVOLUTED MAKE FROM 034FEJSX0000XBS, WP 0153, BULK, ITEM 18, 8 IN. REQUIRED	1
4	PAFZZ	PAOZZ	5975-00-111-3208	43999	LE127-0011-0005	. STRAP, TIEDOWN, ELEC.	3
5	MOFZZ	MOOZZ		30554	95-8028-10	. WIRE, ELECTRICAL 4 MAKE FROM M16878/3BRL-9, WP 0153, BULK, ITEM 14, 25-3/4 IN. REQUIRED	1
6	XBFZZ	XBOZZ	5940-00-230-0515	17826	RH05020R00F	. RESISTOR, FIXED, WIRE	1
7	MOFZZ	MOOZZ		30554	95-8028-13	. SLEEVING, INSULATION MAKE FROM ST-301-3/16 BLACK, WP 0153, BULK, ITEM 12, 2 IN. REQUIRED	1
8	MOFZZ	MOOZZ		30554	95-8028-11	. WIRE, ELECTRICAL 14 MAKE FROM M16878/3BKE-9, WP 0153, BULK, ITEM 13, 55-1/2 IN. REQUIRED	1
9	XBFZZ	XBOZZ		98410	BB-825-14	. TERMINAL, LUG	1
10	XBFZZ	XBOZZ	5940-01-467-8197	06383	PV4-14R-E	. TERMINAL, LUG	1
11	XBFZZ	XBOZZ		06383	PV4-56R	. TERMINAL, LUG	1
12	XBFZZ	XBOZZ	5940-00-283-5281	96906	MS25036-109	. TERMINAL, LUG, SMALL	1
13	XBFZZ	XBOZZ	5940-00-620-9780	00779	42282-2	. TERMINAL, QUICK DISC.	2
14	MOFZZ	MOOZZ		30554	95-8028-14	. SLEEVING, INSULATION MAKE FROM ST-301-1-1/2 BLACK, WP 0153, BULK, ITEM 21, 2 IN. REQUIRED	1

END OF FIGURE

OPERATOR AND FIELD MAINTENANCE

2 KW MEP-501A/531A MILITARY TACTICAL GENERATOR SETS

BULK ITEMS

(1)	(2)		(3)	(4)	(5)	(6)	(7)
ITEM NO	SMR CODE		NSN	CAGEC	PART NUMBER	DESCRIPTION AND USABLE ON CODE (UOC)	QTY
	ARMY	AIR FORCE					

GROUP 09 BULK ITEMS

1	XBFZZ	XBOZZ		30554	ASTM D 1056	RUBBER, CLOSED-CELL	V
2	PAFZZ	PAOZZ		1DS07	AEM02022	TUBING, FLEXIBLE	V
3	PAFZZ	PAOZZ		1DS07	AEM02012	TUBING, FLEXIBLE	V
4	XBFZZ	XBOZZ		30554	SAE 30305	WIRE, RETAINING	V
5	XBFZZ	XBOZZ		0FB20	012FEJSX0000XBS	TUBING, CONVOLUTED	V
6	XBFZZ	XBOZZ		28105	ST-301-1/2 BLACK	SLEEVING, INSULATION	V
7	XBFZZ	XBOZZ		94223	RW-25SBR	PROTECTOR, EDGE	V
8	XBFZZ	XBOZZ		28105	ST-301-1/8 BLACK	SLEEVING, INSULATION	V
9	XBFZZ	XBOZZ		3N861	M16878/3BJE-9	WIRE, ELECTRICAL 16	V
10	XBFZZ	XBOZZ		3N861	M16878/3BNL-9	WIRE, ELECTRICAL 8	V
11	XBFZZ	XBOZZ		28105	ST-301-3/8 BLACK	SLEEVING, INSULATION	V
12	XBFZZ	XBOZZ		28105	ST-301-3/16 BLACK	SLEEVING, INSULATION	V
13	XBFZZ	XBOZZ		3N861	M16878/3BKE-9	WIRE, ELECTRICAL 14	V
14	XBFZZ	XBOZZ		3N861	M16878/3BRL-9	WIRE, ELECTRICAL 4	V
15	XBFZZ	XBOZZ		28105	ST-301-1/4 WHITE	SLEEVING, INSULATION	V
16	XBFZZ	XBOZZ		0FB20	716FEJSX0000XBS	TUBING, CONVOLUTED	V
17	XBFZZ	XBOZZ		0FB20	038FEJSX0000XBS	TUBING, CONVOLUTED	V
18	XBFZZ	XBOZZ		0FB20	034FEJSX0000XBS	TUBING, CONVOLUTED	V
19	XBFZZ	XBOZZ		35537	M44A0111-14-0	WIRE, 14AWG, TY	V
20	XBFZZ	XBOZZ		28105	ST-301-3/64 BLACK	SLEEVING, INSULATION	V
21	XBFZZ	XBOZZ		28105	ST-301-1-1/2 BLACK	SLEEVING, INSULATION	V
22	XBFZZ	XBOZZ		28105	ST-301-3/4 BLACK	SLEEVING, INSULATION	V

END OF FIGURE

OPERATOR AND FIELD MAINTENANCE
2 KW MEP-501A/531A MILITARY TACTICAL GENERATOR SETS
SPECIAL TOOLS LIST

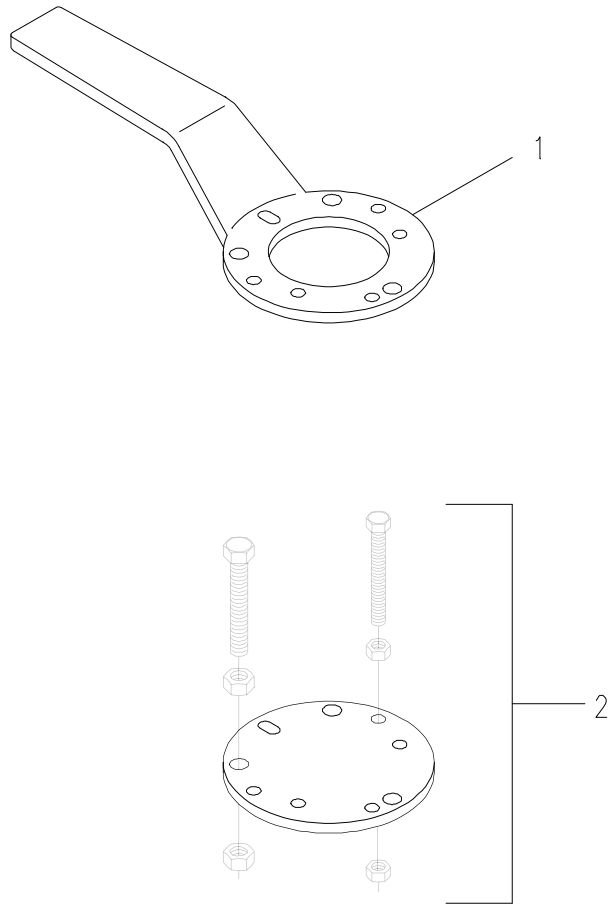

Figure 1. Special Tools for Field Maintenance (Diesel Engine).

(1)	(2)		(3)	(4)	(5)	(6)	(7)
ITEM NO	SMR CODE		NSN	CAGEC	PART NUMBER	DESCRIPTION AND USABLE ON CODE (UOC)	QTY
	a. ARMY	b. AIR FORCE					

GROUP 10 SPECIAL TOOLS LIST

1	PAFZZ	PAFZZ		0AK42	114250-92101	FLYWHEEL TIGHTENING HANDLE	1
2	PAFZZ	PAFZZ		0AK42	114250-92130	FLYWHEEL EXTRACTOR	1

END OF FIGURE

END OF WORK PACKAGE

OPERATOR AND FIELD MAINTENANCE
2 kW MEP-501A/531A MILITARY TACTICAL GENERATOR SETS
NSN INDEX

STOCK NUMBER	FIG.	ITEM	STOCK NUMBER	FIG.	ITEM
5940-00-021-3321	21	57	5940-00-230-0515	27	4
5306-00-050-1238	6	7		29	20
5305-00-068-0509	6	19		29	25
4730-00-071-7890	3	8		29	29
5975-00-111-3208	1	21		29	47
	6	31		29	51
	21	73		29	53
	22	74		29	61
	33	3		29	65
	35	7		30	73
	36	4		30	68
5940-00-143-4774	30	2		30	72
	30	6		31	4
	30	10	5940-00-243-0409	31	4
5940-00-143-4780	26	6		36	9
	28	7		21	51
	29	2		22	46
	29	8		24	4
	29	10		25	4
	29	18		26	7
	29	22		27	5
	29	37		28	1
	29	42		29	13
	29	56		29	31
	29	59		29	34
	30	4		29	39
	30	8		29	44
	30	15		30	12
	30	57		30	19
	30	62		30	24
	30	64		30	29
	30	77		30	34
5940-00-143-5284	29	75		30	39
5325-00-174-9038	21	32		30	44
	22	27		30	49
5310-00-189-8467	22	59		30	54
5305-00-225-3843	21	42	5925-00-267-1447	22	66
	22	36	5325-00-276-6343	8	16
5310-01-328-7657	6	14	5920-00-280-8342	21	18
5310-00-933-8120	6	28		22	10
5310-00-809-4058	6	34	5325-00-281-1557	6	23

STOCK NUMBER	FIG.	ITEM	STOCK NUMBER	FIG.	ITEM
5940-00-283-5281	36	12	5977-01-105-6201	19	13
4820-00-495-9680	4	6	3010-01-149-7959	7	17
5305-00-543-2866	7	14	5310-01-155-3857	1	26
5940-00-620-9780	36	13		3	22
6150-00-632-7234	21	54	5305-01-163-5075	16	9
5940-00-636-5536	25	2	5999-01-210-6449	19	12
	28	5	5940-01-233-1810	21	56
	31	2	5305-01-255-6548	10	2
	32	3		12	7
5905-00-646-5958	24	1	5940-01-259-2190	29	49
5905-00-665-4992	24	9		29	63
5320-00-882-8388	6	21		29	71
	7	28	5305-01-300-6263	3	20
	23	2	5305-01-300-6264	8	12
4730-00-930-7776	1	30		12	3
5320-00-932-1972	21	17		16	11
	22	9	5306-01-300-6265	6	12
	23	10	5305-01-303-5631	1	17
5940-00-958-1214	22	53	2940-01-310-4495	8	5
5305-00-983-7429	19	9	2910-01-310-4522	17	3
5305-00-990-8632	7	16	5940-01-316-4525	33	14
5975-00-992-8396	21	68	5935-01-316-8302	33	6
5961-00-997-8021	28	3	5935-01-317-6752	27	1
5920-01-005-9621	21	19	2815-01-319-3174	11	16
	22	11	5310-01-319-8589	6	8
5940-01-068-1879	29	65	4730-01-322-4956	10	16
	30	86	3020-01-322-5785	16	4
5305-01-069-8235	16	8	5310-01-322-8607	12	1
5940-01-082-3321	29	16	5360-01-322-8631	15	20
	29	27	5325-01-322-8679	14	3
	29	73	5365-01-322-8692	11	13
	30	22	3110-01-322-9532	13	3
	30	27	2815-01-323-0286	14	2
	30	32	2815-01-323-0290	11	18
	30	37	2815-01-323-0291	11	19
	30	42	4320-01-323-0298	15	4
	30	47	2990-01-323-0307	16	10
	30	52	2815-01-323-0351	14	4
	30	70			
	33	13			
5975-01-090-8876	21	13			
5935-01-097-9974	21	70			
	22	68			

STOCK NUMBER	FIG.	ITEM	STOCK NUMBER	FIG.	ITEM
2815-01-323-0352	13	13	5330-01-353-6007	10	9
2815-01-323-0353	13	15	2815-01-353-7523	15	7
2815-01-323-1352	11	10	2990-01-353-7531	15	9
5306-01-323-5440	11	1	3110-01-354-3572	10	8
5307-01-323-5503	11	15	5940-01-356-6456	29	4
5307-01-323-5504	11	17		29	6
5307-01-323-5505	12	8		30	17
5342-01-323-7866	16	6		30	66
5342-01-324-0772	21	59	5342-01-359-6858	10	5
	22	55	5305-01-365-6314	3	4
5360-01-324-3995	11	24	5310-01-366-3539	6	6
3120-01-324-5762	10	7		7	6
2815-01-324-6801	11	11	5305-01-373-4831	1	34
2815-01-324-6802	11	4	5940-01-374-3138	1	11
5330-01-324-8253	10	1	5305-01-380-3395	1	20
5330-01-324-8254	10	18		6	13
5331-01-324-8279	15	3	5305-01-388-6229	15	8
5330-01-324-8287	12	5	5306-01-388-6230	11	6
3110-01-324-8815	10	30	5306-01-388-7402	15	1
3110-01-324-8817	10	29		16	1
5331-01-324-8831	11	23		18	4
5340-01-324-8850	11	25	5310-01-388-8806	16	7
2815-01-324-9200	16	5	5310-01-388-8825	15	11
5330-01-326-2669	10	17	5310-01-388-8826	10	22
5330-01-326-4773	12	11		11	12
5330-01-326-4780	12	4		12	10
5331-01-326-8017	15	6	5315-01-388-8937	13	11
5330-01-326-8021	11	14	5340-01-389-1309	16	2
5330-01-326-8022	11	5	3010-01-389-9003	15	16
5331-01-328-4148	10	28	2815-01-389-9590	13	12
5330-01-328-4171	10	20	3040-01-389-9592	15	10
4240-01-328-4878	4	2	5305-01-391-3563	21	36
5310-01-328-7657	1	15		22	30
	6	14	2815-01-393-9880	11	9
5330-01-330-9564	16	3	5310-01-398-0737	13	7
5940-01-336-7253	33	1	5310-01-411-0862	21	34
	35	5		22	28
2815-01-348-5888	13	14	5340-01-415-3789	10	21
			5330-01-415-3802	15	15
			5365-01-415-6744	10	23

STOCK NUMBER	FIG.	ITEM	STOCK NUMBER	FIG.	ITEM
5120-01-415-8266	37	1	2910-01-425-1722	5	4
5360-01-415-8733	15	19	4710-01-425-8674	17	2
5945-01-416-0380	25	1	5977-01-426-1442	20	6
5120-01-416-0424	37	2	2990-01-428-4216	11	8
3110-01-417-1057	10	26	5360-01-431-3108	15	14
3110-01-417-1465	15	12	5310-01-431-4064	11	22
5315-01-419-3159	20	1	5310-01-431-4066	15	13
3010-01-419-3164	20	23	5310-01-431-4067	10	13
6115-01-419-3165	20	2	5310-01-431-4068	10	10
6115-01-419-3166	20	22	5310-01-431-4069	13	2
3110-01-419-3167	20	19	5310-01-431-4070	13	8
6115-01-419-3170	19	2	5307-01-431-7454	11	20
5306-01-419-3173	19	8	5306-01-431-7457	15	21
5310-01-419-3175	20	25	5306-01-431-7460	18	1
6110-01-419-3179	22	23	5306-01-431-7461	10	3
6115-01-419-3193	7	15	5306-01-431-7462	13	1
5305-01-419-3551	23	12	5331-01-431-7566	5	3
5306-01-419-4096	6	2	5315-01-431-8229	15	5
	7	2	5315-01-431-8230	11	21
5365-01-419-5477	12	9	5315-01-432-1210	13	10
5340-01-419-5478	5	5	5315-01-432-2457	10	6
5331-01-419-5479	10	12	5340-01-433-5457	15	2
2920-01-419-5481	18	5	5340-01-433-5460	11	2
2990-01-419-5482	12	2	5305-01-435-4122	21	41
5360-01-419-5483	15	17		22	35
2910-01-419-5484	17	1	5305-01-435-6260	1	29
5930-01-419-6559	21	67	5310-01-436-4437	1	18
	22	64		6	3
2815-01-419-8704	8	19		7	3
3120-01-419-9010	20	18	5340-01-449-3915	11	3
5910-01-420-0466	31	1	5961-01-450-6429	20	26
5961-01-420-0966	20	27	2920-01-452-8409	18	2
2910-01-420-9067	5	2	3110-01-458-4163	20	13
2940-01-421-1106	8	4	5930-01-458-5607	1	31
5306-01-423-2038	1	1	6645-01-458-7278	21	24
	3	25		22	18
4520-01-424-6353	12	12			
5961-01-425-0277	20	28			

STOCK NUMBER	FIG.	ITEM	STOCK NUMBER	FIG.	ITEM
5310-01-458-7561	7	11	5940-01-467-8190	19	1
	21	27		27	11
	22	22		30	100
		30		102	
6125-01-458-7856	6	9	5940-01-467-8197	27	9
5940-01-458-9497	30	79		30	95
	30	84		30	98
	31	5		30	106
	32	1		36	10
5310-01-458-9991	10	11	30	104	
5975-01-461-2989	20	21	30	108	
4720-01-464-0400	BULK	2	5975-01-467-9255	33	2
4720-01-464-0411	BULK	3		35	4
5925-01-464-2030	21	74	4330-01-468-5065	6	22
5940-01-465-3177	33	12		7	29
	35	1	5330-01-472-5601	8	3
5940-01-465-3185	26	5	6115-01-472-5875	19	10
	29	67	5340-01-472-8707	21	25
	30	91	5340-01-473-4697	22	19
5905-01-465-3266	21	53	6115-01-474-6268	19	3
	22	50	6110-01-474-8025	21	50
5940-01-465-4413	26	8		22	45
	29	69	5365-01-479-1380	4	4
	29	77	4820-01-480-0846	4	5
	30	93	2910-01-488-7002	3	18
6110-01-465-5952	21	29	2910-01-497-1023	4	3
5310-01-467-2665	8	1	5342-21-914-6301	1	16
5950-01-467-3238	8	11		6	16
5330-01-467-6273	8	9	6625-99-562-7769	21	1
5975-01-467-6588	34	2	6625-99-623-6974	21	4
5961-01-467-6714	32	2	6625-99-629-8742	22	3
4330-01-467-6774	3	23	5305-01-300-6264	16	11
5310-01-467-6832	1	35	6625-99-257-9279	22	3
	6	18	5310-01-466-6312	22	33
	21	38	5305-01-435-4122	22	35
5925-01-467-7122	22	32	5302-00-225-3843	22	36
2930-01-467-7548	22	75	5330-01-467-3998	22	37
2990-01-467-7570	4	1	5310-01-413-4592	22	61
6620-01-467-7571	34	1	5310-00-208-9255	22	62
6620-01-467-7577	21	2	5975-01-177-5687	22	73
2835-01-467-7598	22	1			
3110-01-467-7863	8	17			

END OF WORK PACKAGE

OPERATOR AND FIELD MAINTENANCE
2 kW MEP-501A/531A MILITARY TACTICAL GENERATOR SETS
P/N INDEX

PART NUMBER	FIG.	ITEM	PART NUMBER	FIG.	ITEM
012FEJSX0000XBS	BULK	5	11-1503	20	33
0200A1805AB0001	21	2	11-2045	20	3
034FEJSX0000XBS	BULK	18	11-2701	20	14
038FEJSX0000XBS	BULK	17	11-2703	20	15
083-41S2-211485	21	1	11-2707	20	32
083-75A2-211841	21	4	11-2708	20	41
083-80A2-211844	22	3	11-2709	20	11
083-80V2-211843	22	1	11-2710	20	1
102103-55520	5	3	11-2712	20	6
10-2718	20	29	11-2713	20	31
103338-32570	15	3	11-2714-1	20	47
103854-01221	13	7	11-2715-1	20	39
10501762	1	26	11-2717-3	20	30
	3	22	11-2723	20	7
10512	10	2	11-2745	20	38
	12	7	11-3010	20	2
105425-01690	10	16	11-3300	20	20
10-94-24-M2-PC	7	15	11-3301	20	22
11-1025	20	24	11-3302	20	17
11-1030	20	25	11-3303-1	20	19
11-1070	20	34	11-3304	20	18
11-1072-1	20	13	11-3305	20	21
11-1079	20	45	11-3306	20	16
11-1080	20	44	11-3308	20	9
11-1081	20	5	11-3309	20	10
11-1083	20	40	11-3310	20	12
11-1093	20	8	114250-01200	10	27
11-1094	20	36	114250-01210	10	14
11-1097	20	4	114250-01220	10	10
11-1098	20	46	114250-01250	10	13
11-1099	20	35	114250-01380	10	28
11-1109	20	42	114250-01412	10	9
11-1113	20	37			

PART NUMBER	FIG.	ITEM	PART NUMBER	FIG.	ITEM
114250-01800	10	23	114250-45300	16	5
114250-01830	10	21	114250-45310	16	6
114250-01841	10	20	114250-45330	16	3
114250-02030	10	26	114250-55100	4	2
114250-02100	10	7	114250-55510	5	2
114250-02113	10	8	114250-55610	5	5
114250-02200	10	7	114250-59800	17	2
114250-02210	10	7	114250-66200	15	20
114250-11020	11	16	114250-66550	15	14
114250-11101	11	18	114250-76590	16	12
114250-11113	11	19	114250-76600	11	2
114250-11120	11	24	114250-76610	11	3
114250-11180	11	25	114250-92101	37	1
114250-11290	11	7	114250-92130	37	2
114250-11310	11	5	114260-01453	10	4
114250-11340	11	23	114262-21600	13	6
114250-11460	11	14	114268-13510	12	2
114250-11600	11	22	114270-61520	15	12
114250-11651	11	8	114350-11470	11	13
114250-11900	11	11	114351-78260	18	5
114250-11951	11	4	114362-77019	18	2
114250-12010	12	6	114770-01340	10	12
114250-12200	12	5	114770-61600	15	15
114250-12210	12	11	114770-61610	15	16
114250-12580	8	5	114770-66010	15	17
114250-12580F	8	4	114780-45100	16	4
114250-13200	12	4	114781-21590	13	5
114250-14200	13	13	114789-55500	3	18
114250-14260	13	15	114970-66400	34	1
114250-14450	13	12	11-5531	20	26
114250-21550	13	8	11-5531-1	20	28
114250-22302	14	2	11-5531-2	20	27
114250-32010	15	4	11674728	21	70
114250-32070	15	2		22	68
114250-35070	15	7	11-8303	20	43
114250-35150	10	31	119260-11370	11	9
114250-45211	16	2	124064-55510	5	4

PART NUMBER	FIG.	ITEM	PART NUMBER	FIG.	ITEM
124950-01250	10	11	13230E6744-44	1	35
1250-R-SS-.625-12	21	21		6	18
12878	4	6		21	38
129100-77510	12	13		22	32
129400-77501	12	12	1514	22	51
13218E0493-1249PIC	21	47	1516	21	56
	22	41	160110-02220	10	18
13218E0493-1250PIC	1	38	160120-76940	16	7
13218E0493-1285PIC	21	49	160210-02220	10	1
	22	44	160310-14550	13	2
13218E0493-1287PIC	21	16	160642-21150	13	11
	22	17	160642-21250	13	1
13218E0493-1289PIC	21	55	160710-01760	10	5
	22	49	160710-78710	18	3
13218E0493-1296PIC	21	30	183250-66331	15	19
13218E0493-1375PIC	8	8	183250-66511	15	18
13218E0493-2764PIC	21	77	183266-91690	25	1
13218E0493-2767PIC	21	14	183375-77560	12	9
13218E0493-2769PIC	6	26	1A10	9	5
	21	76	1A11	9	9
	22	52	1B03	9	1
13218E0493-2771PIC	21	58	1B04	9	7
	21	80	1B05	9	2
	22	54	1B06	9	6
13227E6348-9	8	1	1B07	9	3
13230E6743-70	1	40	1B11	9	4
	21	46	1B15	9	8
	22	40	20124SR	22	23
13230E6743-71	21	15	20-271-17MM	20	23
	22	25	20-277-M	7	26
13230E6743-73	21	3	20-TS-0246042	7	18
	22	2	2-2130139C	1	30
13230E6743-74	22	65	22137-080000	15	11
13230E6744-100	1	32	22190-160002	10	17
13230E6744-138	6	28	22252-000190	14	3
13230E6744-41	21	31	22312-030160	15	5
13230E6744-42	7	11	22312-080120	10	6
	21	27	22351-040008	11	21
	22	22			
13230E6744-43	3	3			

PART NUMBER	FIG.	ITEM	PART NUMBER	FIG.	ITEM
22512-040120	13	10	352-0362-00	21	19
24101-062024	13	3		22	11
24101-062050	10	30	390-00000	6	8
24162-152112	10	29	3S1125C3BE3	8	11
24341-000224	15	6	4077-1032-SS-20	21	21
26106-060162	15	8		22	14
26106-060202	15	21	41432	19	7
26106-060552	11	1	41433	19	11
26106-080122	10	25	41435-501	21	50
26106-080352	10	3		22	45
26106-080452	11	6	41446-501	19	10
26106-100302	18	1	414580600	3	7
26216-080182	11	20	414650200	3	12
26226-060142	12	8	42282-2	36	13
26226-060182	10	19	44LC76WDC-10YN	6	25
26226-060222	10	24	44LC76WDC-6YN	21	8
26226-060502	11	15		22	7
26226-060552	11	17	44LC76WDC-7YN	21	8
26366-060002	10	22	44LC76WDC-8YN	21	78
	11	12	47-62-512-50	23	12
	12	10	480.0002	19	8
26366-080002	12	1	4JE	7	17
26476-060142	15	1	4JX1.000	7	20
	16	1	50025900	16	8
	18	4	57558	4	5
26476-060202	18	7	588558-01	1	11
26577-060142	18	6	608-370	19	4
26696-100002	15	13	640-00000	19	13
30451	21	13	640919-1	29	4
31665	19	1		29	6
31666	19	18		30	17
31669	19	17		30	66
331-003	3	11	65.00022	19	2
340	19	3	660-00000	19	12
34068	25	2	714250-11570	11	10
	28	5	714250-23610	14	5
	31	2	714250-23620	14	5
	32	3	714250-23703	14	4
342C698H06	21	68	714250-53101	17	3

PART NUMBER	FIG.	ITEM	PART NUMBER	FIG.	ITEM
714250-61500	15	10	88-20564-18	6	27
714260-76821	16	10		21	5
714270-11660	11	26		22	4
714288-21700	13	9	88-20564-19	21	62
714770-28510	13	4	88-20564-2	1	36
714770-51700	17	1		6	34
714770-61700	15	9		21	37
714771-01560	10	15		22	31
714780-14580	13	14	88-20564-22	7	7
714780-22580	14	1	88-20564-23	1	39
714780-22620	14	1		21	45
714780-22720	14	1		22	39
716FEJSX0000XBS	BULK	16	88-20564-24	7	10
730-008	19	6		21	28
740-008	19	5		22	21
76-0706	33	2	88-20564-25	22	58
	35	4	88-20564-26	21	62
79NE-040	1	8	88-20564-27	21	79
	21	60		22	13
	22	56	88-22336-3	21	63
79NE-058	1	13	88-22790-1	21	39
79NE-066	7	8		22	33
79NE-083	22	61	8917000	33	10
79NM-02	21	65	933-M6X8	16	9
	22	62	95509-01	21	67
79NM-62	22	76		22	64
804	21	32	95-8000	1	10
	22	27	95-8003	7	21
85311	21	24	95-8004	7	22
	22	18	95-8005	1	9
8600-01	1	31	95-8005-99	22	47
871-92V3-000029	22	48	95-8006	22	71
88-20260-25	3	4	95-8006-14	23	6
88-20564-1	3	2	95-8010	22	16
88-20564-14	1	12	95-8011	22	15
88-20564-17	21	11	95-8013	21	20
	22	24		22	12
			95-8014	22	8
			95-8014-2	24	8
			95-8014-4	24	7
			95-8014-5	24	6

PART NUMBER	FIG.	ITEM	PART NUMBER	FIG.	ITEM
95-8015	21	66	95-8028-10	36	5
	22	63	95-8028-11	36	8
95-8016	22	57	95-8028-13	36	7
95-8017	22	72	95-8028-14	36	14
95-8017-5	31	3	95-8028-3	36	3
95-8017-6	31	6	95-8029	1	4
95-8018	21	71	95-8029-13	33	11
	22	69	95-8029-14	33	5
95-8019-1	22	34	95-8029-16	33	8
95-8019-2	21	40	95-8029-3	33	9
95-8019-4	25	3	95-8029-7	33	4
95-8019-5	25	5	95-8030	1	7
95-8021	1	9	95-8030-18	3	15
95-8021-92	21	52	95-8030-20	3	14
95-8022	22	43	95-8030-25	3	10
95-8022-2	27	7	95-8030-27	3	9
95-8022-6	27	12	95-8031	3	6
95-8022-7	27	10	95-8031-4	4	7
95-8022-8	27	8	95-8032	4	3
95-8022-9	27	13	95-8033	4	1
95-8023	22	38	95-8035	3	1
95-8023-10	26	14	95-8036	3	13
95-8023-2	26	10	95-8037	3	23
95-8023-7	26	13	95-8038	3	19
95-8023-8	26	11	95-8039	3	5
95-8023-9	26	12	95-8040	1	6
95-8024-1	21	7	95-8040-8	7	12
	22	6	95-8041	7	13
95-8024-2	1	14	95-8042	7	9
95-8024-3	1	25	95-8043	6	4
95-8024-4	1	27		7	4
95-8024-5	1	25	95-8045	6	22
95-8025	22	60		7	29
95-8026	21	33	95-8047-1	21	43
	22	26		22	37
95-8027	21	53	95-8047-2	22	42
	22	50	95-8048	21	22
95-8028	1	37	95-8049	8	15

PART NUMBER	FIG.	ITEM	PART NUMBER	FIG.	ITEM
95-8050	21	64	95-8056-18-16	30	82
	22	70	95-8056-19	30	85
95-8050-6	28	6	95-8056-19-13	30	87
95-8050-7	28	2	95-8056-19-16	30	88
95-8051	8	9	95-8056-2	30	5
95-8052	8	7	95-8056-20	30	90
95-8053-1	8	3	95-8056-20-6	30	92
95-8054	8	2	95-8056-21	30	94
95-8055	6	1	95-8056-2-13	30	7
	7	1	95-8056-21-4	30	96
95-8055-11	8	18	95-8056-22	30	97
95-8056	22	77	95-8056-22-4	30	99
95-8056-1	30	1	95-8056-23	30	101
95-8056-10	30	43	95-8056-23-4	30	103
95-8056-10-13	30	46	95-8056-24	30	105
95-8056-10-16	30	45	95-8056-24-4	30	107
95-8056-11	30	48	95-8056-3	30	9
95-8056-11-13	30	51	95-8056-3-13	30	11
95-8056-11-16	30	50	95-8056-3-16	30	13
95-8056-1-13	30	3	95-8056-4	30	14
95-8056-12	30	53	95-8056-4-13	30	16
95-8056-12-13	30	56	95-8056-5	30	18
95-8056-12-16	30	55	95-8056-5-13	30	21
95-8056-13	30	58	95-8056-5-16	30	20
95-8056-13-13	30	61	95-8056-6	30	23
95-8056-13-16	30	60	95-8056-6-13	30	26
95-8056-14	30	63	95-8056-6-16	30	25
95-8056-14-13	30	65	95-8056-7	30	28
95-8056-15	30	67	95-8056-7-13	30	31
95-8056-15-13	30	69	95-8056-7-16	30	30
95-8056-16	30	71	95-8056-8	30	33
95-8056-16-13	30	73	95-8056-8-13	30	36
95-8056-16-16	30	74	95-8056-8-16	30	35
95-8056-17	30	76	95-8056-9	30	38
95-8056-17-13	30	78	95-8056-9-13	30	41
95-8056-18	30	80	95-8056-9-16	30	40
95-8056-18-13	30	83	95-8057	8	10

PART NUMBER	FIG.	ITEM	PART NUMBER	FIG.	ITEM
95-8058-1	28	4	95-8139	32	4
95-8060	21	23	95-8141	1	5
95-8061	6	20	95-8141-2	35	3
	7	27	95-8141-5	35	6
95-8064	1	6	95-8141-7	35	8
95-8064-25	6	30	95-8141-8	35	2
95-8064-29	6	24	95-8149	21	61
95-8065	6	15	95-8158-274	21	69
95-8066	21	72		22	67
95-8066-14	23	6	95-8159-1	1	41
95-8067	23	4	95-8159-3	21	10
95-8068	23	3	95-8159-8	1	33
95-8073	6	17		6	29
95-8075	21	48		21	6
95-8075-4	27	2	95-8166	22	5
95-8075-5	27	3		21	75
95-8075-6	27	13	95-8166-1	29	1
95-8076	21	29	95-8166-10	29	38
95-8077	21	9	95-8166-10-12	29	41
95-8077-3	24	2	95-8166-10-13	29	40
95-8077-4	24	3	95-8166-11	29	43
95-8077-5	24	5	95-8166-1-11	29	3
95-8078	21	74	95-8166-11-12	29	46
95-8081	34	2	95-8166-11-13	29	45
95-8082	1	28	95-8166-12	29	48
95-8084	21	44	95-8166-12-12	29	50
95-8084-10	26	14	95-8166-13	29	52
95-8084-6	26	3	95-8166-13-12	29	54
95-8084-7	26	4	95-8166-14	29	55
95-8084-8	26	9	95-8166-14-12	29	57
95-8084-9	26	2	95-8166-15	29	58
95-8085	23	3	95-8166-15-12	29	60
95-8086	23	4	95-8166-16	29	62
95-8087	23	11	95-8166-16-12	29	64
95-8091	23	5	95-8166-17	29	66
95-8127	7	19	95-8166-17-5	29	68
95-8137	4	4	95-8166-18	29	70
			95-8166-18-12	29	72

PART NUMBER	FIG.	ITEM	PART NUMBER	FIG.	ITEM
95-8166-19	29	74	B18212HRCZ060	1	23
95-8166-19-5	29	76		8	13
95-8166-2	29	5	B18212HRCZ080	1	2
95-8166-2-11	29	7		3	24
95-8166-3	29	9		6	11
95-8166-3-11	29	11	B18212HRCZ100	7	24
95-8166-4	29	12		1	19
95-8166-4-11	29	15		6	5
95-8166-4-13	29	14	B18212HRCZN060	7	5
95-8166-5	29	17		3	21
95-8166-5-11	29	19	B18212HRRN030	21	35
95-8166-6	29	21		22	29
95-8166-6-11	29	23	B1821BH025C100N	21	42
95-8166-7	29	24		22	36
95-8166-7-11	29	26	B1821BH025C125N	6	19
95-8166-8	29	28	B1821BH025F075N	1	34
95-8166-8-11	29	30	B1821BH031F075N	6	7
95-8166-8-13	29	32	B1821BH038C250N	7	14
95-8166-9	29	33	B1821BH038C375N	7	16
95-8166-9-11	29	36	B1822BH030R	21	34
95-8166-9-13	29	35		22	28
95-8176	23	1	B1822BH060R	1	24
95-8177	23	9		3	17
95-8178	23	7		8	14
95-8179	23	7	B1822BH080R	1	3
95-8184	21	25		6	10
95-8185	22	19		7	25
9667-1018	2	1	B1822BH100R	1	18
A00864	33	15		6	3
A22-131	21	59		7	3
	22	55	B18231B06012N	8	12
AEM02012	BULK	3		12	3
AEM02022	BULK	2		16	11
AM2S-Z272-1	22	75	B18231B06014N	1	22
AN931-10-14	6	23	B18231B06016N	3	20
ASTMD1056	BULK	1	B18231B06025N	1	29
			B18231B06070N	3	16
			B18231B08016N	1	1
				3	25
			B18231B08020N	1	17
			B18231B08024N	7	23
			B18231B08030N	6	12

PART NUMBER	FIG.	ITEM	PART NUMBER	FIG.	ITEM
B18231B10025NF	1	20	BS4-1801PC15	22	59
	6	13		BSP-32	23
B18231B10040N	6	2	BUSHING	6	32
	7	2		33	7
B18241B080	1	15		36	2
	6	14	CA3102R20-15P-F80	27	1
B18241B100	6	6	CA3102R20-8P-F80	26	1
	7	6	CA3102R24-12P-F80	27	6
B1867BA080550	8	6	CA3108R20-15S-F80	6	33
B1867BC040060	21	41	CA3108R20-8S-F80	33	6
	22	35	CA3108R24-12S-F80	36	1
B1867EC030080	21	36	D02134	6	9
	22	30	D02134-4/5	19	14
BB-8194-08	29	49	D02134-6	19	15
	29	63	DG3M2S-RPC	21	57
	29	71	DG3M6S-RPC	22	53
BB-825-14	27	4	F02A250V1A	21	18
	29	20	22	10	
	29	25	F18356	21	61
	29	29	GFR83FT	21	12
	29	47	HEAD-1	5	1
	29	51	IN4006	28	3
	29	53	L48AE-DEG	8	19
	29	61	LE127-0011-0005	1	21
	29	65	6	31	
	29	73	21	73	
	30	68	22	74	
	30	72	33	3	
	31	4	35	7	
	36	9	36	4	
BB-837-10	26	6	LXF63VB102M16X40LL	31	1
	28	7	M16878/3BJE-9	BULK	9
	29	2	M16878/3BKE-9	BULK	13
	29	8	M16878/3BNL-9	BULK	10
	29	10	M16878/3BRL-9	BULK	14
	29	18	M24243/6-A402H	21	17
	29	22	22	9	
	29	37	23	10	
	29	42	M24243/6-A403H	6	21
	29	56	7	28	
	29	59	23	2	
	30	4			
	30	8			
	30	15			
30	57				
30	62				
30	64				
30	77				

PART NUMBER	FIG.	ITEM	PART NUMBER	FIG.	ITEM
M44A0111-14-0	BULK	19	PV4-12R-E	27	11
M4X0.7X22M	21	26		30	100
	22	20		30	102
M5423/14-06	22	66	PV4-14R-E	27	9
M85049/41-12AWITH				30	95
M85049/41-16AWITH				30	98
MP4847F	33	14		30	106
MR2535L	32	2	PV4-38R-E	36	10
MS16998-28	19	9		30	104
MS25036-109	36	12		30	108
MS25036-115	29	75	PV4-56R	36	11
MS25036-153	30	2	PV8-10R-Q	26	5
	30	6		29	67
	30	10		30	91
MS35489-23	8	16	PV8-38R-Q	26	8
P14-10R	33	16		29	69
P14-6R	21	51		29	77
	22	46		30	93
	24	4	RA40EMBSPECIAL	1	16
	25	4		6	16
	26	7	RB14-12	30	79
	27	5		30	84
	28	1		31	5
	29	13		32	1
	29	31	RB2573	29	16
	29	34		29	27
	29	39		29	73
	29	44		30	22
	30	12		30	27
	30	19		30	32
	30	24		30	37
	30	29		30	42
	30	34		30	47
	30	39		30	52
	30	44		30	70
	30	49	RB-2577F	33	13
	30	54		29	65
	30	59		30	86
	30	75	RH50	36	6
	30	81	RV4LAYS A102A	24	1
	30	89	RV4LAYS A104A	24	9
P14-6RM	19	16	RW-25SBR	BULK	7
P8-14R	33	1	SAE30305	BULK	4
	35	5	SAEJ1508	3	8
P8-56R-Q	33	12	SM-A-57192-53	21	54
	35	1			

PART NUMBER	FIG.	ITEM
ST-301-1/2BLACK	BULK	6
ST-301-1/4WHITE	BULK	15
ST-301-1/8BLACK	BULK	8
ST-301-1-1/2BLACK	BULK	21
ST-301-3/16BLACK	BULK	12
ST-301-3/4BLACK	BULK	22
ST-301-3/64BLACK	BULK	20
ST-301-3/8BLACK	BULK	11
TA97-0030	8	17
TM3S8-C100	22	73

END OF WORK PACKAGE

CHAPTER 8

OPERATOR AND FIELD SUPPORTING INFORMATION

FOR

2 kW MILITARY TACTICAL GENERATOR SETS

MEP-531A

MEP-501A

CHAPTER 8
SUPPORTING INFORMATION

WORK PACKAGE INDEX

<u>Title</u>	<u>WP Sequence No.</u>
References	0157
Introduction for Standard Two-Level Maintenance MAC.....	0158
MAC.....	0159
Components of End Item (COEI) and Basic Issue Items (BII) Lists	0160
Additional Authorization List (AAL)	0161
Expendable and Durable Items List.....	0162
Mandatory Replacement Parts List	0163
Special Packaging Instructions.....	0164
Components and Instructions for Auxiliary Fuel System	0165

OPERATOR AND FIELD MAINTENANCE
2 KW MEP-501A/531A MILITARY TACTICAL GENERATOR SETS
REFERENCES

SCOPE

This work package lists the expendable supplies and materials you will need to operate and maintain the generator set. These items are authorized to you by CTA 50-970, Expendable Items (except Medical, Class V, Repair Parts and Heraldic Items).

PAMPHLETS

(F) AFI 21-101	Maintenance Management of Aircraft
(F) AFI 37-160	Vol. 1, Air Force Publications and Forms Management Programs
(F) TO 00-20 Series	The Maintenance Data Collection System
(F) TO 00-5-1	Air Force Technical Order System
DA PAM 25-30	Consolidated Index of Army Publications and Blank Forms
DA PAM 750-8	The Army Maintenance Management System (TAMMS) Users Manual

FORMS

(F) AFTO Form 22	Technical Order System Publication Improvement Report and Reply
(F) AFTO Form 349	Maintenance Data Collection System
(F) AFTO Form 95	Significant Historical Data
(F) TO 00-35D-54	USAF Deficiency Reporting and Investigating System
DA Form 2028	Recommended Changes to Publications and Blank Forms
DA Form 2404	Equipment Inspection and Maintenance Worksheet
DA Form 2408-9	Equipment Acceptance Report
DA Form 5988E (ULSS)	Equipment Inspection and Maintenance Worksheet
SF 368	Product Quality Deficiency Report

TECHNICAL BULLETINS

(F) TO 35-1-4	Processing and Inspection of Support Equipment for Storage and Shipment
TB 740-97-2	Preservation For USAMECOM Mechanical Equipment For Storage and Shipment

TECHNICAL MANUALS

(F) TO 35-1-3	Corrosion Prevention, Painting, and Marking of USAF Support Equipment
(F) TO 38-1-23	Inspection and Installation of Spark Arresters and Exhaust Purifiers on Non-Aircraft
TM 43-0139	Painting Instructions for Army Material
TM 750-244-3	Destruction of Materiel

FIELD MANUALS

FM 3-11.3	Multi-Service Tactics, Techniques and Procedures for Chemical, Biological, Radiological and Nuclear Contamination Avoidance.
FM 3-11.4	Multi-Service Tactics, Techniques and Procedures for Nuclear, Biological and Chemical Protection.
FM 3-11.5	Multi-Service Tactics, Techniques and Procedures for Chemical, Biological, Radiological and Nuclear Decontamination.
FM 4-25.11	Soldier First Aid
FM 5-424	Theory of Operations Electrical Systems

MISCELLANEOUS PUBLICATIONS

ASME-Y14.38M	Abbreviations For Use on Drawings, and in Specifications, Standards and Technical Documents
ASTM D 3951-98	Packaging, Commercial
CTA 50-970	Expendable Items (Except: Medical, Class V, Repair Parts and Heraldic Items)
CTA 8-100	Accountable Items (Except: Medical, Class V, Repair Parts and Heraldic Items)
MIL-HDBK-729	Corrosion and Corrosion Prevention Metals
MIL-STD-129	Marking for Shipment and Storage

END OF WORK PACKAGE

OPERATOR AND FIELD MAINTENANCE
2 kW MEP-501A/531A MILITARY TACTICAL GENERATOR SETS
INTRODUCTION FOR STANDARD TWO-LEVEL MAINTENANCE MAC

MAINTENANCE ALLOCATION CHART (MAC)

INTRODUCTION

The Army Maintenance System MAC

This introduction provides a general explanation of all maintenance and repair functions authorized at the two maintenance levels under the Two-Level Maintenance System concept.

This MAC (immediately following the introduction) designates overall authority and responsibility for the performance of maintenance functions on the identified end item or component. The application of the maintenance functions to the end item or component shall be consistent with the capacities and capabilities of the designated maintenance levels, which are shown on the MAC in column (4) as:

Field - includes two subcolumns, Crew (C) and Maintainer (F).

Sustainment - includes two subcolumns, Below Depot (H) and Depot (D).

The maintenance to be performed at field and sustainment levels is described as follows:

1. Crew maintenance. The responsibility of a using organization to perform maintenance on its assigned equipment. It normally consists of inspecting, servicing, lubricating, adjusting, and replacing parts, minor assemblies, and subassemblies. The replace function for this level of maintenance is indicated by the letter "C" in the third position of the SMR code. A "C" appearing in the fourth position of the SMR code indicates complete repair is possible at the crew maintenance level.
2. Maintainer maintenance. Maintenance accomplished on a component, accessory, assembly, subassembly, plug-in unit, or other portion either on the system or after it is removed. The replace function for this level of maintenance is indicated by the letter "F" appearing in the third position of the SMR code. An "F" appearing in the fourth position of the SMR code indicates complete repair is possible at the field maintenance level. Items are returned to the user after maintenance is performed at this level.
3. Below depot sustainment. Maintenance accomplished on a component, accessory, assembly, subassembly, plug-in unit, or other portion either on the system or after it is removed. The replace function for this level of maintenance is indicated by the letter "H" appearing in the third position of the SMR code. An "H" appearing in the fourth position of the SMR code indicates complete repair is possible at the below depot sustainment maintenance level. Items are returned to the supply system after maintenance is performed at this level.
4. Depot sustainment. Maintenance accomplished on a component, accessory, assembly, subassembly, plug-in unit, or other portion either on the system or after it is removed. The replace function for this level of maintenance is indicated by the letter "D" or "K" appearing in the third position of the SMR code. Depot sustainment maintenance can be performed by either depot personnel or contractor personnel. A "D" or "K" appearing in the fourth position of the SMR code indicates complete repair is possible at the depot sustainment maintenance level. Items are returned to the supply systems after maintenance is performed at this level.

The tools and test equipment requirements table (immediately following the MAC) lists the tools and test equipment (both special tools and common tool sets) required for each maintenance function as referenced from the MAC.

The remarks table (immediately following the tools and test equipment requirements) contains supplemental instructions and explanatory notes for a particular maintenance function.

Maintenance Functions

Maintenance functions are limited to and defined as follows:

1. Inspect. To determine the serviceability of an item by comparing its physical, mechanical, and/or electrical characteristics with established standards through examination (e.g., by sight, sound, or feel). This includes scheduled inspection and gaugings and evaluation of cannon tubes.

2. **Test.** To verify serviceability by measuring the mechanical, pneumatic, hydraulic, or electrical characteristics of an item and comparing those characteristics with prescribed standards on a scheduled basis, i.e., load testing of lift devices and hydrostatic testing of pressure hoses.
3. **Service.** Operations required periodically to keep an item in proper operating condition; e.g., to clean (includes decontaminate, when required), to preserve, to drain, to paint, or to replenish fuel, lubricants, chemical fluids, or gases. This includes scheduled exercising and purging of recoil mechanisms. The following are examples of service functions:
 - a. **Unpack.** To remove from packing box for service or when required for the performance of maintenance operations.
 - b. **Repack.** To return item to packing box after service and other maintenance operations.
 - c. **Clean.** To rid the item of contamination.
 - d. **Touch up.** To spot paint scratched or blistered surfaces.
 - e. **Mark.** To restore obliterated identification.
4. **Adjust.** To maintain or regulate, within prescribed limits, by bringing into proper position, or by setting the operating characteristics to specified parameters.
5. **Align.** To adjust specified variable elements of an item to bring about optimum or desired performance.
6. **Calibrate.** To determine and cause corrections to be made or to be adjusted on instruments of test, measuring, and diagnostic equipment used in precision measurement. Consists of comparisons of two instruments, one of which is a certified standard of known accuracy, to detect and adjust any discrepancy in the accuracy of the instrument being compared.
7. **Remove/Install.** To remove and install the same item when required to perform service or other maintenance functions. Install may be the act of emplacing, seating, or fixing into position a spare, repair part, or module (component or assembly) in a manner to allow the proper functioning of an equipment or system.
8. **Paint (ammunition only).** To prepare and spray color coats of paint so that the ammunition can be identified and protected. The color indicating primary use is applied, preferably, to the entire exterior surface as the background color of the item. Other markings are to be repainted as original so as to retain proper ammunition identification.
9. **Replace.** To remove an unserviceable item and install a serviceable counterpart in its place "Replace" is authorized by the MAC and assigned maintenance level is shown as the third position code of the Source, Maintenance and Recoverability (SMR) code.
10. **Repair.** The application of maintenance services, including fault location/troubleshooting, removal/installation, disassembly/assembly procedures and maintenance actions to identify troubles and restore serviceability to an item by correcting specific damage, fault, malfunction, or failure in a part, subassembly, module (component or assembly), end item, or system.

NOTE

The following definitions are applicable to the "repair" maintenance function:

Services. Inspect, test, service, adjust, align, calibrate, and/or replace.

Fault location/troubleshooting. The process of investigating and detecting the cause of equipment malfunctioning; the act of isolating a fault within a system or Unit Under Test (UUT).

Disassembly/assembly. The step-by-step breakdown (taking apart) of a spare/functional group coded item to the level of its least component, that is assigned an SMR code for the level of maintenance under consideration (i.e., identified as maintenance significant).

Actions. Welding, grinding, riveting, straightening, facing, machining, and/or resurfacing.

11. **Overhaul.** That maintenance effort (service/action) prescribed to restore an item to a completely serviceable/operational condition as required by maintenance standards in appropriate technical publications. Overhaul is normally the highest degree of maintenance performed by the Army. Overhaul does not normally return an item to like new condition.
12. **Rebuild.** Consists of those services/actions necessary for the restoration of unserviceable equipment to a like new condition in accordance with original manufacturing standards. Rebuild is the highest degree of material maintenance applied to Army equipment. The rebuild operation includes the act of returning to zero those age measurements (e.g., hours/miles) considered in classifying Army equipment/components.

Explanation of Columns in the MAC

Column (1) Group Number. Column (1) lists Functional Group Code (FGC) numbers, the purpose of which is to identify maintenance significant components, assemblies, subassemblies, and modules with the Next Higher Assembly (NHA).

Column (2) Component/Assembly. Column (2) contains the item names of components, assemblies, subassemblies, and modules for which maintenance is authorized.

Column (3) Maintenance Function. Column (3) lists the functions to be performed on the item listed in column (2). (For a detailed explanation of these functions refer to "Maintenance Functions" outlined above).

Column (4) Maintenance Level. Column (4) specifies each level of maintenance authorized to perform each function listed in column (3), by indicating work time required (expressed as manhours in whole hours or decimals) in the appropriate subcolumn. This work time figure represents the active time required to perform that maintenance function at the indicated level of maintenance. If the number or complexity of the tasks within the listed maintenance function varies at different maintenance levels, appropriate work time figures are to be shown for each level. The work time figure represents the average time required to restore an item (assembly, subassembly, component, module, end item, or system) to a serviceable condition under typical field operating conditions. This time includes preparation time (including any necessary disassembly/assembly time), troubleshooting/fault location time, and quality assurance time in addition to the time required to perform the specific tasks identified for the maintenance functions authorized in the MAC. The symbol designations for the various maintenance levels are as follows:

Field:

C Crew maintenance

F Maintainer maintenance

Sustainment:

L Specialized Repair Activity (SRA)

H Below depot maintenance

D Depot maintenance

NOTE

The "L" maintenance level is not included in column (4) of the MAC. Functions to this level of maintenance are identified by work time figure in the "H" column of column (4), and an associated reference code is used in the REMARKS column (6). This code is keyed to the remarks and the SRA complete repair application is explained there.

Column (5) Tools and Equipment Reference Code. Column (5) specifies, by code, those common tool sets (not individual tools), common Test, Measurement and Diagnostic Equipment (TMDE), and special tools, special TMDE and special support equipment required to perform the designated function. Codes are keyed to the entries in the tools and test equipment table.

Column (6) Remarks Code. When applicable, this column contains a letter code, in alphabetical order, which is keyed to the remarks table entries.

Explanation of Columns in the Tools and Test Equipment Requirements

Column (1) - Tool or Test Equipment Reference Code. The tool or test equipment reference code correlates with a code used in column (5) of the MAC.

Column (2) - Maintenance Level. The lowest level of maintenance authorized to use the tool or test equipment.

Column (3) - Nomenclature. Name or identification of the tool or test equipment.

Column (4) - National Stock Number (NSN). The NSN of the tool or test equipment.

Column (5) - Tool Number. The manufacturer's part number.

Explanation of Columns in the Remarks

Column (1) - Remarks Code. The code recorded in column (6) of the MAC.

Column (2) - Remarks. This column lists information pertinent to the maintenance function being performed as indicated in the MAC.

END OF WORK PACKAGE

**OPERATOR AND FIELD MAINTENANCE
2 kW MEP-501A/531A MILITARY TACTICAL GENERATOR SETS
MAC**

Table 1. MAC for 2 kW Military Tactical Generator Sets.

(1) GROUP NUMBER	(2) COMPONENT / ASSEMBLY	(3) MAINTENANCE FUNCTION	(4) MAINTENANCE LEVEL				(5) TOOLS AND EQUIPMENT REF CODE	(6) REMARK CODES
			FIELD		SUSTAINMENT			
			CREW	MAINTAINER	BELOW DEPOT	DEPOT		
			C	F	H	D		
00	GENERATOR SET, 2 kW (MEP-531A AND 501-A)	Inspect	0.1				3 4, 5, 6, 7 4, 5, 6, 7	A A, M M M M
		Inspect		0.1				
		Test		0.5				
		Adjust		0.5				
01	FRAME ASSEMBLY (531A & 501A)	Repair		1.0				M B, M
		Inspect	0.1					
		Inspect		0.1				
		Repair		0.1		4, 6		
02	FUEL SYSTEM ASSY (531A & 501A)	Replace		1.5			7	
		Inspect	0.1					
		Inspect		0.1				
0201	FUEL TANK ASSY	Adjust		0.2			6	
		Repair		0.2			6	
		Replace		0.3			6	
0202	FUEL FILTER ASSY	Inspect	0.1					
		Inspect		0.1				
		Repair		0.1		6		
		Replace		0.2		6		
03	ENGINE/ ALTERNATOR ASSY, 531A & 501A	Inspect	0.1					C, M
		Inspect		0.1				
		Repair		0.2		4, 5, 6, 7		
		Replace		1.5		4, 7		
0301	ENGINE, DIESEL, MODIFIED	Inspect	0.1				5, 6, 7	M M
		Inspect		0.1			4, 5, 6, 7	
		Repair		0.2		4,		
030101	ENGINE, DIESEL	Repair		1.0				D, M
		Inspect	0.1					
		Inspect		0.1				
		Repair		3.0		4, 5, 6, 7		
03010101	CYLINDER BLOCK INSTALLATION	Replace		1.0			1, 2, 4, 7	M E, M E
		Inspect	0.1					
		Repair		0.2		4, 5, 6, 7		
					2.0		4, 5, 6, 7	

Table 1. MAC for 2 kW Military Tactical Generator Sets. - Continued

(1) GROUP NUMBER	(2) COMPONENT / ASSEMBLY	(3) MAINTENANCE FUNCTION	(4) MAINTENANCE LEVEL				(5) TOOLS AND EQUIPMENT REF CODE	(6) REMARK CODES
			FIELD		SUSTAINMENT			
			CREW	MAINTAINER	BELOW DEPOT	DEPOT		
			C	F	H	D		
03010102	CYLINDER HEAD INSTALLATION	Inspect Adjust Repair Replace		0.1 0.3 2.5		2.0	6 4, 7 4, 7	M F
03010103	AIR CLEANER/ MUFFLER INST	Inspect Repair		0.1 0.3			6	
03010104	CAM/ CRANK/ BAL- ANCE INSTALLATION	Repair Replace				1.0 1.0	4, 7 4, 7	
0301010401	FLYWHEEL AND RING GEAR ASSEMBLY	Repair Replace			1.5	1.5	4, 7 1, 2, 4, 7	
03010105	PISTON AND ROD ASSEMBLY	Repair Replace				1.0 1.5	4, 7 4, 7	
03010106	LUBE OIL PUMP AND GOVERNOR	Inspect Repair				0.2 1.2	4, 5, 6, 7	G
0301010601	REGULATOR BRACKET ASSEMBLY	Inspect Inspect Repair Replace	0.1		0.1 0.2 0.2		5, 6 5, 6	H
03010107	COOLING/ STARTING INSTALLATION	Inspect Inspect Repair	0.1		0.1 0.3		6, 7	
03010108	FUEL INJECTION PUMP/VALVE	Inspect Adjust Repair		0.1 0.2 0.2			6	M
0301010801	FUEL INJECTION PUMP	Inspect Adjust Replace		0.1 0.2 0.2			7 4, 7	M
0301010802	FUEL INJECTOR ASSY	Inspect Replace		0.1 0.2			4, 7	
03010109	STARTING MOTOR AND DYNAMO	Inspect Repair		0.1 0.2			4, 7	M
0301010901	STARTING MOTOR	Inspect Test Replace		0.1 0.2 0.2			3, 4 4, 5, 6, 7	M M I, M
0301010902	DYNAMO ASSEMBLY	Test Replace		0.1 0.3			4 4, 7	
0302	ALTERNATOR ASSY, AC	Inspect Test Repair Repair Replace		0.5 0.5 0.5 1.0		2.0	6 4 4, 5, 6, 7 4, 5, 6, 7 4, 7	M J, M J

Table 1. MAC for 2 kW Military Tactical Generator Sets. - Continued

(1) GROUP NUMBER	(2) COMPONENT / ASSEMBLY	(3) MAINTENANCE FUNCTION	(4) MAINTENANCE LEVEL				(5) TOOLS AND EQUIPMENT REF CODE	(6) REMARK CODES
			FIELD		SUSTAINMENT			
			CREW	MAINTAINER	BELOW DEPOT	DEPOT		
			C	F	H	D		
0303	ALTERNATOR ASSY, DC	Inspect Test Repair Replace		0.1 0.5 1	2.0		6 4 4, 7 4, 7	
04	CONTROL PANEL ASSY	Inspect Inspect Test Repair Replace	0.1	0.1 0.2 0.3 0.2			3 4, 5, 6, 7 6	M M K, M
0401	PANEL CONSTRUCTION	Inspect Repair		0.1 0.2			5, 6	
0402	POTENTIOMETER	Inspect Test Repair Replace		0.1 0.2 0.2 0.2			3 5, 6 5, 6	
0403	GENERATOR CONTROL UNIT	Inspect Test Replace		0.1 0.2 0.2			4 7	M
0404	VOLTAGE REGULATOR ASSEMBLY, 531A	Inspect Adjust Test Replace		0.1 0.2 0.2 0.3			4 7	M
0405	VOLTAGE REGULATOR ASSEMBLY, 501A	Inspect Test Replace		0.1 0.2 0.3			4 7	M
0406	DISCHARGE VARISTOR ASSEMBLY	Inspect Test Replace		0.1 0.2 0.2			3 6	
0407	LOW OIL PRESSURE SHUT DOWN SOLENOID ASSEMBLY	Inspect Test Repair Replace		0.1 0.2 0.2 0.5			3 5, 6 5	
0408	WIRING HARNESS, CONTROL PANEL (ENGINE)	Inspect Test Repair Replace		0.1 0.3 0.2 0.3			3 5, 6 6	
0409	WIRING HARNESS, CONTROL PANEL (ALTERNATOR)	Inspect Test Repair Replace		0.1 0.3 0.2 0.3			3 5, 6 6	
0410	FLYWHEEL DIODE ASSY CIRCUIT BREAKER	Inspect Test Replace		0.1 0.2 0.2			3 5, 6 6	
0411	FLYWHEEL DIODE ASSEMBLY TB1-1 TO S2-S	Inspect Test Repair Replace		0.1 0.2 0.2 0.2			3 5, 6 6	

Table 1. MAC for 2 kW Military Tactical Generator Sets. - Continued

(1) GROUP NUMBER	(2) COMPONENT / ASSEMBLY	(3) MAINTENANCE FUNCTION	(4) MAINTENANCE LEVEL				(5) TOOLS AND EQUIPMENT REF CODE	(6) REMARK CODES
			FIELD		SUSTAINMENT			
			CREW	MAINTAINER	BELOW DEPOT	DEPOT		
			C	F	H	D		
0412	ELECTRICAL LEADS	Inspect Test Repair Replace		0.1 0.2 0.2 0.2			3 5, 6 6	
0413	CAPACITOR ASSEMBLY (501A)	Inspect Test Repair Replace		0.1 0.1 0.2 0.1			3 5, 6 6	
0414	TRANSIENT SUPPRESSOR (501A)	Inspect Test Repair Replace		0.1 0.1 0.2 0.2			3 5, 6 6	
0415	EMI FILTER (MEP-531A)	Inspect Test Replace		0.1 0.2 0.2			3 6	L, M M M
05	WIRING HARNESS, ENGINE (531A & 501A)	Inspect Test Repair Replace		0.1 0.2 0.3 0.3			3 5, 6 6	
06	CABLE ASSEMBLY, ENGINE SHUT DOWN (531A & 501A)	Inspect Repair Replace		0.1 0.2 0.2			6 6	
07	LEAD, PREHEATER 531A & 501A)	Inspect Test Repair Replace		0.1 0.2 0.2 0.2			3 5, 6 6	
08	WIRING HARNESS, ALTERNATOR 501A	Inspect Test Repair Replace		0.1 0.2 0.3 0.3			3 5, 6 6	
09	BULK MATERIALS	None		0				

Table 2. Tools and Test Equipment Requirements for 2 kW Military Tactical Generator Sets.

TOOLS OR TEST EQUIPMENT	MAINTENANCE LEVEL	NOMENCLATURE	NATIONAL STOCK NUMBER	TOOL NUMBER
1	F	FLYWHEEL EXTRACTOR	5120-01-416-0424	114250-92130 (OAK42)
2	F	FLYWHEEL TIGHTENING HANDLE	5120-01-415-8266	114250-92101 (OAK42)
3	F	MULTIMETER, DIGITAL	6625-01-139-2512	N60449
4	F, H	TOOL KIT, STANDARD AUTOMOTIVE TOOL SET (SATS) FIELD MAINTENANCE MODULE 1 (FMM1)	4910-01-501-7342	SC4910-95-A82
5	F, H	TOOL KIT, STANDARD AUTOMOTIVE TOOL SET (SATS)	4910-01-490-6453	SC4910-95-A81

Table 2. Tools and Test Equipment Requirements for 2 kW Military Tactical Generator Sets. - Continued

TOOLS OR TEST EQUIPMENT	MAINTENANCE LEVEL	NOMENCLATURE	NATIONAL STOCK NUMBER	TOOL NUMBER
6	F, H	TOOL KIT, GENERAL MECHANIC'S AUTOMOTIVE (GMTK)	5180-01-548-7634	SC5180-95-B48
7	F, H	TOOL KIT, MASTER MECHANIC'S	5180-00-699-5273	SC5180-90-CL-N05

Table 3. Remarks for 2 kW Military Tactical Generator Sets.

REMARK CODES	REMARKS
A	There are two generator set models covered by this Maintenance Allocation Chart. MEP-501A is a 2 kW, 28 VDC Military Tactical Generator Set. MEP-531A is a 2 kW, 120 VAC Military Tactical Generator Set.
B	Repair of the frame at the Service (F) level limited to replacement of damaged threaded inserts.
C	Repair of the engine/alternator at the Service (F) level is limited to the replacement of ground straps, wiring, and data plates, etc.
D	Repair of the diesel engine at the Service (F) level is limited to the replacement of the governor regulator bracket, recoil starter, engine oil strainer, valve cover, and starter (MEP-501A).
E	Repair of the cylinder block installation at the Service (F) level is limited to the replacement of oil fill cap and oil drain plugs.
F	Adjustment of the cylinder head installation consists of checking torque on cylinder head nuts and valve adjustment.
G	Repair of the lube oil pump and governor at the Service (F) level is limited to the replacement of the regulator bracket and external lever.
H	Repair of the regulator bracket is limited to the replacement of a spring.
I	Replace starter motor at Field (F) level for MEP-531A since the alternator must also be removed.
J	Repair of the alternator at the Service (F) level is limited to the replacement of the brushes (MEP-531A).
K	All control panel repairs can be performed at the Service (F) level except for the replacement of the governor control unit and the voltage regulator.
L	EMI filter installed in MEP-531A only.
M	Maintenance performed by MOS 91D or as appropriate to TOE.

END OF WORK PACKAGE

OPERATOR AND FIELD MAINTENANCE

2 kW MEP-501A/531A MILITARY TACTICAL GENERATOR SETS

COMPONENTS OF END ITEM (COEI) AND BASIC ISSUE ITEMS (BII) LISTS

INTRODUCTION

Scope

This work package lists COEI and BII for the 2 kW Military Tactical Generator Sets to help you inventory items for safe and efficient operation of the equipment.

General

The COEI and BII information is divided into the following lists:

Components of End Item (COEI). This list is for information purposes only and is not authority to requisition replacements. These items are part of the 2 kW Military Tactical Generator Sets. As part of the end item, these items must be with the end item whenever it is issued or transferred between property accounts. Items of COEI are removed and separately packaged for transportation or shipment only when necessary. Illustrations are furnished to help you find and identify the items.

Basic Issue Items (BII). These essential items are required to place the 2 kW Military Tactical Generator Sets in operation, operate it, and to do emergency repairs. Although shipped separately packaged, BII must be with the 2 kW Military Tactical Generator Sets during operation and when it is transferred between property accounts. Listing these items is your authority to request/requisition them for replacement based on authorization of the end item by the TOE/MTOE. Illustrations are furnished to help you find and identify the items.

Explanation of Columns in the COEI List and BII List

Column (1) Illus Number. Gives you the number of the item illustrated.

Column (2) National Stock Number (NSN). Identifies the stock number of the item to be used for requisitioning purposes.

Column (3) Description, Part Number/(CAGEC). Identifies the Federal item name (in all capital letters) followed by a minimum description when needed. The stowage location of COEI and BII is also included in this column. The last line below the description is the part number and the Commercial and Government Entity Code (CAGEC) (in parentheses).

Column (4) Usable On Code. When applicable, gives you a code if the item you need is not the same for different models of equipment.

Column (5) U/I. Unit of Issue (U/I) indicates the physical measurement or count of the item as issued per the National Stock Number shown in column (2).

Column (6) Qty Rqr. Indicates the quantity required.

Table 1. Components of End Item List.

(1) Illus Number	(2) National Stock Number (NSN)	(3) Description, Part Number / (CAGEC)	(4) Usable On Code	(5) U/I	(6) Qty Rqr
		Not applicable.			



***ARMY TM 9-6115-673-13&P
AIR FORCE TO 35C2-3-512-1**

TECHNICAL MANUAL
OPERATOR AND FIELD MAINTENANCE MANUAL
(INCLUDING REPAIR PARTS AND SPECIAL TOOLS LIST)
FOR
2 kW MILITARY TACTICAL GENERATOR SETS
120 VAC, 60 Hz
MEP-531A (DEWEY)
(NSN: 6115-01-435-1565) (EIC: GE2)

120 VAC, 60 Hz
MECHRON
(NSN: 6115-21-912-0393) (EIC: VIB)

28 VDC
MEP-501A (DEWEY)
(NSN: 6115-01-435-1567) (EIC: LTJ)

28 VDC
MECHRON
(NSN: 6115-21-912-0392) (EIC: VBD)

A cutaway diagram of a generator set, showing the internal mechanical and electrical components. The generator is mounted on a metal frame. A line labeled '2' points to the right side of the manual cover.

***SUPERSEURE NOTICE** - This manual supersedes TM 9-6115-673-13&P, AND TO 35C2-3-512-1, dated 15 September 2002. Date of issue for the revised manual is: 30 June 2010.

DISTRIBUTION STATEMENT A - Approved for public release; distribution is unlimited.

HEADQUARTERS, DEPARTMENTS OF THE ARMY AND AIR FORCE

30 June 2010

Figure 1. Technical Manual TM 9-6115-673-13&P and Ground Rod Electrical Equipment.

Table 2. Basic Issue Items List.

(1) Illus Number	(2) National Stock Number (NSN)	(3) Description, Part Number / (CAGEC)	(4) Usable On Code	(5) U/I	(6) Qty Rqr
1	5975-00-878-3791	GROUND ROD, ELECTRICAL EQUIPMENT		EA	1
2		TECHNICAL MANUAL TM 9-6115-673-13&P		EA	2

END OF WORK PACKAGE

OPERATOR AND FIELD MAINTENANCE
2 kW MEP-501A/531A MILITARY TACTICAL GENERATOR SETS
ADDITIONAL AUTHORIZATION LIST (AAL)

INTRODUCTION

Scope

This work package lists additional items you are authorized for the support of the 2 kW Military Tactical Generator Sets.

General

This list identifies items that do not have to accompany the 2 kW Military Tactical Generator Sets and that do not have to be turned in with it. These items are all authorized to you by CTA, MTOE, TDA, or JTA.

Explanation of Entries in the AAL

Column (1) National Stock Number (NSN). Identifies the stock number of the item to be used for requisitioning purposes.

Column (2) Description, Part Number/(CAGEC). Identifies the Federal item name (in all capital letters) followed by a minimum description when needed. The last line below the description is the part number and the Commercial and Government Entity Code (CAGEC) (in parentheses).

Column (3) Usable On Code. When applicable, gives you a code if the item you need is not the same for different models of equipment.

Column (4) U/I. Unit of Issue (U/I) indicates the physical measurement or count of the item as issued per the National Stock Number shown in column (1).

Column (5) Qty Recm. Indicates the quantity recommended.

Table 1. Additional Authorization List.

(1) National Stock Number (NSN)	(2) Description, Part Number / (CAGEC)	(3) Usable On Code	(4) U/I	(5) Qty Recm
2910-00-066-1235	ADAPTER, CONTAINER 13211E7541 (97403)		EA	1
7240-00-222-3088	CAN, GASOLINE, MILITARY 42-D-1280 (80372)		EA	1
4210-00-270-4512	EXTINGUISHER, FIRE, CARBON DIOXIDE O-E-910 (81348)		EA	1
6545-00-912-1200	KIT, FIRST AID		EA	1
5120-01-013-1676	SLIDE HAMMER, GROUND 13226E7741 (97403)		EA	1
7240-00-177-6154	SPOUT, CAN, FLEXIBLE A-A-59592 (81349)		EA	1

END OF WORK PACKAGE

OPERATOR AND FIELD MAINTENANCE
2 kW MEP-501A/531A MILITARY TACTICAL GENERATOR SETS
EXPENDABLE AND DURABLE ITEMS LIST

EXPENDABLE AND DURABLE ITEMS LIST

Scope

This work package lists expendable and durable items that you will need to operate and maintain the (enter equipment/end item name). This list is for information only and is not authority to requisition the listed items. These items are authorized to you by CTA 50-970, Expendable/Durable Items (Except Medical, Class V Repair Parts, and Heraldic Items), CTA 50-909, Field and Garrison Furnishings and Equipment or CTA 8-100, Army Medical Department Expendable/Durable Items.

Explanation of Columns in the Expendable/Durable Items List

Column (1) Item No. This number is assigned to the entry in the list and is referenced in the narrative instructions to identify the item (e.g., Use brake fluid (WP 0098, item 5)).

Column (2) Level. This column identifies the lowest level of maintenance that requires the listed item (include as applicable: C = Crew, O = AMC, F = Maintainer or ASB, H = BelowDepot or TASMG, D = Depot).

Column (3) National Stock Number (NSN). This is the NSN assigned to the item which you can use to requisition it.

Column (4) Item Name, Description, Part Number/(CAGEC). This column provides the other information you need to identify the item. The last line below the description is the part number and the Commercial and Government Entity Code (CAGEC) (in parentheses).

Column (5) U/I. Unit of Issue (U/I) code shows the physical measurement or count of an item, such as gallon, dozen, gross, etc.

Table 1. Expendable and Durable Items List.

(1) Item No.	(2) Level	(3) National Stock Number (NSN)	(4) Item Name, Description, Part Number / (CAGEC)	(5) U/I
1	F	8040-00-273-8697	ADHESIVE C-111	BT
2	F	8040-00-181-8374	ADHESIVE CONTACT R-27780	PT
3	F	8020-00-721-9657	BRUSH, PAINT, 2-IN. WIDE	EA
4	F	7920-01-338-3329	CLOTH, CLEANING TX-1250	EA
5	F		COMPOUND, CORROSION PREVENTIVE	
6	F		COMPOUND, INSULATING, ELECTRICAL, DOW CORNING 4	BT
7	F	8030-01-025-1692	COMPOUND, LOCKING, LOCTITE 242	BT
8	F		COMPOUND, RETAINING 62040	BT
9	F		DYE PENETRANT	BT

Table 1. Expendable and Durable Items List. - Continued

(1) Item No.	(2) Level	(3) National Stock Number (NSN)	(4) Item Name, Description, Part Number / (CAGEC)	(5) U/I
10	F	8040-01-137-8418	EPOXY, TWO-PART, EA9330	KT
11	F	5210-00-640-6178	GAUGE, BEARING CLEAR, PLASTIGAGEPR1	BX
12	F	9150-00-663-1770	GREASE, GENERAL PURPOSE, 6 LB CAN 630AA	LB
13	F		ISOPROPYL ALCOHOL, TT-I-735A	OZ
14	F		LUBRICATING OIL, MIL-PRF-46167 [-40 °to 0 °F (-40 °to -18 °C)] 0W30	QT
15	F	9150-00-152-4117	LUBRICATING OIL, MIL-PRF-2104 [0 °to 120 °F (-18 °to 49 °C)] 15W40	QT
16	F	8010-01-229-7546	PAINT, GREEN (COLOR #383) MIL-C-53039	QT
17	F	5330-00-543-3600	PAPER, ABRASIVE, ALOXGRIT 80	SH
18	F		PAPER, ABRASIVE, 500-600 GRIT	SH
19	F		SEALANT, (TEFLON THREAD TAPE) M6389	OZ
20	F		SOLVENT, CLEANING, APPROVED	OZ
21	F		THREAD SEALANT, PERMATEx 2B	CN
22	F		WIRE, STEEL 0.019 IN.	FT

END OF WORK PACKAGE

OPERATOR AND FIELD MAINTENANCE
2 kW MEP-501A/531A MILITARY TACTICAL GENERATOR SETS
MANDATORY REPLACEMENT PARTS LIST

2 kW MILITARY TACTICAL GENERATOR SETS - MANDATORY REPLACEMENT PARTS

The following list consists of parts that are automatically replaced when removed while performing a maintenance task.

Table 1. Mandatory Replacement Parts List.

Item No.	Part Number / (CAGEC)	National Stock Number (NSN)	Nomenclature	Qty
1	31665	3130-01-467-7863	Bearing, AC Alternator	1
2	11-3303-1	3110-01-419-3167	Bearing, Front, DC Alternator	1
3	11-1072-1		Bearing, Rear, DC Alternator	1
4	390-00000	5910-01-319-8589	C-Washer, AC Alternator	1
5	114250-12580F	2940-01-421-1106	Filter Element, Air	1
6	114250-55510	2910-01-420-9067	Filter Element, Fuel	1
7	95-8053-1		Gasket, Air Filter	2
8	114250-12200	5330-01-324-8287	Gasket, Air Intake Pipe	1
9	95-8047-2		Gasket, Alternator Harness, Ctrl. Panel	1
10	114250-01412	5330-01-324-8287	Gasket, Crankcase Cover	1
11	114770-01340	5330-01-419-5479	Gasket, Cylinder Head	1
12	95-8047-1		Gasket, Engine Harness, Ctrl. Panel	1
13	102103-55520	5331-01-431-7566	Gasket, Fuel Filter	1
14	102103-55520	5330-01-326-8021	Gasket, Fuel Injector	1
15	114250-13200	5330-01-326-4780	Gasket, Muffler	1
16	114250-11310	5330-01-326-8022	Gasket, Valve Cover	1
17	114250-01380	5330-01-328-4148	O-ring, Cylinder Head	1
18	24341-000224	5330-01-326-8017	O-ring, Oil Strainer	1
19	103338-32570	5330-01-324-8279	Preformed Packing, Oil Pump Cover	1
20	160110-02220	5330-01-324-8254	Seal, Crankshaft, Front	1
21	160210-02220	5330-01-324-8253	Seal, Crankshaft, Rear	1
22	114250-11340	5330-01-324-8831	Seal, Valve Stem	2

END OF WORK PACKAGE

OPERATOR AND FIELD MAINTENANCE
2 kW MEP-501A/531A MILITARY TACTICAL GENERATOR SETS
SPECIAL PACKAGING INSTRUCTIONS

SPECIAL PACKAGING INSTRUCTIONS

This work package contains special packaging instructions for the 2 kW generator sets.

SPECIAL PACKAGING INSTRUCTION (MIL-STD-2073)				CODE IDENT 30554	SPI NO.	
PART OR DRAWING NO. 95-531			NATIONAL STOCK NO. 6115-01-435-1565		DATE 98150	REVISION 0
QUP 001	ICQ 000	UNIT PACK WT 163.8 lbs (approx)	UNIT PACK CUBE 5.93	UNIT PACK SIZE 29.5 x 16 x 21.7		SHEET 1 OF 2
<p><u>Preservation:</u> Generator Set: MIL-P-116, Method IIb Engine: MIL-E-10062, Level A, Type II, Method II</p> <p><u>Cleaning:</u> MIL-P-116</p> <p><u>Drying:</u> MIL-P-116</p> <p><u>Packing:</u> Level A: MIL-STD-2073-1A</p> <p><u>Marking:</u> MIL-ST-129</p>				STEPS	REQD	DESCRIPTION
				1		Preserve generator set IAW MIL-P-116, IIb
				2		Preserve diesel engine IAW MIL-E-10062, A, II, II
				3		Tape air intake and exhaust openings.
				4		Tape PPP-T-60, IV
						Container; PPP-B-601, overseas-type (inside diameter) 29.5 x 16 x 21.7 inches.

NOTES:

1. Seal air intake and exhaust openings with tape PPP-T-60, Type IV (or MIL-T-22085, Type II).
2. An internal-type humidity indicator shall be required as specified in MIL-P-116.
3. Generator set shall be packed in a close fitting plywood box conforming to PPP-B-601, overseas-type. Metal strapping shall be zinc-coated.

DD FORM 2169
1 JAN 79

Figure 1. Special Packaging Instructions, MEP-531A (Sheet 1 of 2).

SPECIAL PACKAGING INSTRUCTION (MIL-STD-2073)		CODE IDENT 30554		SPI NO.	
(CONTINUATION SHEET)					
PART OR DRAWING NO. 95-531		NATIONAL STOCK NO. 6115-01-435-1565		DATE 98150	REVISION 0
SHEET 2 OF 2					

DD FORM 2169
1 JAN 79

Figure 1. Special Packaging Instructions, MEP-531A (Sheet 2 of 2).

SPECIAL PACKAGING INSTRUCTION (MIL-STD-2073)				CODE IDENT 30554		SPI NO.	
PART OR DRAWING NO. 95-501			NATIONAL STOCK NO. 6115-01-435-1567			DATE 98150	REVISION 0
QUP 001	ICQ 000	UNIT PACK WT 147.1 lbs (approx)	UNIT PACK CUBE 5.93	UNIT PACK SIZE 29.5 x 16 x 21.7		SHEET 1 OF 2	
<p>Preservation:</p> <p>Generator Set: MIL-P-116, Method IIb</p> <p>Engine: MIL-E-10062, Level A, Type II, Method II</p> <p>Cleaning: MIL-P-116</p> <p>Drying: MIL-P-116</p> <p>Packing: Level A: MIL-STD-2073-1A</p> <p>Marking: MIL-ST-129</p>				STEPS	REQD	DESCRIPTION	
				1		Preserve generator set IAW MIL-P-116, IIb	
				2		Preserve diesel engine IAW MIL-E-10062, A, II, II	
				3		Tape air intake and exhaust openings.	
						Tape PPP-T-60, IV	
				4		Container; PPP-B-601, overseas-type (inside diameter) 29.5 x 16 x 21.7 inches.	
<p>NOTES:</p> <ol style="list-style-type: none"> Seal air intake and exhaust openings with tape PPP-T-60, Type IV (or MIL-T-22085, Type II). An internal-type humidity indicator shall be required as specified in MIL-P-116. Generator set shall be packed in a close fitting plywood box conforming to PPP-B-601, overseas-type. Metal strapping shall be zinc-coated. 							

DD FORM 2169
1 JAN 79

Figure 2. Special Packaging Instructions, MEP-501A (Sheet 1 of 2).

SPECIAL PACKAGING INSTRUCTION (MIL-STD-2073)		CODE IDENT 30554		SPI NO.	
		(CONTINUATION SHEET)			
PART OR DRAWING NO. 95-501		NATIONAL STOCK NO. 6115-01-435-1567		DATE 98150	REVISION 0
					SHEET 2 OF 2

Figure 2. Special Packaging Instructions, MEP-501A (Sheet 2 of 2).

END OF WORK PACKAGE

OPERATOR AND FIELD MAINTENANCE
2 kW MEP-501A/531A MILITARY TACTICAL GENERATOR SETS
COMPONENTS AND INSTRUCTIONS FOR AUXILIARY FUEL SYSTEM

SCOPE

This work package lists the components and provides instructions for the installation of the auxiliary fuel system on the 2 kW Military Tactical Generator (MTG) Sets, MEP-531A and MEP-501A.

GENERAL

The current configuration of the 2 kW MTG set lacks the capability to draw fuel from an external source. The set has a 1.6-gallon day tank, which requires the operator to refill the tank every 4.8 hours (when operating at rated load). This auxiliary fuel system will allow the users to extend their mission to over 15 hours of continuous operation at rated load.

ITEM DESCRIPTION

The auxiliary fuel system (see Figure 1) utilizes a standard military 5-gallon fuel can. The can fits on a steel bracket, which can be mounted on the top rail of the set frame, at either the engine or control panel end of the set (see Figure 4). When not in use, the bracket will be stored in a stowed position on top of the set (see Figure 5). The auxiliary fuel system consists of a 5-gallon can fitted with a stinger, 5-gallon can mounting bracket (fabricated in accordance with Figure 3), 3-way valve, 3-way valve mounting bracket (fabricated in accordance with Figure 2), primer bulb, quick disconnect fittings, fuel hoses and hose clamps.

EXPLANATION OF COLUMNS - FIGURE 1

- a. **Item No. [Column (1)].** Indicates the number used to identify items called out in Figure 1.
- b. **Drawing No./Specification [Column (2)].** Indicates the Government drawing number or military specification number that describes the item.
- c. **Description [Column (3)].** Indicates the nomenclature of the item.
- d. **Quantity [Column (4)].** Indicates the quantity of the item used in the breakout shown on Figure 1.
- e. **NSN [Column (5)].** This column lists the NSN by National Item Identification Number (NIIN) sequence. The NIIN consists of the last nine digits of the NSN. When requisitioning items use the complete NSN (13 digits) sequence.
- f. **Part Number [Column (6)].** Indicates the Government drawing part number or the military specification part number that identifies the item.
- g. **MFG [Column (7)].** Indicates the manufacturers of the items.
- h. **MFG P/N [Column (8)].** Indicates the primary number used by the manufacturer (individual, company, firm, corporation, or Government activity), which controls the design and characteristics of the item by means of its engineering drawings, specifications, standards, and inspection requirements to identify an item or range of items.

NOTE

When you use a NSN to requisition an item, the item you receive may have a different part number from the part ordered.

- i. **CAGEC [Column (9)].** This column lists the Commercial and Government Entity Code (CAGEC).

AUXILIARY FUEL SYSTEM INSTRUCTIONS

WARNING

The fuels in this generator set are flammable. Do not smoke or use open flames when performing maintenance. Do not service or drain the fuel system while open flames are present. Flames and explosion could result in severe personal injury or death. Use a container or cloth to catch any excess fuel to prevent spilling over engine components. Be sure to properly dispose of diesel fuel and diesel fuel soaked cloths.

CAUTION

After installing the Auxiliary Fuel System, check to ensure none of the hoses come into contact with sharp edges. It may be necessary to reorient the hose clamps.

CAUTION

When installing the fuel primer bulb assembly, Item No. 2, into the auxiliary fuel can, do not let the hose come into contact with the muffler or any other potentially hot surfaces.

Fabrication Instructions

1. The following brackets need to be fabricated at a machine shop:
 - a. 3-way valve bracket in accordance with Figure 2.
 - b. Fuel can bracket in accordance with Figure 3.

Tools Required for Pre-assembly, Assembly, and Disassembly

2. The following tools are required for pre-assembly, assembly, and disassembly of the Auxiliary Fuel System:
 - a. Hose cutter.
 - b. Two (2) crescent wrenches.
 - c. Measuring device.
 - d. Screwdriver.

Pre-assembly Instructions

3. Using a 4-1/2-foot (54-inch) section of 5/16-inch ID hose, cut four (4) sections of hose in the following lengths:
 - a. One (1) 2.0-inch length (Item 6).
 - b. One (1) 29.0-inch length (Item 8).
 - c. One (1) 9.0-inch length (Item 9).
 - d. One (1) 8.0-inch length (Item 16).
4. Before assembling fittings, coat all male pipe threads with sealing compound, Item 24. Pre-assemble 3-way valve, Item 11, with the following items: male pipe to hose straight adapter, Item 14; male pipe to hose elbow, Item 10; male pipe to male pipe elbow, Item 13, male quick disconnect to female pipe fitting, Item 4, and dust cap, Item 26; and two (2) hoses, Item 9 and 16. Looking at the handle side of the 3-way valve, with screw holes facing down, install the fittings as follows:
 - a. Install male pipe to hose straight adapter, Item 14, into the left side port of the 3-way valve.
 - b. Install male pipe to hose elbow, Item 10, into the center port of the 3-way valve.
 - c. Install male pipe to male pipe elbow, Item 13, into the right side port of the 3-way valve. Attach dust cap, Item 26, onto elbow, Item 13, and install male quick disconnect to female pipe fitting, Item 4, onto elbow, Item 13.
 - d. Slide one hose clamp, Item 5, onto hose, Item 16. Slide one end of hose, Item 16, onto male pipe to hose straight adapter, Item 14. Slide the hose clamp, Item 5, over the straight adapter, Item 14, and tighten.

- e. Slide one hose clamp, Item 5, onto hose, Item 9. Slide one end of hose, Item 9, onto male pipe to hose elbow, Item 10. Slide the hose clamp, Item 5, over the elbow, Item 10, and tighten.
5. Remove the existing pipe to tube adapter from the fuel drum adapter assembly, Item 1, and replace it with male to male pipe nipple, Item 12. Discard the pipe to tube adapter. Attach dust cap, Item 26, onto nipple, Item 12, and install male quick disconnect to female pipe fitting, Item 4, onto nipple, Item 12.
6. Pre-assemble fuel primer bulb assembly, Item 2, as follows:
 - a. Slide two (2) hose clamps, Item 5, onto hose, Item 6. Attach one end of hose, Item 6, to the suction side of the fuel primer bulb, Item 7. Slide one hose clamp, Item 5, over the primer bulb fitting and tighten. Insert male pipe to hose straight adapter, Item 14, in the free end of hose, Item 6. Slide remaining hose clamp, Item 5, over straight adapter, Item 14, and tighten. Attach dust plug, Item 15, onto straight adapter, Item 14, and install female quick disconnect to female pipe thread half coupling, Item 3, onto straight adapter, Item 14.
 - b. Slide two (2) hose clamps, Item 5, onto hose, Item 8. Attach one end of hose, Item 8, to the pressure side of the fuel primer bulb, Item 7. Slide one hose clamp, Item 5, over the primer bulb fitting and tighten. Insert male pipe to hose straight adapter, Item 14, in the free end of hose, Item 8. Slide remaining hose clamp, Item 5, over straight adapter, Item 14, and tighten. Attach dust plug, Item 15, onto straight adapter, Item 14, and install female quick disconnect to female pipe thread half coupling, Item 3, onto straight adapter, Item 14.
7. Using a suitable container (2-gallon capacity), drain the set fuel tank by opening the drain cock (WP 0120, Figure 4, Item 6) on the bottom of the tank.
8. Turn the handle on the fuel filter (WP 0119, Figure 3, Item 18) to the up position to close the filter. Disconnect the fuel supply hose (WP 0119, Figure 3, Item 10) from the input side of the fuel filter by loosening hose clamp (WP 0119, Figure 3, Item 11).
9. Remove the elbow barb fitting and hose (WP 0119, Figure 3, Items 12 and 10) from the bottom of the fuel tank (WP 0119, Figure 3, Item 6). Remove the rubber bushing (WP 0120, Figure 4, Item 4) from the tank and discard. Loosen the hose clamp (WP 0119, Figure 3, Item 11) on the elbow barb fitting, remove the hose and discard it. Retain the elbow barb fitting.
10. Attach the 3-way valve assembly to the bracket, Item 17, using two (2) each machine screws, lock-spring washers, flat washers, and machine nuts (Items 18, 19, 20, and 21). The order of assembly should be screw, bracket, 3-way valve assembly, flat washer, lock-spring washer, and machine nut.
11. Facing the fuel tank side of the generator set, disassemble the capscrew, plain washer, lockspring washers (2), and hex nuts (2) attaching the ground braids (2) to the generator cross member (WP 0117, Figure 1, Items 29, 24, 23 (2), 26 (2), 25, and 27). Place the bracket assembly on the cross member so that the bent flange is against the side of the cross member and the 3-way valve assembly faces out. Reassemble the screw, washers, ground braids and nuts through the bracket in their original configuration.
12. Slide one hose clamp, Item 5, onto hose, Item 16. Slide end of hose, Item 16, over the elbow barb fitting (WP 0119, Figure 3, Item 12) from which the supply hose (WP 0119, Figure 3, Item 10) was removed (see Step 9 above). Insert rubber bushing, Item 25, into the bottom of the set tank. Insert elbow barb fitting with hose, Item 16, into the rubber bushing, Item 25. Slide hose clamp, Item 5, over the elbow barb fitting and tighten.
13. Slide one hose clamp, Item 5, onto hose, Item 9. Slide end of hose, Item 9, onto the input fitting of the fuel filter (WP 0119, Figure 3, Item 18). Slide hose clamp, Item 5, over the fuel filter fitting and tighten. Turn the handle on the fuel filter down to open the fuel filter.

CAUTION

After installing the Auxiliary Fuel System, check to ensure none of the hoses come into contact with sharp edges. It may be necessary to reorient the hose clamps.

14. Attach the fuel can bracket, Item 22, to the generator set frame by tilting the bracket so that the ears on the end of the bracket will slide under the top longitudinal members of the set frame. Hook the bracket over the end of the frame.
15. Set the auxiliary fuel can into the bracket and secure with the strap, Item 23.

CAUTION

When installing the fuel primer bulb assembly, Item No. 2, into the auxiliary fuel can, do not let the hose come into contact with the muffler or any other potentially hot surfaces.

16. Complete the installation of the Auxiliary Fuel System as follows:
 - a. Insert the fuel drum adapter assembly, Item 1, into the auxiliary fuel can and secure by depressing the cam handle.
 - b. Attach the quick disconnect half coupling, Item 3, of the suction side of fuel primer bulb assembly, Item 2, to the male quick disconnect, Item 4, on the fuel drum adapter assembly, Item 1.
 - c. Complete the assembly by attaching the quick disconnect half coupling, Item 3, of the pressure side of fuel primer bulb assembly, Item 2, to the male quick disconnect, Item 4, on the 3-way valve assembly. Turn the handle on the 3-way valve, Item 11, to the auxiliary fuel tank position. Prime the system by squeezing the bulb several times. The set is now ready to operate from the auxiliary fuel supply.

Disassembly Instructions

17. To disconnect the auxiliary fuel system, perform the following:
 - a. Turn the handle on the 3-way valve, Item 11, to the closed position.
 - b. Separate the fuel primer bulb assembly, Item 2, from the fuel drum adapter assembly, Item 1, by releasing the quick disconnect coupling. Place the dust cap, Item 26, over the male quick disconnect, Item 4, on the fuel drum adapter assembly, Item 1. Insert the dust plug, Item 15, into the quick disconnect half coupling, Item 3, on the fuel primer bulb assembly, Item 2.
 - c. Separate the fuel primer bulb assembly, Item 2, from the 3-way valve, Item 11, by releasing the quick disconnect coupling. Place the dust cap, Item 26, over the male quick disconnect, Item 4, on the 3-way valve elbow, Item 13. Insert the dust plug, Item 15, into the quick disconnect half coupling, Item 3, on the fuel primer bulb assembly, Item 2.

WARNING

The fuels in this generator set are flammable. Do not smoke or use open flames when performing maintenance. Do not service or drain the fuel system while open flames are present. Flames and explosion could result in severe personal injury or death. Use a container or cloth to catch any excess fuel to prevent spilling over engine components. Be sure to properly dispose of diesel fuel and diesel fuel soaked cloths.

- d. Remove the strap, Item 23, from the auxiliary fuel can.
- e. Remove the auxiliary fuel can from the fuel can bracket, Item 22.
- f. Remove the fuel can bracket, Item 22, by tilting the bracket to release it from the frame.
- g. Store the fuel can bracket, Item 22, as shown in Figure 1, by securing it with the strap, Item 23.
- h. Turn the handle on the 3-way valve, Item 11, to the primary fuel tank position. The set is now ready to operate from the primary fuel tank.

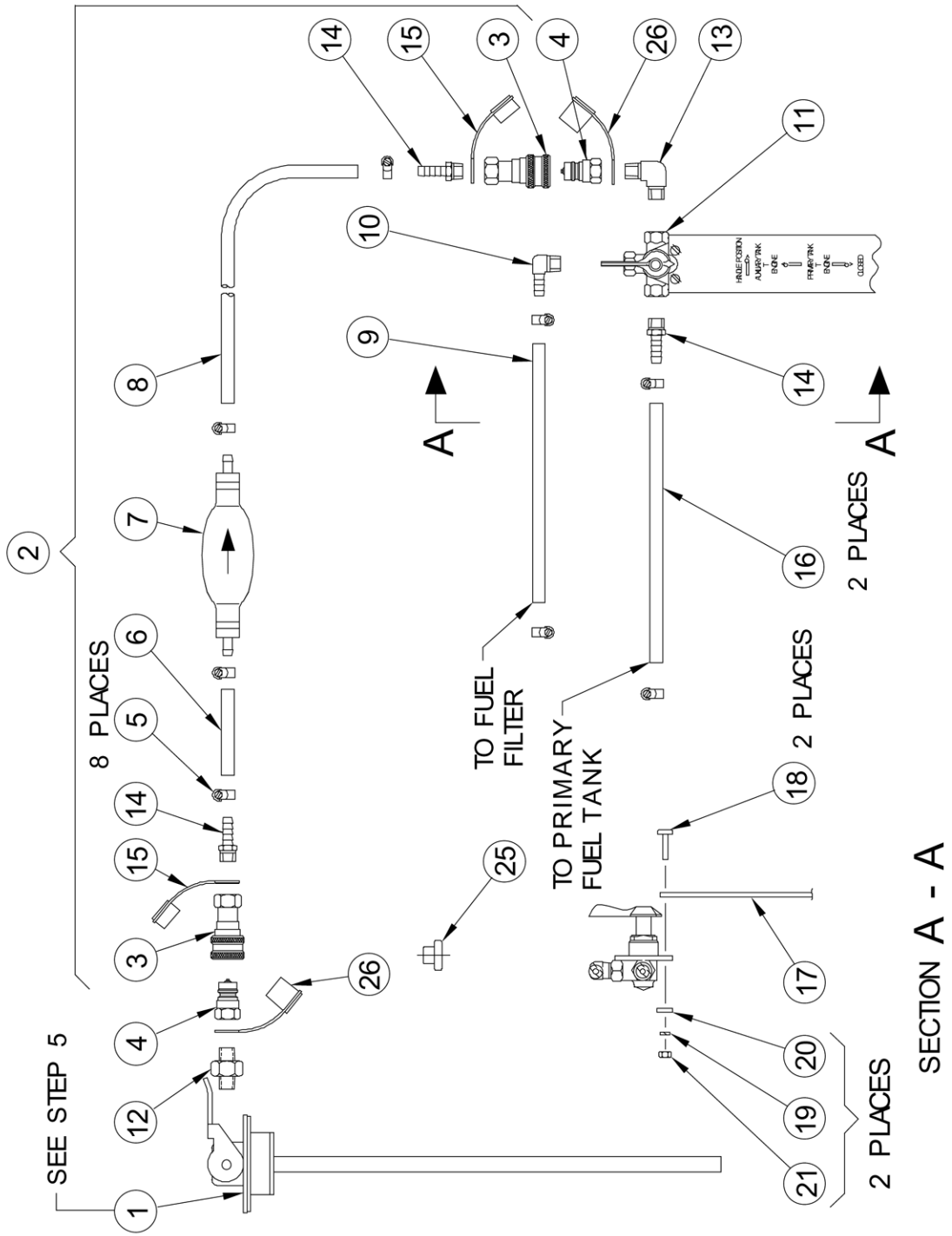

Figure 1. Auxiliary Fuel System (Sheet 1 of 2).

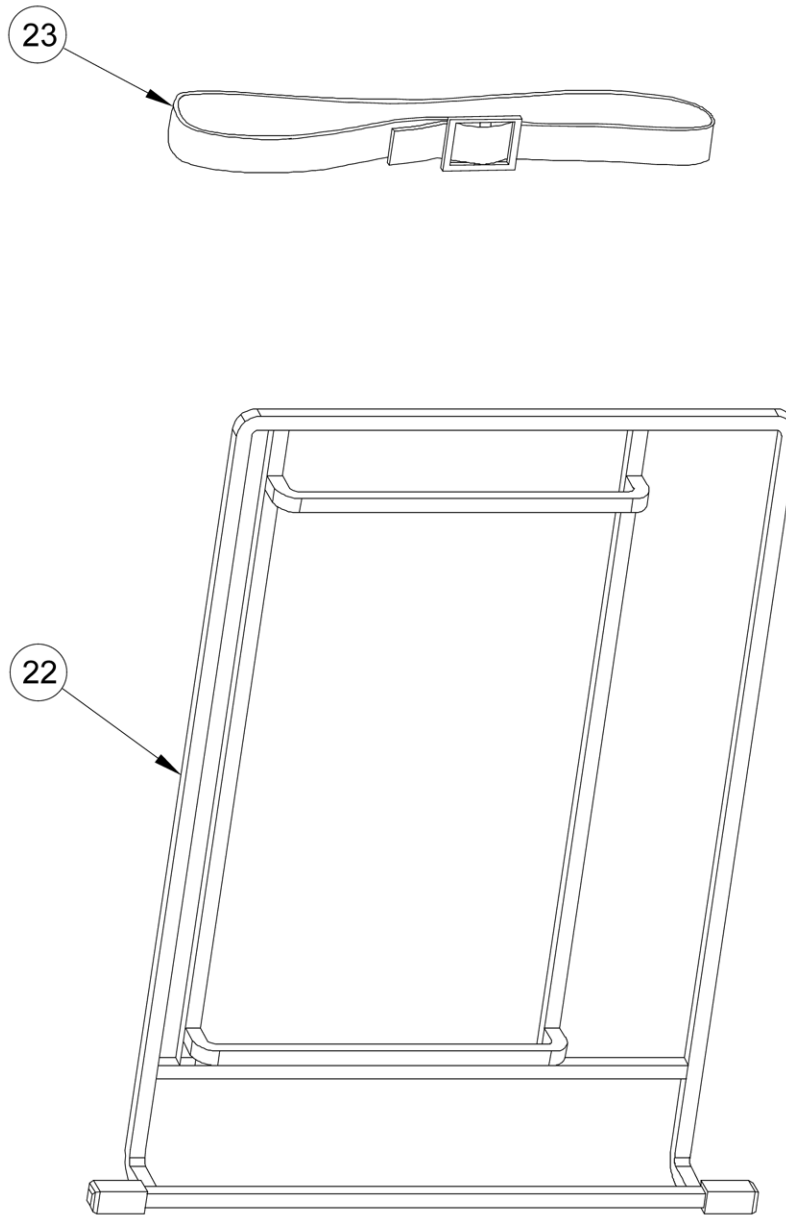

Figure 1. Auxiliary Fuel System (Sheet 2 of 2).

Table 1. Auxiliary Fuel System Components.

ITEM NO.	DRAWING NO./ SPECIFICATION	DESCRIPTION	QTY	NSN	PART NO.	MFG	MFG P/N	CAGEC
1	13211E7541	ADAPTER ASSEMBLY, FUEL DRUM	1	5342-00-066-1235	13211E7541	GATEWAY CABLE COMPANY		61090
2		BULB, PRIMER, FUEL ASSEMBLY	1		CONSISTING OF ITEM NO. 3, 5, 6, 7, 8, 14, AND 15			
3		COUPLING HALF, DISCONNECT FEMALE PIPE THREAD	2	4730-01-184-1683		PARKER-HANNIFIN CORP/QUICK COUPLER DIV	H2-62	97111
4		MALE QUICK DISCONNECT FEMALE PIPE THREAD	2	4730-00-729-7087		PARKER-HANNIFIN CORP/QUICK COUPLER DIV	H2-63	97111
5	SAE J1508	CLAMP, HOSE TYPE M, SIZE 4	8	NONE AVAILABLE				
6		HOSE, 5/16 ID	2.0 IN.	NONE AVAILABLE		AMAZON HOSE AND RUBBER CO.	K3150	3N656
7	13226E1768	BULB, PRIMER, FUEL	1	2805-01-186-7855	13226E1768	OUTBOARD MARINE CORP.	174061	80256
8		HOSE, 5/16 ID	29.0 IN.	NONE AVAILABLE		AMAZON HOSE AND RUBBER CO.	K3150	3N656
9		HOSE, 5/16 ID	9.0 IN.	NONE AVAILABLE		AMAZON HOSE AND RUBBER CO.	K3150	3N656
10		ELBOW, MALE PIPE TO HOSE	1	NONE AVAILABLE		PARKER-HANNIFIN CORP/BRASS PRODUCTS DIV	129HB-5-4	93061
11		3 WAY VALVE	1	NONE AVAILABLE		ANDERSON BRASS CO.	SP2201-B3	70411
12		PIPE NIPPLE MALE TO MALE 1/4-18 NPTF	1	NONE AVAILABLE		PARKER-HANNIFIN CORP/BRASS PLASTICS DIV	1/4 FF	93061
13		ELBOW, MALE TO MALE PIPE 1/4-18 NPTF	1	NONE AVAILABLE		PARKER-HANNIFIN CORP/BRASS PRODUCTS DIV	1/4 CR	93061
14		ADAPTER, STRAIGHT, MALE PIPE TO HOSE	3	4730-00-595-1721		PARKER-HANNIFIN CORP/BRASS PRODUCTS DIV	125HBL-5-4	93061
15		DUST PLUG	2	5340-01-307-2679		PARKER-HANNIFIN CORP/QUICK COUPLER DIV	H2-65M	97111
16		HOSE, 5/16 ID	8.0 IN.	NONE AVAILABLE		AMAZON HOSE AND RUBBER CO.	K3150	3N656
17		BRACKET	1	NONE AVAILABLE	FIGURE 2			
18	13218E0493	SCREW, MACHINE .250-20UNC X .62 L, CRES	2	NONE AVAILABLE	13218E0493-1369			
19	13230E6744	WASHER, LOCK-SPRING, HELICAL .25 ID	2	NONE AVAILABLE	13230E6744-139			
20	88-20033	WASHER, FLAT .25 ID	2	NONE AVAILABLE	88-20033-20C			
21	13218E0320	NUT, MACHINE, FINISHED, HEXAGON .250-20 UNC	2	NONE AVAILABLE	13218E0320-291			
22		BRACKET, FUEL CAN	1	NONE AVAILABLE	FIGURE 3			
23	10897501	STRAP, WEBBING, 1X51	1	5340-00-988-1895	10897521			19207
24	88-20595	SEALING COMPOUND	AR	NONE AVAILABLE	88-20595-1	PERMATEX INDUSTRIAL/ DIV OF LOCTITE CORP	80010	62377
25	95-8137	BUSHING, MOLDED RUBBER	1	NONE AVAILABLE	95-8137	THE DEWEY ELECTRONICS CORP	95-8137	14058
26		DUST CAP	2	5340-01-307-4394		PARKER-HANNIFIN CORP/QUICK COUPLER DIV	H2-66M	97111

NOTE

Note that Item No. corresponds to those numbers in Figure 1.

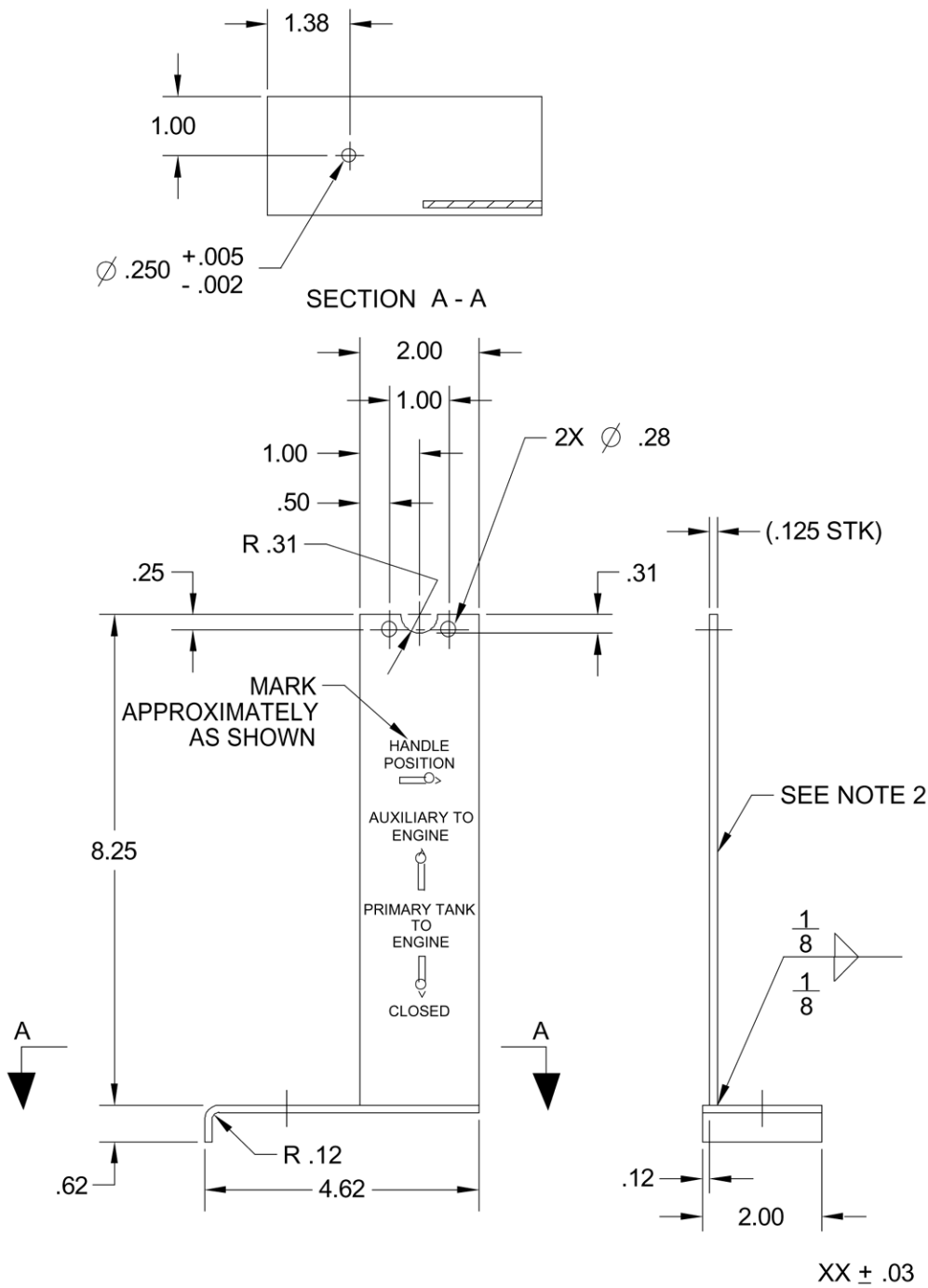

Figure 2. Three Way Valve Bracket.

NOTES TO FIGURE 2:

1. INTERPRET DRAWING IN ACCORDANCE WITH MIL-STD-100.
2. MATERIAL: STRIP, 2.00 X .125, 1018 LOW CARBON STEEL IN ACCORDANCE WITH ASTM A 108.
3. WELDING AND INSPECTION SHALL BE IN ACCORDANCE WITH AWS D1.1. INSPECTION SHALL BE VISUAL. 5 X MAGNIFICATION SHALL BE USED TO EVALUATE ANY AREAS QUESTIONED BY INITIAL VISUAL EXAMINATION.

4. TREAT AND PAINT IN ACCORDANCE WITH MIL-T-704, TYPE F.
5. MARK IN ACCORDANCE WITH MIL-STD-130, METHOD OPTIONAL. LETTERING SHALL BE MINIMUM EXCEPT WHERE NOTED, LETTERING SHALL BE BLACK.

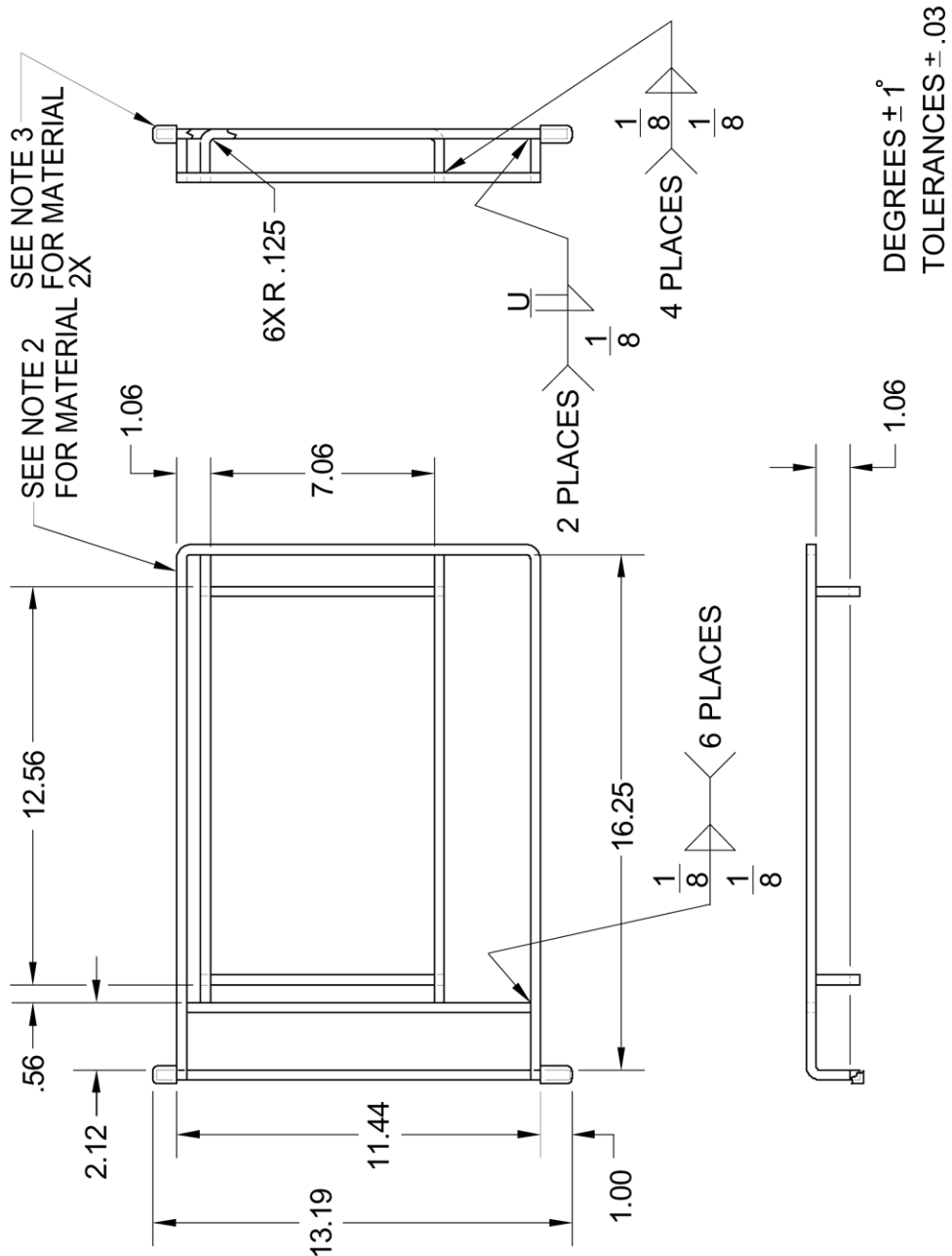

Figure 3. Auxiliary Fuel Tank Bracket.

NOTES TO FIGURE 3:

1. INTERPRET DRAWING IN ACCORDANCE WITH MIL-STD-100.
2. MATERIAL: BAR, SQUARE, .312 STK, 1018 LOW CARBON STEEL, PER ASTM A 108.
3. MATERIAL: INSULATION SLEEVING, ELECTRICAL, 88-20541-13.
4. WELDING AND INSPECTION SHALL BE IN ACCORDANCE WITH AWS D1.1. INSPECTION SHALL BE VISUAL. 5 X MAGNIFICATION SHALL BE USED TO EVALUATE ANY AREAS QUESTIONED BY INITIAL VISUAL EXAMINATION.

5. TREAT AND PAINT IN ACCORDANCE WITH MIL-T-704, TYPE F.
6. IDENTIFY IN ACCORDANCE WITH MIL-STD-130, METHOD OPTIONAL.
7. ALL INSIDE RADII SHALL BE .125.

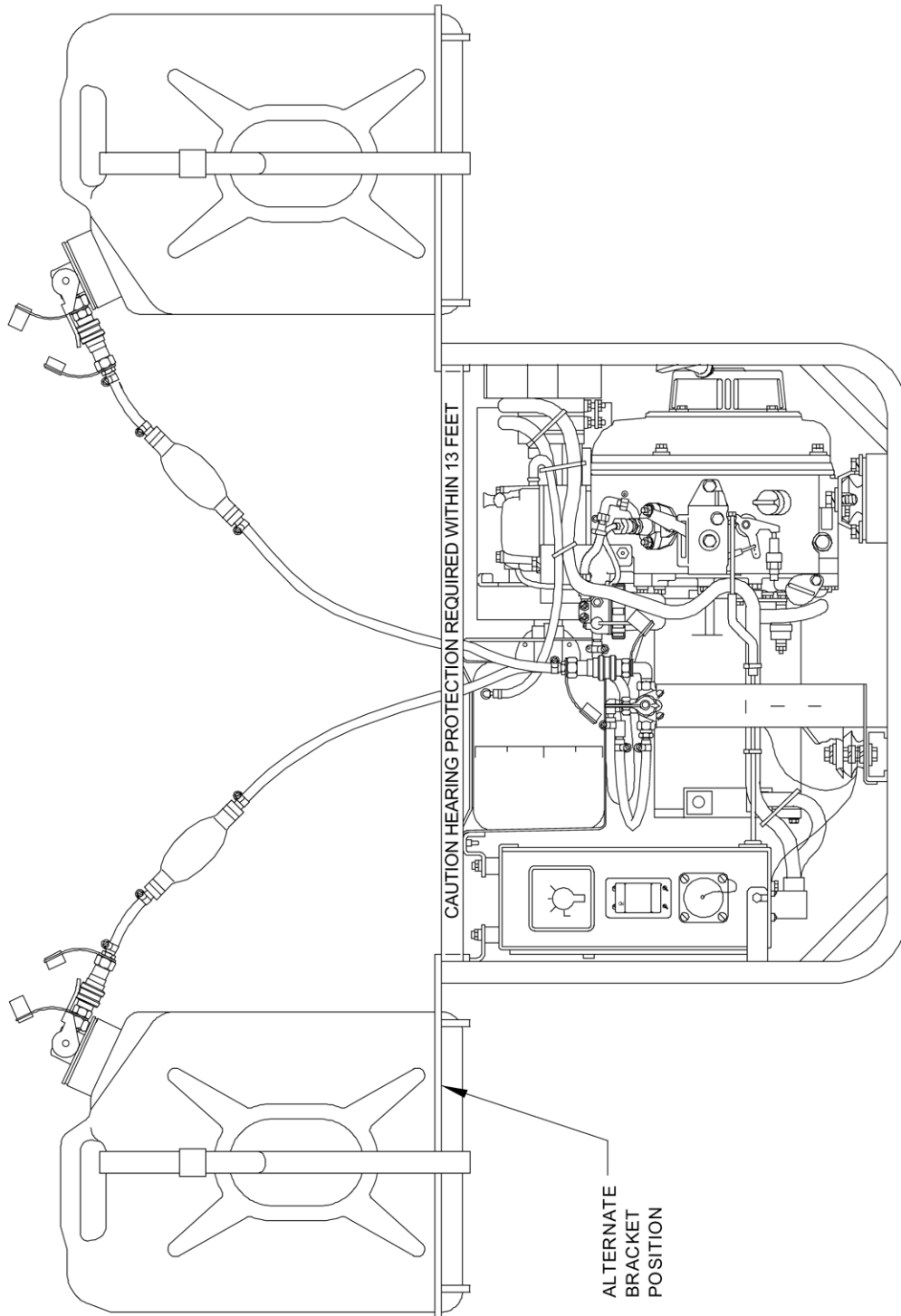

Figure 4. 2 kW Set with Auxiliary Fuel System Installed.

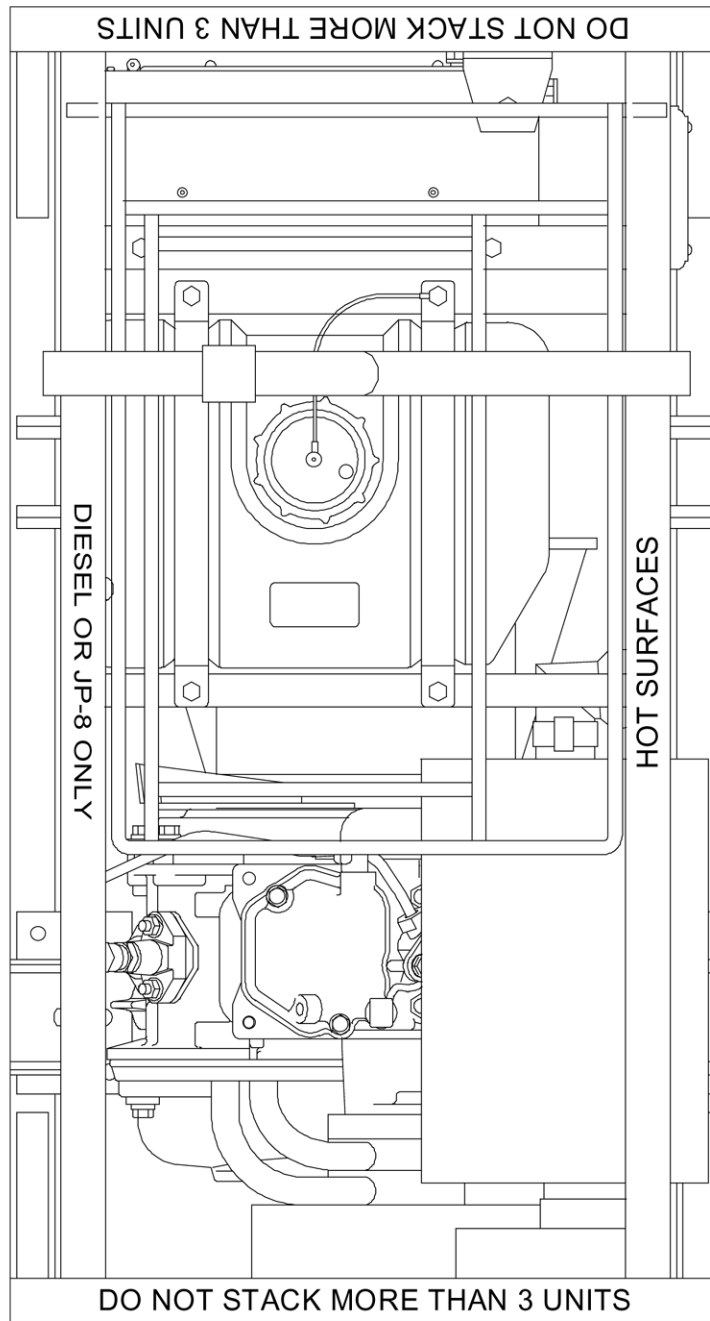

Figure 5. Fuel Can Bracket Shown in the Stowed Position.

END OF WORK PACKAGE

INDEX

<u>Subject</u>	<u>WP Sequence No. - Page No.</u>
%	
% Load Meter: Inspection, Testing, Removal, Installation.....	0038-1
2	
2 kW Deprocessing Checklist.....	0095-1
A	
AC Alternator Assembly (MEP-531A): Removal, Disassembly, Assembly, Inspection, Testing, Installation	0089-1
AC Alternator Bearing (MEP-531A): Removal, Installation	0090-1
Additional Authorization List (AAL).....	0161-1
Air Filter Element Replacement: Removal, Cleaning, Installation	0018-1
Air Intake Heating Elements and Pipe: Removal, Inspection, Testing, Installation	0063-1
Air Intake System Components: Removal, Inspection, Installation	0030-1
Alternator Brushes Inspection (MEP-531A): Removal, Inspection, Installation.....	0020-1
Alternator Flexible Coupling Inspection (MEP-501A): Removal, Inspection, Installation	0021-1
Alternator Resilient Mount Replacement (MEP-501A): Removal, Installation.....	0024-1
Alternator Resilient Mount Replacement (MEP-531A): Removal, Installation.....	0023-1
Alternator Wiring Harness, Control Panel: Testing, Repair	0077-1
Alternator Wiring Harness (MEP-501A): Inspection, Testing, Removal, Repair, Installation	0071-1
Alternator Wiring Harness and Gasket, Control Panel: Inspection, Testing, Removal, Repair, Installation	0056-1
B	
Bulk Items.....	0153-1
C	
Capacitor (MEP-501A): Inspection, Removal, Testing, Repair, Installation	0042-1
Capacitor Assembly (P/N: 95-8017).....	0102-1
Components and Instructions for Auxiliary Fuel System	0165-1
Components of End Item (COEI) and Basic Issue Items (BII) Lists	0160-1
Control Panel Assembly: Inspection, Removal, Repair, Installation.....	0032-1
Cooling Fan Cover: Inspection, Removal, Repair, Installation	0065-1
Crankcase Cover: Removal, Inspection, Installation	0085-1
Critical Safety Items list	0001-4
Cylinder Head Assembly: Removal, Inspection, Installation	0082-1
Cylinder Head Nuts Tightening: Adjustment.....	0025-1
D	
DC Alternator Assembly (MEP-501A): Removal, Disassembly, Inspection, Testing, Assembly, Installation	0091-1
DC Alternator Bearings (MEP-501A): Inspection, Removal, Installation	0092-1

INDEX

<u>Subject</u>	<u>WP Sequence No. - Page No.</u>
DC Alternator Diodes and Capacitors (MEP-501A): Removal, Testing, Installation	0093-1
Description and Use of Operator Controls and Indicators	0004-1
Destruction of Material to Prevent Enemy Use.....	0001-3
Dewey/Mechron Cross-Reference List.....	0096-1
Diesel Engine: Installation, Removal	0079-1
Diesel Engine Electrical Starting System	0003-5
Diesel Engine Wiring Harness, Control Panel: Testing, Repair.....	0076-1
Diesel Engine Wiring Harness and Gasket, Control Panel: Inspection, Testing, Removal, Repair, Installation	0055-1
Discharge Varistor: Inspection, Testing, Removal, Installation	0048-1
Dynamo: Testing, Removal, Inspection, Installation.....	0088-1
E	
Electrical Lead Fabrication for Control Panel	0097-1
Electrical Lead Wire(s) (Typical): Inspection, Testing, Removal, Installation	0057-1
Electromagnetic Interference (EMI) Filter (MEP-531A): Inspection, Removal, Testing, Installation	0059-1
Engine/Alternator Assembly: Removal, Installation.....	0078-1
Engine Air Intake and Exhaust System	0003-2
Engine Oil Strainer: Removal, Cleaning, Installation.....	0067-1
Engine Resilient Mounts Replacement: Removal, Installation	0022-1
Engine Wiring Harness: Inspection, Removal, Disassembly, Repair, Installation	0070-1
Equipment Characteristics, Capabilities, and Features.....	0002-1
Equipment Data.....	0002-3
Equipment Description and Data.....	0002-1
Exhaust System Components: Removal, Cleaning, Installation.....	0031-1
Expendable and Durable Items List.....	0162-1
F	
Field PMCS, Including Lubrication Instructions.....	0016-1
Field PMCS Introduction.....	0015-1
Field Troubleshooting Index	0012-1
Field Troubleshooting Procedures.....	0013-1
Flywheel: Removal, Inspection, Installation.....	0087-1
Flywheel Diode Assembly: Inspection, Testing, Removal, Repair, Installation	0054-1
Flywheel Diode Assembly (P/N: 95-8050).....	0101-1
Flywheel Extractor (P/N: 114250-92130)	0114-1
Flywheel Locking Handle (P/N: 114250-92101)	0113-1
Frame: Inspection, Removal, Repair, Installation.....	0094-1
Fuel Drain Cock: Removal, Installation	0028-1

INDEX

<u>Subject</u>	<u>WP Sequence No. - Page No.</u>
Fuel Filter Assembly: Removal, Inspection, Installation	0027-1
Fuel Filter Element Replacement: Removal, Installation.....	0017-1
Fuel Injection Pump: Removal, Inspection, Installation, Adjustment.....	0084-1
Fuel Injector Replacement: Removal, Inspection, Installation.....	0019-1
Fuel Lines, Clamps, Fittings, Etc.: Removal, Installation.....	0026-1
Fuel System.....	0003-1
Fuel Tank Assembly: Removal, Disassembly, Inspection, Assembly, Installation	0029-1
Fuseholder(s): Inspection, Removal, Installation.....	0044-1
G	
General Information.....	0001-1
Generator Control Circuit.....	0003-11
Generator Control Unit: Inspection, Testing, Removal, Installation.....	0074-1
Generator Voltage Regulation and Output Supply (MEP-501A)	0003-8
Generator Voltage Regulation and Output Supply (MEP-531A)	0003-6
GFCI Receptacle and Receptacle Cover (MEP-531A): Inspection, Testing, Removal, Installation	0046-1
Governor Regulator Bracket: Removal, Inspection, Repair, Installation	0064-1
Ground Strap(s): Inspection, Removal, Installation	0045-1
Ground Stud Terminal: Inspection, Removal, Installation	0073-1
Group 00 Generator Set Assembly, 2 kW (MEP-531A/501A)	0117-1
Group 01 Frame Assembly (MEP-531A/501A)	0118-1
Group 0201 Fuel Tank Assembly	0120-1
Group 0202 Fuel Filter Assembly	0121-1
Group 02 Fuel System Assembly (MEP-531A/501A).....	0119-1
Group 03010101 Cylinder Block Installation	0126-1
Group 03010102 Cylinder Head Installation.....	0127-1
Group 03010103 Air Intake Pipe and Muffler	0128-1
Group 03010104 Cam/Crankshaft/Balancer Installation	0129-1
Group 03010105 Piston and Rod Assembly	0130-1
Group 03010106 Lube Oil Pump and Governor.....	0131-1
Group 03010107 Cooling/Starting Installation.....	0132-1
Group 03010108 Fuel Injection Pump/Injector Installation.....	0133-1
Group 03010109 Starting Motor and Dynamo Installation	0134-1
Group 030101 Diesel Engine Assembly.....	0125-1
Group 0301 Diesel Engine Modified.....	0124-1
Group 0302 AC Alternator Assembly (MEP-531A).....	0135-1
Group 0303 DC Alternator Assembly (MEP-501A)	0136-1
Group 03 Engine Alternator Assembly (MEP-501A)	0123-1

INDEX

<u>Subject</u>	<u>WP Sequence No. - Page No.</u>
Group 03 Engine Alternator Assembly (MEP-531A)	0122-1
Group 0401 Control Panel Constructions (MEP-531A/501A).....	0139-1
Group 0402 Voltage Adjust Potentiometer	0140-1
Group 0407 LOP Shutdown Solenoid Assembly.....	0141-1
Group 0408 Control Panel Engine Wiring Harnesses (MEP-531A/501A)	0142-1
Group 0409 Control Panel Alternator Wiring Harnesses (MEP-531A/501A).....	0143-1
Group 0411 Flywheel Diode Assembly	0144-1
Group 0412 Control Panel Electrical Leads (MEP-501A).....	0146-1
Group 0412 Control Panel Electrical Leads (MEP-531A).....	0145-1
Group 0413 Capacitor Assembly (MEP-501A).....	0147-1
Group 0414 Transient Suppressor Assembly (MEP-501A).....	0148-1
Group 04 Control Panel Assembly (MEP-501A)	0138-1
Group 04 Control Panel Assembly (MEP-531A)	0137-1
Group 05 Engine Wiring Harness (MEP-531A/501A).....	0149-1
Group 06 LOP Engine Shutdown Cable Assembly (MEP-531A/501A)	0150-1
Group 07 Preheater Lead Assembly (MEP-531A/501A)	0151-1
Group 08 Alternator Wiring Harness (MEP-501A).....	0152-1
H	
Hertz Frequency Meter (MEP-531A): Inspection, Testing, Removal, Installation	0036-1
HOURS Meter: Inspection, Testing, Removal, Installation.....	0039-1
I	
Identification and Instruction Plates.....	0005-11
Illustrated List of Manufactured Items Introduction.....	0098-1
Initial Adjustments and Checks	0005-4
Instruction Plate(s): Removal, Installation	0033-1
Instrument Cover: Inspection, Removal, Repair, Installation.....	0034-1
Instrument Fuse (F1): Removal, Inspection, Installation	0011-1
Instrument Panel: Inspection, Removal, Repair, Installation	0035-1
Instrument Shunt (MEP-501A): Inspection, Removal, Testing, Installation.....	0041-1
Intake and Exhaust Valves: Removal, Inspection, Installation, Adjustment	0083-1
Introduction.....	0116-1
Introduction for Standard Two-Level Maintenance MAC.....	0158-1
L	
List of Abbreviations	0001-4
Load Terminal(s) (MEP-501A and Mechron Sets): Inspection, Removal, Installation.....	0050-1
Load Terminal Board (MEP-501A and Mechron Sets): Inspection, Removal, Installation	0052-1
Load Terminal Board Cover (Lug Cover): Inspection, Removal, Repair, Installation	0058-1

INDEX

<u>Subject</u>	<u>WP Sequence No. - Page No.</u>
LOP Shutdown Cable (P/N: 95-8082)	0109-1
LOP Solenoid Valve Assembly (P/N: 95-8019)	0103-1
Low Oil Pressure (LOP) Engine Shutdown Cable: Inspection, Removal, Installation, Adjustment	0062-1
Low Oil Pressure (LOP) Solenoid Assembly: Testing, Removal, Cleaning and Inspection, Repair, Installation	0061-1
Low Oil Pressure (LOP) Switch: Testing, Removal, Installation	0060-1
Low Oil Pressure Protection	0003-13
M	
MAC.....	0159-1
Maintenance Forms, Records and Reports.....	0001-
Mandatory Replacement Parts List	0163-1
N	
NATO Slave Receptacle: Inspection, Removal, Installation.....	0049-1
NSN Index	0155-1
Nuclear, Biological, and Chemical Decontamination Procedures	0006-3
O	
Oil Pump Assembly: Removal, Inspection, Installation	0086-1
ON-OFF Load Circuit Breaker Assembly and Boot: Inspection, Testing, Removal, Installation	0053-1
Operating Procedures	0005-4
Operation Under Unusual Conditions.....	0006-1
Operation Under Usual Conditions.....	0005-1
Operator PMCS, Including Lubrication Instructions.....	0010-1
Operator PMCS Introduction	0009-1
Operator Troubleshooting Index.....	0007-1
Operator Troubleshooting Procedures	0008-1
P	
P/N Index.....	0156-1
Potentiometer, VOLTAGE ADJ. (P/N: 95-8014).....	0100-1
Potentiometer, VOLTAGE ADJ. (P/N: 95-8077).....	0099-1
Preheater Lead, Electrical (P/N: 95-8141).....	0110-1
Preheater Lead: Inspection, Testing, Removal, Repair, Installation.....	0072-1
Preparation for Movement	0005-13
Preparation for Storage or Shipment.....	0001-3
R	
Recoil Starter Assembly: Inspection, Removal, Installation	0066-1
References	0157-1
Reporting Equipment Improvement Recommendations (EIRs).....	0001-3

INDEX

<u>Subject</u>	<u>WP Sequence No. - Page No.</u>
Rocker Arms and Push Rods: Removal, Inspection, Installation	0081-1
S	
Service Upon Receipt.....	0014-1
Special Packaging Instructions.....	0164-1
Special Tools List	0154-1
Speed Control System.....	0003-3
Starter (MEP-531A): Removal, Installation.....	0080-1
Starter Assembly (MEP-501A): Removal, Installation	0069-1
START-PREHEAT/PREHEAT/OFF/START Rotary Switch: Inspection, Testing, Removal, Installation	0047-1
T	
Terminal Board: Inspection, Removal, Testing, Installation	0051-1
Theory of Operation.....	0003-1
Torque Limits.....	0115-1
Transient Suppressor (P/N: 95-8025).....	0112-1
Transient Suppressor Assembly (MEP-501A): Inspection, Removal, Testing, Repair, Installation.....	0043-1
V	
Valve Cover: Removal, Inspection, Installation	0068-1
VOLTAGE ADJ. Potentiometer: Inspection, Testing, Removal	0040-1
Voltage Regulator Assembly: Inspection, Testing, Removal, Installation.....	0075-1
Volts Meter: Inspection, Testing, Removal, Installation.....	0037-1
W	
Wiring Harness, Alternator (P/N: 95-8028).....	0111-1
Wiring Harness, Control Panel (P/N: 95-8022).....	0107-1
Wiring Harness, Control Panel (P/N: 95-8023).....	0105-1
Wiring Harness, Control Panel (P/N: 95-8075).....	0106-1
Wiring Harness, Control Panel (P/N: 95-8084).....	0104-1
Wiring Harness, Engine (P/N: 95-8029)	0108-1

RECOMMENDED CHANGES TO PUBLICATIONS AND BLANK FORMS <small>For use of this form, see AF 85-30, the proponent agency is O&ASA.</small>					Use Part II (reverse) for Repair Parts and Special Tool Lists (RPSTL) and Supply Catalogs/Supply Manuals (SC/SM).		DATE 30 August 2002
TO: (Forward to proponent of publication or form) (Include ZIP Code) Commander, US Army C-E LCMC ATTN: AMSEL-LC-LEO-E-ED Fort Monmouth, NJ 07703-5006					FROM: (Activity and location) (Include ZIP Code) Jane Q. Doe, SFC 1234 Any Street Anytown, AL 34565		
PART I - ALL PUBLICATIONS (EXCEPT RPSTL AND SC/SM) AND BLANK FORMS							
PUBLICATION/FORM NUMBER TM 11-1234-567-14					DATE 16 Sep 2001		TITLE Operator, Field and Sustainment Support Maintenance Manual for Radio, AN/ABC-123
ITEM	PAGE	PARA-GRAPH	LINE	FIGURE NO.	TABLE	RECOMMENDED CHANGES AND REASON	
1	MMR0005 REV 2		3			<small>Test or Corrective Action column should identify a different V/P number</small>	
TYPED NAME, GRADE OR TITLE Jane Q. Doe, SFC				TELEPHONE EXCHANGE/AUTOVON, PLUS EXTENSION 123-4567		SIGNATURE	

EXAMPLE

TO: (Forward to proponent of publication or form) (Include ZIP Code)				FROM: (Activity and location) (Include ZIP Code)			DATE	
PART II- REPAIR PARTS AND SPECIAL TOOL LISTS AND SUPPLY CATALOGS/SUPPLY MANUALS								
PUBLICATION/FORM NUMBER				DATE		TITLE		
PAGE NO.	COLM NO.	LINE NO.	NATIONAL STOCK NUMBER	REFERENCE NO.	FIGURE NO.	ITEM NO.	TOTAL NO. OF MAJOR ITEMS SUPPORTED	RECOMMENDED ACTION
EXAMPLE								
PART III - REMARKS (Any general remarks, criticisms, or suggestions for improvement of publications and blank forms. Additional space may be used if more space is needed.)								
TYPED NAME, GRADE OR TITLE				TELEPHONE EXCHANGE/AUTOVON, PLUS EXTENSION			SIGNATURE	

RECOMMENDED CHANGES TO PUBLICATIONS AND BLANK FORMS <small>For use of this form, see AR 25-30; the proponent agency is OAASA</small>						Use Part II (reverse) for Repair Parts and Special Tool Lists (RPSTL) and Supply Catalogs/Supply Manuals (SC/SM).	DATE
TO: (Forward to proponent of publication or form) (Include ZIP Code)						FROM: (Activity and location) (Include ZIP Code)	
PART I - ALL PUBLICATIONS (EXCEPT RPSTL AND SC/SM) AND BLANK FORMS							
PUBLICATION/FORM NUMBER						DATE	TITLE
ITEM	PAGE	PARA-GRAPH	LINE	FIGURE NO.	TABLE	RECOMMENDED CHANGES AND REASON	
TYPED NAME, GRADE OR TITLE				TELEPHONE EXCHANGE/AUTOVON, PLUS EXTENSION		SIGNATURE	

TO: <i>(Forward to proponent of publication or form) (Include ZIP Code)</i>				FROM: <i>(Activity and location) (Include ZIP Code)</i>			DATE	
PART II- REPAIR PARTS AND SPECIAL TOOL LISTS AND SUPPLY CATALOGS/SUPPLY MANUALS								
PUBLICATION/FORM NUMBER				DATE		TITLE		
PAGE NO.	COLM NO.	LINE NO.	NATIONAL STOCK NUMBER	REFERENCE NO.	FIGURE NO.	ITEM NO.	TOTAL NO. OF MAJOR ITEMS SUPPORTED	RECOMMENDED ACTION
PART III - REMARKS <i>(Any general remarks or recommendations, or suggestions for improvement of publications and blank forms. Additional blank sheets may be used if more space is needed.)</i>								
TYPED NAME, GRADE OR TITLE			TELEPHONE EXCHANGE/AUTOVON, PLUS EXTENSION			SIGNATURE		

RECOMMENDED CHANGES TO PUBLICATIONS AND BLANK FORMS <small>For use of this form, see AR 25-30; the proponent agency is OAASA</small>						Use Part II (reverse) for Repair Parts and Special Tool Lists (RPSTL) and Supply Catalogs/Supply Manuals (SC/SM).	DATE
TO: (Forward to proponent of publication or form) (Include ZIP Code)						FROM: (Activity and location) (Include ZIP Code)	
PART I - ALL PUBLICATIONS (EXCEPT RPSTL AND SC/SM) AND BLANK FORMS							
PUBLICATION/FORM NUMBER						DATE	TITLE
ITEM	PAGE	PARA- GRAPH	LINE	FIGURE NO.	TABLE	RECOMMENDED CHANGES AND REASON	
TYPED NAME, GRADE OR TITLE				TELEPHONE EXCHANGE/AUTOVON, PLUS EXTENSION		SIGNATURE	

TO: <i>(Forward to proponent of publication or form) (Include ZIP Code)</i>				FROM: <i>(Activity and location) (Include ZIP Code)</i>			DATE	
PART II- REPAIR PARTS AND SPECIAL TOOL LISTS AND SUPPLY CATALOGS/SUPPLY MANUALS								
PUBLICATION/FORM NUMBER				DATE		TITLE		
PAGE NO.	COLM NO.	LINE NO.	NATIONAL STOCK NUMBER	REFERENCE NO.	FIGURE NO.	ITEM NO.	TOTAL NO. OF MAJOR ITEMS SUPPORTED	RECOMMENDED ACTION
PART III - REMARKS <i>(Any general remarks or recommendations, or suggestions for improvement of publications and blank forms. Additional blank sheets may be used if more space is needed.)</i>								
TYPED NAME, GRADE OR TITLE			TELEPHONE EXCHANGE/AUTOVON, PLUS EXTENSION			SIGNATURE		

RECOMMENDED CHANGES TO PUBLICATIONS AND BLANK FORMS <small>For use of this form, see AR 25-30; the proponent agency is OAASA</small>						Use Part II (reverse) for Repair Parts and Special Tool Lists (RPSTL) and Supply Catalogs/Supply Manuals (SC/SM).	DATE
TO: (Forward to proponent of publication or form) (Include ZIP Code)						FROM: (Activity and location) (Include ZIP Code)	
PART I - ALL PUBLICATIONS (EXCEPT RPSTL AND SC/SM) AND BLANK FORMS							
PUBLICATION/FORM NUMBER						DATE	TITLE
ITEM	PAGE	PARA-GRAPH	LINE	FIGURE NO.	TABLE	RECOMMENDED CHANGES AND REASON	
TYPED NAME, GRADE OR TITLE				TELEPHONE EXCHANGE/AUTOVON, PLUS EXTENSION		SIGNATURE	

TO: <i>(Forward to proponent of publication or form) (Include ZIP Code)</i>				FROM: <i>(Activity and location) (Include ZIP Code)</i>			DATE	
PART II- REPAIR PARTS AND SPECIAL TOOL LISTS AND SUPPLY CATALOGS/SUPPLY MANUALS								
PUBLICATION/FORM NUMBER				DATE		TITLE		
PAGE NO.	COLM NO.	LINE NO.	NATIONAL STOCK NUMBER	REFERENCE NO.	FIGURE NO.	ITEM NO.	TOTAL NO. OF MAJOR ITEMS SUPPORTED	RECOMMENDED ACTION
PART III - REMARKS <i>(Any general remarks or recommendations, or suggestions for improvement of publications and blank forms. Additional blank sheets may be used if more space is needed.)</i>								
TYPED NAME, GRADE OR TITLE			TELEPHONE EXCHANGE/AUTOVON, PLUS EXTENSION			SIGNATURE		

By Order of the Secretary of the Army:

GEORGE W. CASEY, JR.
General, United States Army
Chief of Staff

Official:



JOYCE E. MORROW
Administrative Assistant to the
Secretary of the Army
1019407

By Order of the Secretary of the Air Force:

Gene

NORTON A. SCHWARTZ
General, USAF
Chief of Staff, USAF

Official:

DONALD J. HOFFMAN
General, USAF
Commander, AFMC

Distribution:

DISTRIBUTION: To be distributed in accordance with the initial distribution number 361115 requirements for TM 9-6115-673-13&P.

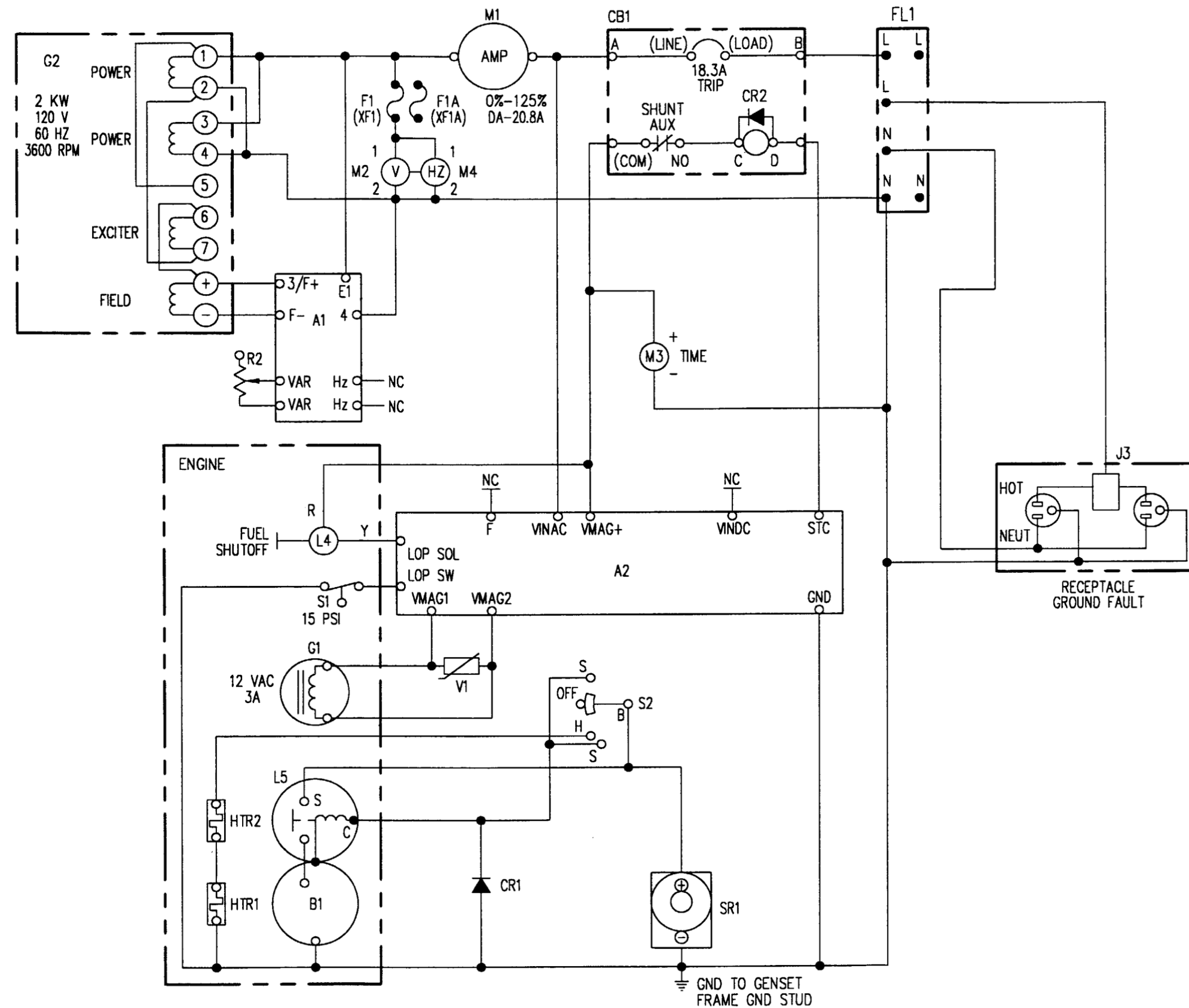

REF DESIGNATOR	DESCRIPTION
A1	VOLTAGE REGULATOR, 120 V, 60 HZ
A2	GENERATOR, CONTROL UNIT
B1	MOTOR, STARTER, PART OF ENGINE
CB1	CIRCUIT BREAKER, SINGLE POLE, SHUNT, AUX
CR1, CR2	DIODE
FL1	EMI FILTER
F1	FUSE
F1A	FUSE, SPARE
G1	DYNAMO, PART OF ENGINE
G2	ALTERNATOR, 120 VAC
HTR1, HTR2	HEATER, ENGINE PREHEAT, PART OF ENGINE
L	TERMINAL, LINE, 120 V, 60 HZ
L4	SOLENOID, LOW OIL PRESSURE
L5	SOLENOID, STARTER MOTOR, PART OF ENGINE
J3	RECEPTACLE, GROUND FAULT
M1	AMMETER
M2	VOLTMETER, AC
M3	METER, TIME TOTALIZING
M4	METER, FREQUENCY
N	TERMINAL, NEUTRAL
R2	POTENTIOMETER, VOLTAGE ADJUST
S1	SWITCH, LOW OIL PRESSURE
S2	SWITCH, ROTARY, FOUR POSITION
SR1	RECEPTACLE, SLAVE
V1	VARISTOR, DISCHARGE
XF1, XF1A	FUSE HOLDER

S2

	START WITH PREHEAT	PREHEAT	OFF	START
B-H	X	X		
B-S	X			X

Figure FO-1. Electrical Schematic, MEP-531A

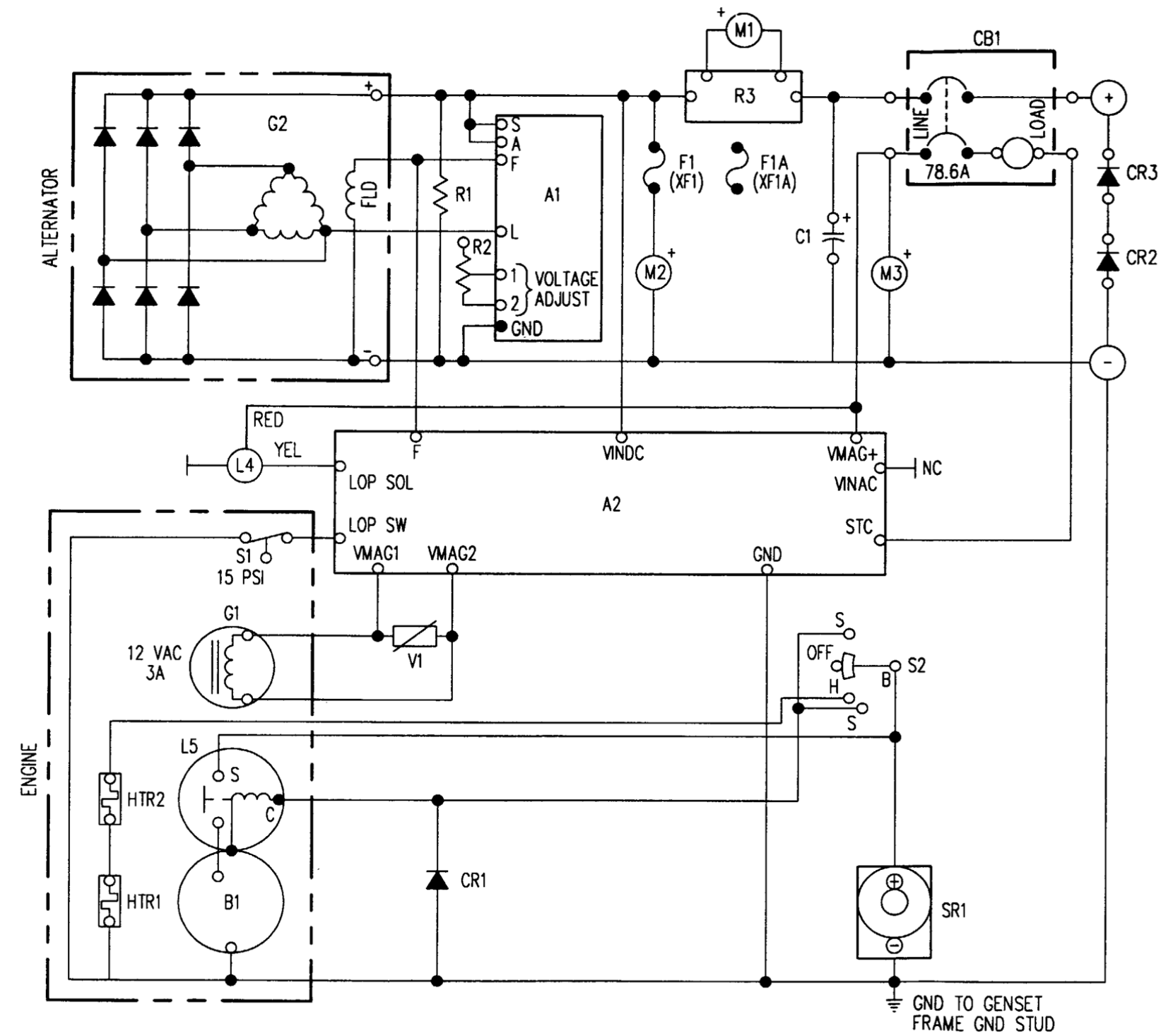

REF DESIGNATOR	DESCRIPTION
A1	REGULATOR, VOLTAGE, 28 VOLT
A2	CONTROL, GENERATOR, 2 KW
B1	MOTOR, STARTER, 24 V DC, PART OF ENGINE
C1	CAPACITOR, 1000 uF 63 VDC
CB1	CIRCUIT BREAKER, 2 POLE
CR1	DIODE
CR2, CR3	DIODE, TRANSIENT SUPPRESSION
F1	FUSE
F1A	FUSE, SPARE
G1	DYNAMO, 12 VAC, 3A, PART OF ENGINE
G2	ALTERNATOR, 2 KW, 28 V DC, 3600 RPM
HTR1, HTR2	HEATER, ENGINE PREHEAT, PART OF ENGINE
-	TERMINAL, NEGATIVE OUTPUT OF GENSET
+	TERMINAL, POSITIVE OUTPUT OF GENSET
L4	SOLENOID, LOW OIL PRESSURE
L5	SOLENOID, STARTER MOTOR, PART OF ENGINE
M1	METER, INDICATION, CURRENT
M2	METER, OUTPUT VOLTAGE
M3	METER, TIME TOTALIZING
R1	RESISTOR, POWER, 20 Ω, 50 W, 1%
R2	POTENTIOMETER, VOLTAGE ADJUSTMENT
R3	RESISTOR, SHUNT 0-89.3A
S1	SWITCH, LOW OIL PRESSURE
S2	SWITCH, START, PREHEAT, SPRING RETURN TO OFF POSITION
SR1	CONNECTOR, PLUG, ELECTRICAL, INTERVEHICLE POWER CABLE
V1	VARISTOR, DISCHARGE
XF1, XF1A	FUSE HOLDER

S2

	START WITH PREHEAT	PREHEAT	OFF	START
B-H	X	X		
B-S	X			X

Figure FO-2. Electrical Schematic, MEP-501A

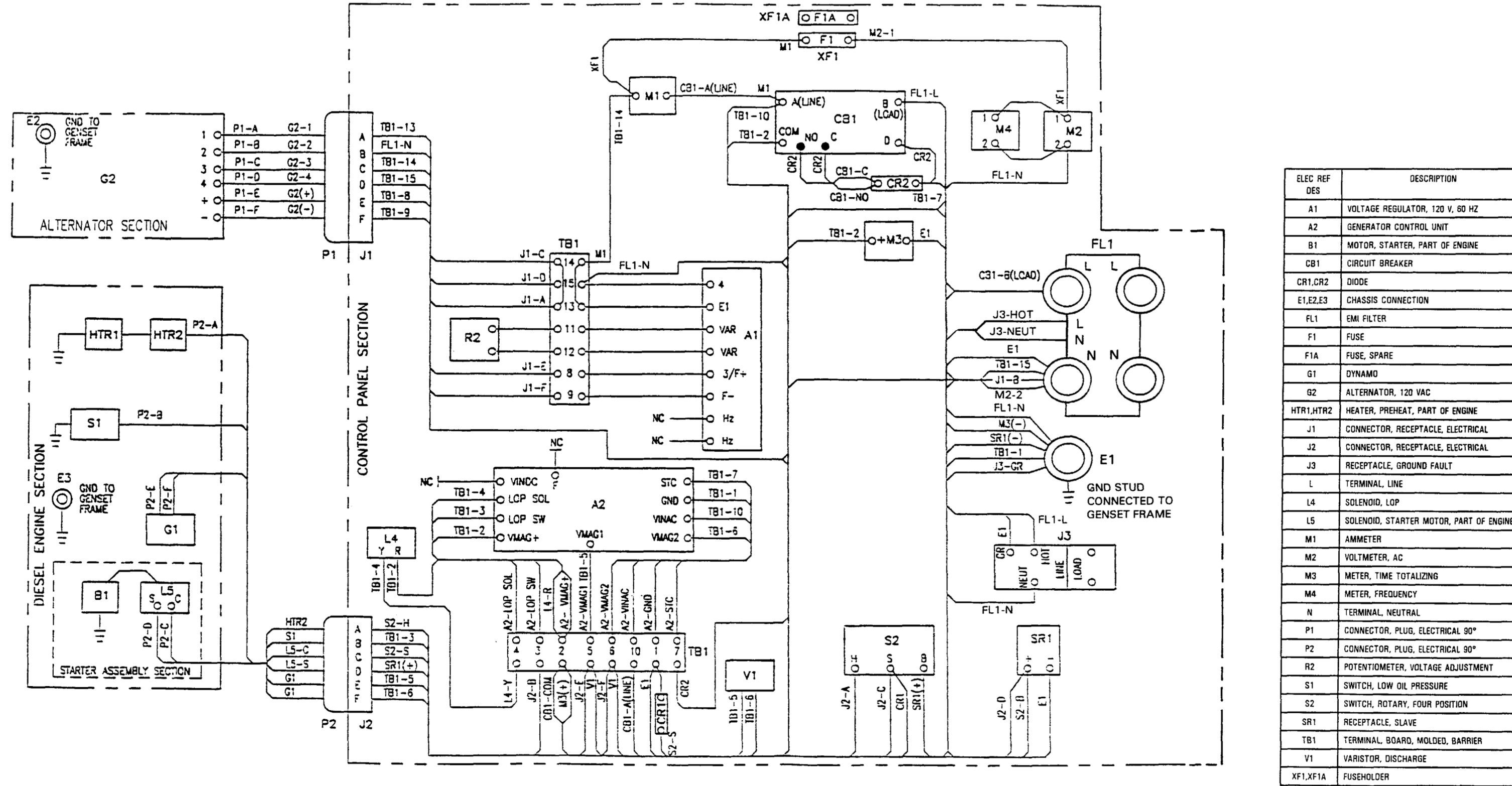

ELEC REF DES	DESCRIPTION
A1	VOLTAGE REGULATOR, 120 V, 60 HZ
A2	GENERATOR CONTROL UNIT
B1	MOTOR, STARTER, PART OF ENGINE
CB1	CIRCUIT BREAKER
CR1,CR2	DIODE
E1,E2,E3	CHASSIS CONNECTION
FL1	EMI FILTER
F1	FUSE
F1A	FUSE, SPARE
G1	DYNAMO
G2	ALTERNATOR, 120 VAC
HTR1,HTR2	HEATER, PREHEAT, PART OF ENGINE
J1	CONNECTOR, RECEPTACLE, ELECTRICAL
J2	CONNECTOR, RECEPTACLE, ELECTRICAL
J3	RECEPTACLE, GROUND FAULT
L	TERMINAL, LINE
L4	SOLENOID, LOP
L5	SOLENOID, STARTER MOTOR, PART OF ENGINE
M1	AMMETER
M2	VOLTMETER, AC
M3	METER, TIME TOTALIZING
M4	METER, FREQUENCY
N	TERMINAL, NEUTRAL
P1	CONNECTOR, PLUG, ELECTRICAL 90°
P2	CONNECTOR, PLUG, ELECTRICAL 90°
R2	POTENTIOMETER, VOLTAGE ADJUSTMENT
S1	SWITCH, LOW OIL PRESSURE
S2	SWITCH, ROTARY, FOUR POSITION
SR1	RECEPTACLE, SLAVE
TB1	TERMINAL BOARD, MOLDED, BARRIER
V1	VARISTOR, DISCHARGE
XF1,XF1A	FUSEHOLDER

Figure FO-3. Wiring Diagram, MEP-531A

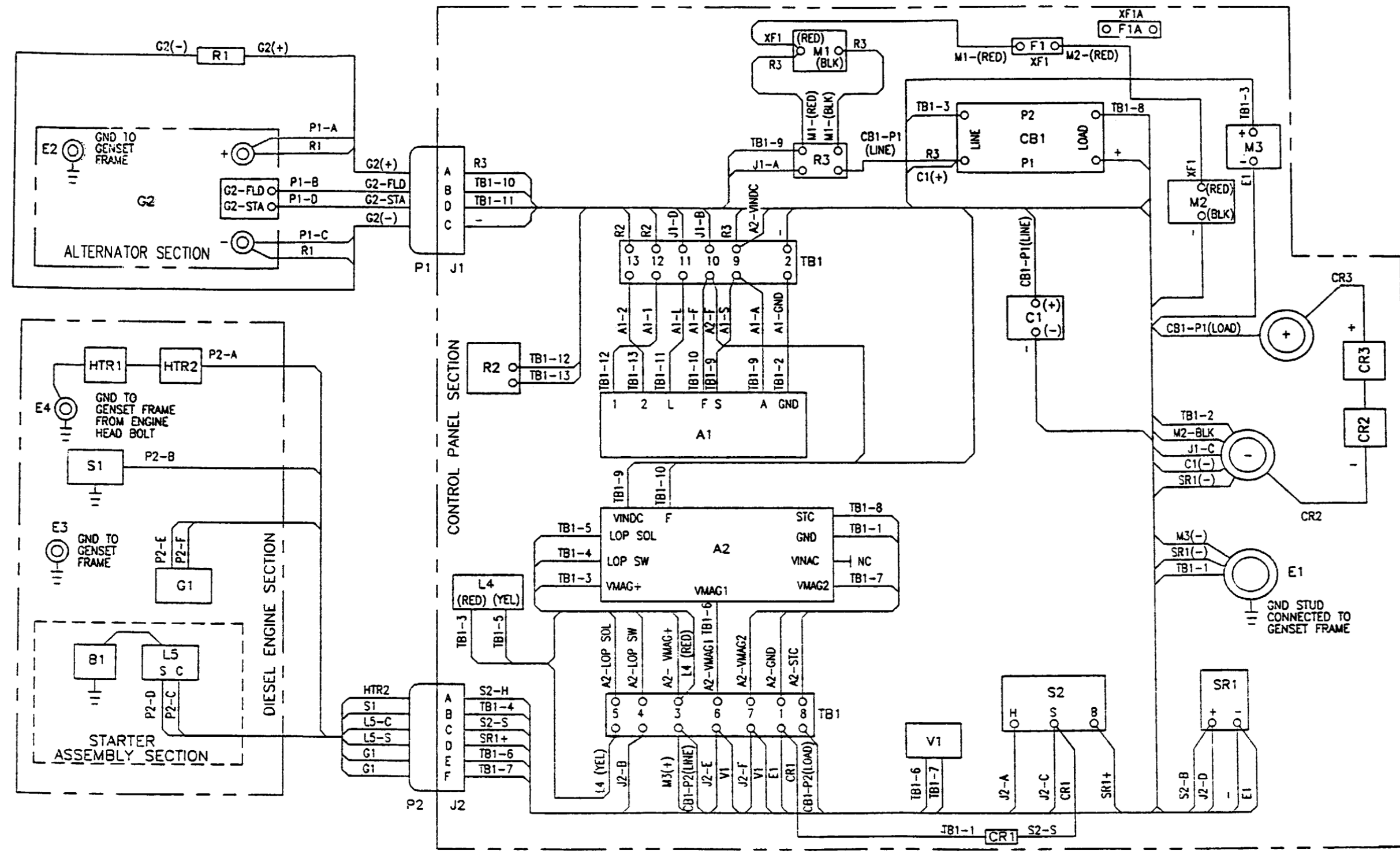

ELEC REF DES	DESCRIPTION
A1	REGULATOR, VOLTAGE, 24 VOLT
A2	CONTROL, GENERATOR
B1	MOTOR, STARTER, 24 VDC, PART OF ENGINE
C1	CAPACITOR, 1000 μF, 63 VDC
CB1	CIRCUIT BREAKER, 2 POLE
CR1	DIODE
CR2, CR3	DIODE, TRANSIENT SUPPRESSION
E1, E2, E3, E4	CHASSIS CONNECTION
F1	FUSE
F1A	FUSE, SPARE
G1	GENERATOR, CHARGING, 12 VAC, 3A, PART OF ENGINE
G2	GENERATOR, 28 VDC
HTR1, HTR2	HEATER, PREHEAT, PART OF ENGINE
-	TERMINAL, NEGATIVE
+	TERMINAL, POSITIVE
L4	SOLENOID, LOP
L5	SOLENOID, STARTER MOTOR, PART OF ENGINE
M1	AMMETER
M2	VOLTMETER, DC
M3	METER, TIME TOTALIZING
R1	RESISTOR, POWER, 20 Ω, 50 W, 1%
R2	POTENTIOMETER, VOLTAGE ADJUSTMENT
R3	RESISTOR, SHUNT, 0-89.3A
S1	SWITCH, LOW OIL PRESSURE
S2	SWITCH, ROTARY, 4 POSITION
SR1	RECEPTACLE, SLAVE, 24 VDC EXTERNAL SUPPLY
TB1	TERMINAL BOARD, MOLDED, BARRIER
V1	VARISTOR, DISCHARGE
P1	CONNECTOR, PLUG, ELECTRICAL, 90°
P2	CONNECTOR, PLUG, ELECTRICAL, 90°
J1	CONNECTOR, RECEPTACLE, ELECTRICAL
J2	CONNECTOR, RECEPTACLE, ELECTRICAL
XF1, XF1A	FUSE HOLDER

Figure FO-4. Wiring Diagram, MEP-501A

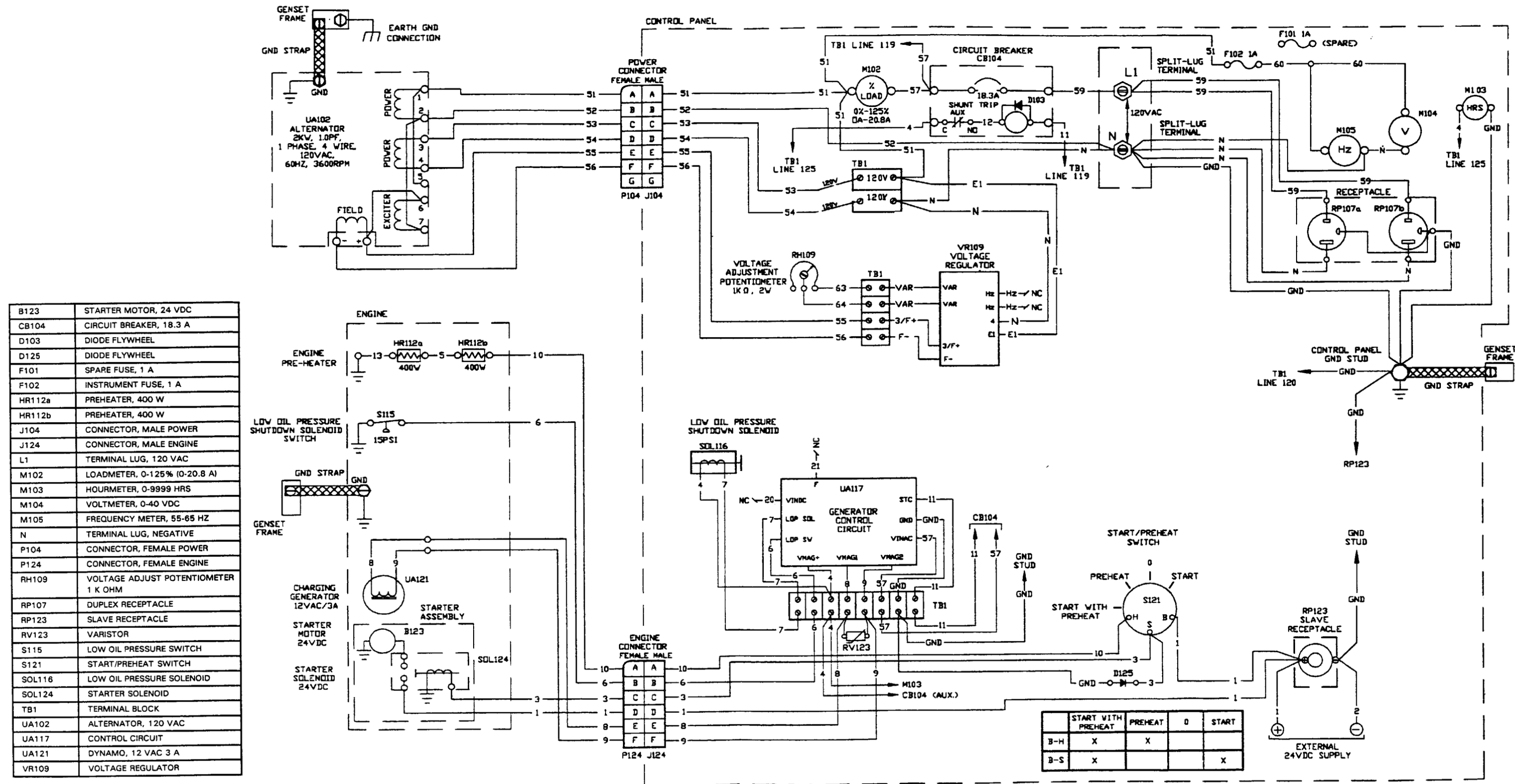

Figure FO-5. Generator Set Schematic, Mechcron 120 VAC

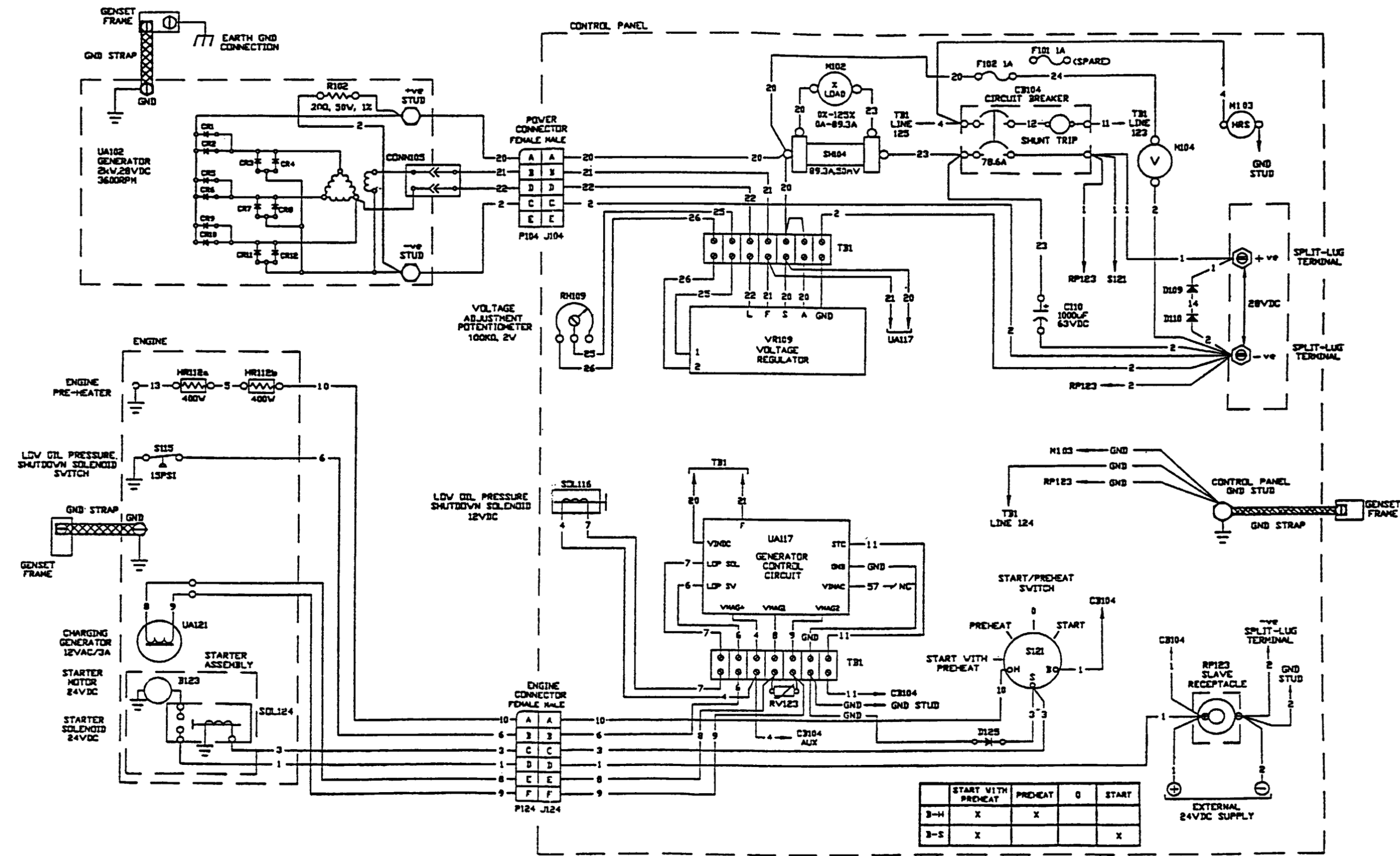

Figure FO-6. Generator Set Schematic, Mechtron 28 VDC

THE METRIC SYSTEM AND EQUIVALENTS

LINEAR MEASURE

1 Centimeter = 10 Millimeter = 0.01 Meters = 0.3937 inches
 1 Meter = 100 Centimeters = 1000 Millimeters = 39.37 inches
 1 kilometer = 1000 Meters = 0.621 Miles

SQUARE MEASURE

1 Sq. Centimeter = 100 Sq. Millimeter = 0.155 Sq. Inches
 1 Sq. Meter = 10,000 Sq. Centimeters = 10.76 Sq. Inches
 1 Sq. Kilometer = 1,000,000 Sq. Meters = 0.386 Sq. Miles

WEIGHTS

1 Gram = 0.001 Kilograms = 1000 Milligrams = 0.035 Ounces
 1 Kilogram = 100 Grams = 2.2 lb. 1 Cu. Meter = 1,000,000
 1 Metric Ton = 1000 Kilograms = 1 Megagram = 1.1 Short Tons

CUBIC MEASURE

1 Cu. Centimeter = 1000 Cu. Millimeters = 0.06 Cu. Inches
 1 Cu. Centimeters = 35.31 Cu. Feet

LIQUID MEASURE

1 Millimeter = 0.001 Liters = 0.0338 Fluid Ounces
 1 Liter = 1000 Millimeters = 32.82 Fluid Ounces

TEMPERATURE

$5/9 (^{\circ}\text{F} - 32) = ^{\circ}\text{C}$
 212° Fahrenheit is equivalent to 100° Celsius
 90° Fahrenheit is equivalent to 32.2° Celsius
 32° Fahrenheit is equivalent to 0° Celsius
 $9/5 ^{\circ}\text{C} + 32 = ^{\circ}\text{F}$

APPROXIMATE CONVERSION FACTORS

TO CHANGE	TO	MULTIPLY BY
Inches.....	Centimeters.....	2.540
Feet.....	Meters.....	0.305
Yards.....	Meters.....	0.914
Miles.....	Kilometers.....	1.609
Square Inches.....	Square Centimeters.....	6.451
Square Feet.....	Square Meters.....	0.093
Square Yards.....	Square Meters.....	0.836
Square Miles.....	Square Kilometers.....	2.590
Acres.....	Square Hectometers.....	0.405
Cubic Feet.....	Cubic Meters.....	0.028
Cubic Yards.....	Cubic Meters.....	0.765
Fluid Ounces.....	Milliliters.....	29.573
Pints.....	Liters.....	0.473
Quarts.....	Liters.....	0.946
Gallons.....	Liters.....	3.785
Ounces.....	Grams.....	28.349
Pounds.....	Kilograms.....	0.454
Short Tons.....	Metric Tons.....	0.907
Pound-Feet.....	Newton-Meters.....	1.356
Pounds per Square Inch.....	Kilo pascals.....	6.895
Miles per Gallon.....	Kilometers per Liter.....	0.425
Miles per Hour.....	Kilometers per Hour.....	1.609

TO CHANGE	TO	DIVIDE BY
Centimeters.....	Inches.....	2.540
Meters.....	Feet.....	0.305
Meters.....	Yards.....	0.914
Kilometers.....	Miles.....	1.609
Square Centimeters.....	Square Inches.....	6.451
Square Meters.....	Square Feet.....	0.093
Square Meters.....	Square Yards.....	0.836
Square Kilometers.....	Square Miles.....	2.590
Square Hectometers.....	Acres.....	0.405
Cubic Meters.....	Cubic Feet.....	0.028
Cubic Meters.....	Cubic Yards.....	0.765
Milliliters.....	Fluid Ounces.....	29.573
Liters.....	Pints.....	0.473
Liters.....	Quarts.....	0.946
Liters-Meters.....	Gallons.....	3.785
Grams.....	Ounces.....	28.349
Kilograms.....	Pounds.....	0.454
Metric Tons.....	Short Tons.....	0.907
Newton-Meters.....	Pound-Feet.....	1.356
Kilo pascals.....	Pounds per Square Inch.....	6.895
Kilometers per Liter.....	Miles per Gallon.....	0.425
Kilometers per Hour.....	Miles per Hour.....	1.609

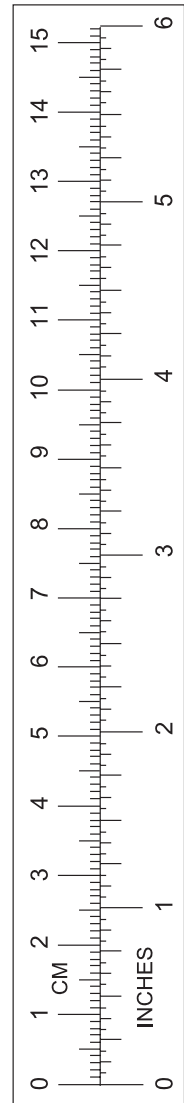

PIN: 077581-000